

SCIENTIFIC SERVICES PROJECT

(USA Track & Field)

HIGH JUMP

#32

(Men)

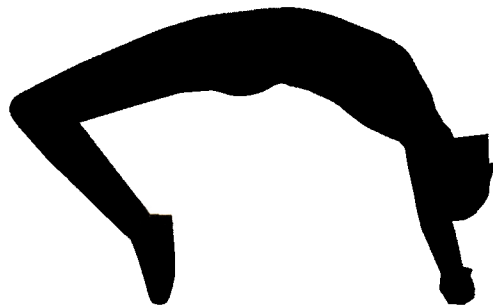

Jesús Dapena and Travis K. Ficklin

Biomechanics Laboratory, Dept. of Kinesiology, Indiana University

IMPORTANT INFORMATION FOR THE COACH:

If one of your high jumpers was studied in our project, we hope you will find the information in this report helpful for the coaching of your athlete.

Although the high jump has been one of the most intensely studied events in track and field, knowledge of it is still imperfect, and there is room for doubts and disagreements. We have tried to give you what we believe are the best possible recommendations, based on the biomechanical information that is presently available, but we do not pretend to have all the answers. We hope you do not feel that we are trying to force our ideas on you, because that is definitely not our intent. Use what you like, and ignore what you don't like. If you find any part of this report useful in any way, we will feel that it has served its purpose.

Here is how we suggest that you use the report:

- Read the main text of the report (“Discussion of high jumping technique, and general analysis of results”). Try to follow the logic that we used to arrive at our conclusions.
- If you feel comfortable with our logic, and it fits with your own ideas, try to implement our recommendations as described in “Specific recommendations for individual athletes”. Throughout the report, keep in mind that “c.m.” stands for “center of mass”, a point that represents the average position of the whole body. This point is also called sometimes the “center of gravity”.
- If you do not agree with our logic, we still hope that you will find our data useful for reaching your own conclusions.

NOTE FOR PREVIOUS READERS OF THESE AND OTHER REPORTS: The masses or weights of the segments that make up the body of an individual athlete are not known exactly, and neither are the moments of inertia nor other important mechanical characteristics of the segments of the human body. Therefore, researchers have to work with *estimates* of those values, and different researchers work with different estimates. The methods used for the calculation of mechanical information (for instance: three-dimensional coordinates of body landmarks, center of mass position, angular momentum) also vary from one researcher to another. Because of this, *it is often not advisable to compare the data from reports produced by different laboratories.*

Even within our own laboratory, some definitions have changed from one report to another. Also, some of the data are calculated with progressively improved methods which give more accurate values. Therefore, the data in this report may not be strictly comparable with data presented in previous reports. However, all values given in the present report were computed using the same method, because any data for jumps from previous years were re-calculated. Therefore, *all the data presented in this report, including data for jumps made in previous years, are compatible with each other.*

Jesús Dapena

Bloomington, November 13, 2007

Department of Kinesiology
HPER 112
Indiana University
Bloomington, IN 47405
U.S.A.

telephone: (812) 855-8407
email: dapena@indiana.edu

TABLE OF CONTENTS

	page
INTRODUCTION	1
GENERAL METHODOLOGY	1
Videotaping and selection of trials	1
Video analysis	1
Sequences	1
Subject characteristics and meet results	1
DISCUSSION OF HIGH JUMPING TECHNIQUE, AND GENERAL ANALYSIS	
OF RESULTS	1
General characteristics of the run-up	2
Approach angles	2
Progression of the run-up	2
Horizontal velocity and height of the c.m. at the end of the run-up	3
Vertical velocity of the c.m. at the start of the takeoff phase	11
Orientation of the takeoff foot, and potential for ankle injuries	12
Trunk lean	12
Arm and lead leg actions	15
Takeoff time	17
Change in horizontal velocity during the takeoff phase	17
Height and vertical velocity of the c.m. at the end of the takeoff phase	17
Height of the bar, peak height of the c.m., and clearance height	19
Takeoff distance	20
Angular momentum	20
Adjustments in the air	28
The twist rotation; problems in its execution	31
Control of airborne movements; computer simulation	33
SPECIFIC RECOMMENDATIONS FOR INDIVIDUAL ATHLETES	35
Dilling	35
Harris	44
Hutchinson	52
Littleton	61
Moffatt	70
Nieto	79
Sellers	88
Shunk	98
Williams	107
REFERENCES	120
ACKNOWLEDGEMENTS	121
APPENDIX 1: TECHNIQUES FOR LOWERING THE CENTER OF MASS IN THE LAST	
STEPS OF THE RUN-UP	122
APPENDIX 2: EXERCISES TO HELP THE LOWERING OF THE CENTER OF MASS IN	
THE LAST STEPS OF THE RUN-UP	127
APPENDIX 3: PRODUCTION OF LATERAL SOMERSAULTING ANGULAR MOMENTUM	129
APPENDIX 4: DRAWING THE PATH OF A HIGH JUMP RUN-UP	131

INTRODUCTION

This report contains a biomechanical analysis of the techniques used by some of the top athletes in the final of the men's high jump event at the 2007 USATF Championships. Data from analyses made in previous years are also shown for some of these athletes.

The report evaluates the advantages and disadvantages of the techniques used by the analyzed athletes, and suggests how to correct some of the technique problems found. The rationale used for the technique evaluations stems from a comprehensive interpretation of the Fosbury-flop style of high jumping that is based on the research of Dyatchkov (1968) and Ozolin (1973), on basic research carried out by the first author of this report (Dapena, 1980a, 1980b, 1987a, 1995a, 1995b; Dapena *et al.*, 1988, 1990, 1997a), and on the experience accumulated through the analysis of American and other high jumpers at Indiana University since 1982 (Dapena, 1987b, 1987c; Dapena *et al.*, 1982, 1983a, 1983b, 1986a, 1986b, 1986c, 1991, 1993a, 1993b, 1993c, 1994a, 1994b, 1995a, 1995b, 1997b, 1997c, 1998a, 1998b, 1999a, 1999b, 2001a, 2001b, 2002a, 2002b, 2003a, 2003b, 2004a, 2004b, 2006a, 2006b, 2007) in the course of service work sponsored by the United States Olympic Committee, USA Track & Field and/or the International Olympic Committee.

GENERAL METHODOLOGY

Videotaping and selection of trials

The jumps were videotaped simultaneously with two high definition video cameras shooting at 50 images per second. It was not possible to record all the jumps in the meet. However, it was possible to find for all the athletes presented in this report at least one trial that was representative of the best jumps of the athlete during the competition. (The best jump of an athlete is not necessarily a successful clearance.)

A number was assigned to each trial. This number simply indicated the order of appearance of that jump in our videos, and it is used here for identification purposes.

Video analysis

The locations of 21 body landmarks were measured ("digitized") in the images obtained by the two cameras. Computer programs were then used to calculate the three-dimensional (3D) coordinates of the body landmarks from the final part of the run-up through the takeoff phase and the bar clearance. Another program used these 3D coordinates to calculate the location of the center of mass (c.m.) (also called the center of gravity, c.g.), speed of the

run-up, step lengths, and other information.

Sequences

Computer graphics were used to produce several motion sequences for each jump. They are inserted in this report immediately after the individual analysis of each athlete. There are three pages of sequences for each trial.

The first page is labeled "Run-up", and it shows a double sequence of the end of the run-up and the takeoff phase. The top of the page shows a side view; the bottom of the page shows a back view. The back view is what would be seen by a hypothetical observer following the athlete along the curved path of the run-up; the side view is what would be seen by an observer standing at the center of the run-up curve. The numbers at the bottom of the page indicate time, in seconds. To facilitate the comparison of one jump with another, the value $t = 10.00$ seconds was arbitrarily assigned in all trials to the instant when the takeoff foot first made contact with the ground to start the takeoff phase.

The next page of computer plots (labeled "Takeoff Phase") shows side and back views of a detailed sequence of the takeoff phase. (The sequence usually extends somewhat beyond the loss of contact of the takeoff foot with the ground.)

The third page (labeled "Bar Clearance") shows a double sequence of the bar clearance. The top of the page shows the view along the bar; the bottom of the page shows the view perpendicular to the plane of the bar and the standards.

Subject characteristics and meet results

Table 1 shows general information on the analyzed athletes, and their results in the competitions. All the jumpers used the Fosbury-flop style.

DISCUSSION OF HIGH JUMPING TECHNIQUE, AND GENERAL ANALYSIS OF RESULTS

A high jump can be divided into three parts: the run-up phase, the takeoff phase, and the flight or bar clearance phase. The purpose of the run-up is to set the appropriate conditions for the beginning of the takeoff phase. During the takeoff phase, the athlete exerts forces that determine the maximum height that the c.m. will reach after leaving the ground and the angular momentum (also called "rotary momentum") that the body will have during the bar clearance. The only active movements that can be made after leaving the ground are internal compensatory movements (for instance, one part of the body can be

Table 1

General information on the analyzed jumpers, and meet results.

Athlete	Standing height (m)	Weight (Kg)	Personal best mark (*) (m)	Best heights cleared at meets (**) (m)
Jim DILLING	1.95	86	2.30	2.27 (U07)
Tora HARRIS	1.91	84	2.33	2.24 (U01); 2.24 (U02); 2.22 (U03); 2.27 (T04); 2.33 (U06); 2.21 (U07)
Eugene HUTCHINSON	1.89	76	2.26	2.21 (U07)
Will LITTLETON	1.87	77	2.28	2.18 (U07)
Keith MOFFATT	1.99	80	2.30	2.27 (T04); 2.30 (U06); 2.24 (U07)
Jamie NIETO	1.94	84	2.34	2.25 (U99); 2.21 (U01); 2.24 (U02); 2.30 (U03); 2.33 (T04); 2.19 (U06); 2.24 (U07)
Scott SELLERS	1.88	75	2.33	2.19 (U06); 2.18 (U07)
Adam SHUNK	1.83	75	2.30	2.24 (T04); 2.24 (U07)
Jesse WILLIAMS	1.84	73	2.33	2.24 (T04); 2.24 (U07)

(*) by the end of the last meet in which the jumper was analyzed

(**) U99 = 1999 USATF Ch.; U01 = 2001 USATF Ch.; U02 = 2002 USATF Ch.; U03 = 2003 USATF Ch.; T04 = 2004 U.S. Olympic Trials; U06 = 2006 USATF Ch.; U07 = 2007 USATF Ch.

lifted by lowering another part; one part of the body can be made to rotate faster by making another part slow down its rotation).

The run-up serves as a preparation for the takeoff phase, the most important part of the jump. The actions of the athlete during the bar clearance are less important: Most of the problems found in the bar clearance actually originate in the run-up or takeoff phases.

General characteristics of the run-up

The typical length of the run-up for experienced high jumpers is about 10 steps. In the Fosbury-flop technique, the first part of the run-up usually follows a straight line perpendicular to the plane of the standards, and the last four or five steps follow a curve (Figure 1). One of the main purposes of the curve is to make the jumper lean away from the bar at the start of the takeoff phase. The faster the run or the tighter the curve, the greater the lean toward the center of the curve. (For more details on the shape of the run-up, see Appendix 4.)

Approach angles

Figure 2 shows an overhead view of the last two

steps of the run-up, the takeoff phase and the airborne phase. Notice that the c.m. (c.g.) path is initially to the left of the footprints. This is because the athlete

is leaning toward the left during the curve. The c.m. path then converges with the footprints, and the c.m. is pretty much directly over the takeoff foot at the end of the takeoff.

Figure 2 also shows angles t_1 , p_2 , p_1 and p_0 : t_1 is the angle between the bar and the line joining the last two footprints; p_2 and p_1 are the angles between the bar and the path of the c.m. in the airborne phases of the last two steps; p_0 is the angle between the bar and the path of the c.m. during the airborne phase that follows the takeoff. The angles are smaller in athletes who move more parallel to the bar. The values of these angles are shown in Table 2.

Progression of the run-up

To start the run-up, the athlete can either take a few walking steps and then start running, or make a standing start. In the early part of the run-up the athlete needs to follow a gradual progression in which each step is a little bit longer and faster than the previous one. After a few steps, the high jumper

Figure 1

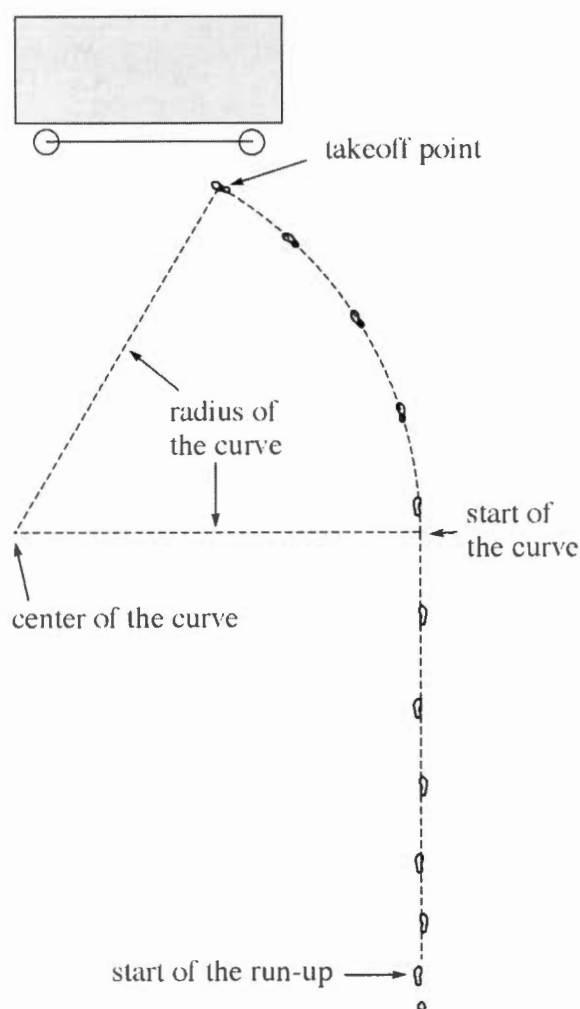

will be running pretty fast, with long, relaxed steps, very similar to those of a 400-meter or 800-meter runner. In the last two or three steps of the run-up the athlete should gradually lower the hips. It must be stressed here that this lowering of the hips has to be achieved without incurring a significant loss of running speed.

Horizontal velocity and height of the c.m. at the end of the run-up

The takeoff phase is defined as the period of time between the instant when the takeoff foot first touches the ground (touchdown) and the instant when it loses contact with the ground (takeoff). During the takeoff phase, the takeoff leg pushes down on the ground. In reaction, the ground pushes upward on the body through the takeoff leg with an equal and

Figure 2

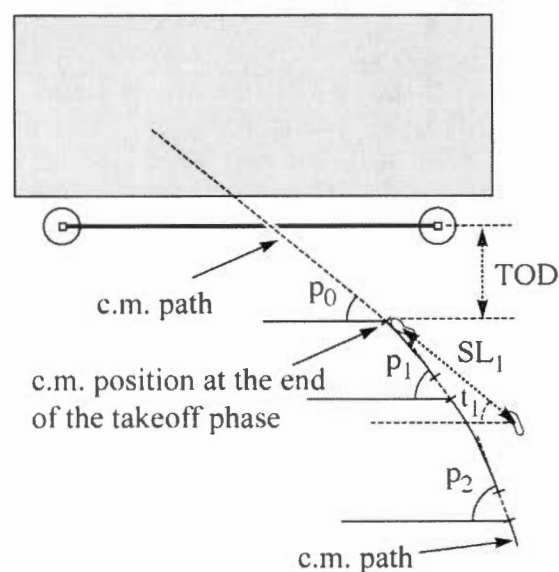

opposite force. The upward force exerted by the ground on the athlete is much larger than body weight, and it changes the vertical velocity of the c.m. from a value that is initially close to zero to a large upward vertical velocity. The vertical velocity of the athlete at the end of the takeoff phase determines the peak height that the c.m. will reach after the athlete leaves the ground, and is therefore of great importance for the result of the jump.

To maximize the vertical velocity at the end of the takeoff phase, the product of the vertical force exerted by the athlete on the ground and the time during which this force is exerted should be as large as possible. This can be achieved by making the vertical force as large as possible and the vertical range of motion through which the c.m. travels during the takeoff phase as long as possible.

A fast approach run can help the athlete to exert a larger vertical force on the ground. This can be achieved in the following way: When the takeoff leg is planted ahead of the body at the end of the run-up, the knee extensor muscles (quadriceps) resist against the flexion of the leg, but the leg is forced to flex anyway, because of the forward momentum of the jumper. In this process the takeoff leg's knee extensor muscles are stretched. It is believed that this stretching produces a stimulation of the muscles, which in turn allows the foot of the takeoff leg to press harder against the ground. In this way, a fast run-up helps to increase the vertical force exerted during the takeoff phase. (For a more extended

Table 2

Direction of the footprints of the last step (t_1), direction of the path of the c.m. in the last two steps (p_2 and p_1) and after takeoff (p_0), direction of the longitudinal axis of the foot with respect to the bar (e_1), with respect to the final direction of the run-up (e_2) and with respect to the horizontal force made on the ground during the takeoff phase (e_3), length of the last step (SL_1 , expressed in meters and also as a percent of the standing height of the corresponding athlete), and takeoff distance (TOD). Note: Some of the values in this table may not fit perfectly with each other, because of rounding off.

Athlete	Trial and meet (*)	t_1	p_2	p_1	p_0	e_1	e_2	e_3	SL_1		TOD
		(°)	(°)	(°)	(°)	(°)	(°)	(°)	(m)	(%)	
Dilling	97 U07	37	55	47	43	19	28	33	2.05	105	1.23
Harris	21 U01	34	51	44	36	4	39	46	2.03	106	1.09
	17 U02	27	50	39	40	6	33	33	1.99	104	1.09
	11 U03	27	49	41	39	11	30	32	1.85	97	1.14
	30 T04	31	52	47	40	13	34	42	1.90	100	1.08
	38 U06	31	55	46	42	15	30	35	1.94	101	1.50
61 U07	30	53	43	39	21	22	26	1.98	104	1.25	
Hutchinson	72 U07	37	55	47	45	36	11	14	2.12	112	0.95
Littleton	48 U07	34	56	45	41	16	29	34	1.94	104	1.17
Moffatt	33 T04	28	52	39	35	12	26	31	2.17	109	0.98
	40 U06	27	57	41	42	20	21	21	2.18	109	0.92
	84 U07	33	57	45	40	24	22	28	2.09	105	1.03
Nieto	17 U99	34	61	47	40	3	44	51	2.02	104	0.96
	36 U01	32	59	46	42	6	40	45	1.91	98	1.13
	13 U02	28	59	43	41	15	28	30	1.90	98	1.07
	37 U03	26	55	43	38	7	35	40	1.96	101	1.04
	62 T04	24	53	39	39	9	31	32	2.02	104	1.01
	24 U06	31	60	46	44	2	44	46	2.05	106	1.48
99 U07	32	58	46	38	4	42	52	1.97	102	1.05	
Sellers	03 U06	43	56	50	46	38	12	17	2.14	114	1.25
	42 U07	45	56	52	53	34	17	16	2.09	111	1.40
Shunk	28 T04	29	52	42	35	8	34	40	1.94	106	0.79
	95 U07	29	53	41	37	2	39	43	1.77	97	1.00
Williams	16 T04	19	48	37	37	2	35	35	1.81	99	0.94
	82 U07	33	59	48	43	0	48	54	1.76	96	1.43

(*) U99 = 1999 USATF Ch.; U01 = 2001 USATF Ch.; U02 = 2002 USATF Ch.; U03 = 2003 USATF Ch.; T04 = 2004 U.S. Olympic Trials; U06 = 2006 USATF Ch.; U07 = 2007 USATF Ch.

discussion of the mechanisms that may be involved in the high jump takeoff, see Dapena and Chung, 1988.) Table 3 shows the values of v_{H2} , the horizontal velocity of the athlete in the next-to-last step of the run-up, and of v_{H1} , the horizontal velocity of the athlete in the last step of the run-up, just before the takeoff foot is planted on the ground. The value of v_{H1} is the important one.

To maximize the vertical range of motion through which force is exerted on the body during the takeoff phase, it is necessary for the center of mass to be in a low position at the start of the takeoff phase

and in a high position at the end of the takeoff. Most high jumpers have no trouble achieving a reasonably high position at the end of the takeoff; the greatest difficulty lies in the establishment of a low position at the start of the takeoff phase. There are two ways to produce a low position of the c.m. at the start of the takeoff phase: (a) to run with bent legs in the last couple of steps of the run-up; and (b) to run on a curve, which makes the athlete lean toward the center of the curve, and thus produces a further lowering of the c.m. The c.m.-lowering effects of the two methods are additive, and high jumpers normally

Table 3

Height of the c.m. at the start of the takeoff phase (h_{TD} , expressed in meters and also as a percent of the standing height of each athlete), horizontal velocity in the last two steps of the run-up (v_{H2} and v_{H1}), horizontal velocity after takeoff (v_{HTO}), change in horizontal velocity during the takeoff phase (Δv_H), vertical velocity at the start of the takeoff phase (v_{ZTD}), and vertical velocity at the end of the takeoff phase (v_{ZTO}). Note: Some of the values in this table may not fit perfectly with each other, because of rounding off.

Athlete	Trial and meet (*)	h_{TD}		v_{H2} (m/s)	v_{H1} (m/s)	v_{HTO} (m/s)	Δv_H (m/s)	v_{ZTD} (m/s)	v_{ZTO} (m/s)
		(m)	(%)						
Dilling	97 U07	0.92	47.5	7.9	7.8	4.2	-3.6	-0.6	4.40
Harris	21 U01	0.84	44.0	8.1	8.0	3.9	-4.1	-0.7	4.40
	17 U02	0.86	45.0	7.7	7.8	3.9	-3.9	-0.6	4.40
	11 U03	0.88	46.0	8.0	7.7	4.1	-3.6	-0.3	4.40
	30 T04	0.88	46.0	8.1	7.7	4.0	-3.7	-0.4	4.30
	38 U06	0.86	45.0	8.2	8.0	4.5	-3.6	-0.4	4.50
	61 U07	0.85	44.5	8.3	8.0	4.2	-3.8	-0.3	4.30
Hutchinson	72 U07	0.82	43.5	7.3	7.2	3.5	-3.7	-0.5	4.30
Littleton	48 U07	0.86	46.0	7.8	7.9	4.6	-3.3	-0.3	4.15
Moffatt	33 T04	0.97	48.5	7.9	7.7	4.2	-3.5	-0.5	4.30
	40 U06	0.94	47.0	7.2	7.3	3.6	-3.7	-0.4	4.45
	84 U07	0.96	48.5	6.9	7.2	3.8	-3.3	-0.3	4.30
Nieto	17 U99	0.91	47.0	7.2	7.0	3.6	-3.4	-0.3	4.30
	36 U01	0.88	45.5	7.7	7.1	3.7	-3.4	-0.3	4.30
	13 U02	0.88	45.5	7.6	7.2	3.6	-3.6	-0.2	4.30
	37 U03	0.89	46.0	7.4	7.3	3.8	-3.5	-0.3	4.40
	62 T04	0.92	47.5	7.2	6.9	3.4	-3.5	-0.5	4.40
	24 U06	0.90	46.5	7.6	7.4	4.0	-3.4	-0.2	4.25
	99 U07	0.91	46.5	7.1	7.3	4.0	-3.4	-0.3	4.30
Sellers	03 U06	0.89	47.5	7.8	8.0	4.5	-3.4	-0.5	4.30
	42 U07	0.90	48.0	7.5	7.7	4.3	-3.4	-0.6	4.25
Shunk	28 T04	0.81	44.5	7.8	7.0	3.5	-3.5	-0.2	4.35
	95 U07	0.84	46.0	7.7	7.1	3.9	-3.2	-0.1	4.40
Williams	16 T04	0.88	47.5	7.4	7.3	3.8	-3.4	-0.2	4.40
	82 U07	0.88	48.0	7.8	7.7	4.3	-3.4	-0.3	4.50

(*) U99 = 1999 USATF Ch.; U01 = 2001 USATF Ch.; U02 = 2002 USATF Ch.; U03 = 2003 USATF Ch.; T04 = 2004 U.S. Olympic Trials; U06 = 2006 USATF Ch.; U07 = 2007 USATF Ch.

lower the c.m. through the combination of both methods.

Running with bent legs requires the body to be supported by a deeply flexed non-takeoff leg during the next-to-last step of the run-up, and this requires a very strong non-takeoff leg. Also, it is difficult to learn the appropriate neuromuscular patterns that will allow the athlete to pass over the deeply flexed non-takeoff leg without losing speed. Still, it is possible to learn how to run fast with bent legs. It requires a considerable amount of effort and training, but athletes should be strongly encouraged to put in the

necessary work to achieve this, since the results will be highly rewarding. Appendix 2 describes some exercises that can help high jumpers to run with bent legs in the last steps of the run-up without losing speed, and to produce a good position for the body at the start of the takeoff phase.

By running on a curve, the athlete can reduce the amount of leg flexion needed to attain any given amount of c.m. lowering. Therefore, the curved run-up makes it easier to maintain a fast running speed while lowering the c.m. Unfortunately, the amount of c.m. lowering that can be produced exclusively

through curve-induced leaning is rather limited. Therefore, high jumpers normally need to combine bent-legs running with the use of a curved run-up to produce the necessary amount of lowering of the c.m.

Table 3 shows the value of h_{TD} , the height of the c.m. at the instant when the takeoff foot is planted on the ground to start the takeoff phase. It is the combined result of running with bent legs and leaning toward the center of the curve. It is expressed in meters, but also as a percent of each athlete's standing height. The percent values are more meaningful for the comparison of one athlete with another.

Let's say that an athlete has learned how to run fast and low. A new problem could occur: The athlete could actually be too fast and too low. If the takeoff leg is not strong enough, it will be forced to flex excessively during the takeoff phase, and then it may not be able to make a forceful extension in the final part of the takeoff phase. In other words, the takeoff leg may buckle (collapse) under the stress, and the result will be a very low jump or an aborted jump. Therefore, it is important to find the optimum combination of run-up speed and c.m. height. We will now see how this can be done.

Figure 3 shows a plot of h_{TD} versus v_{HI} . (At this time, please ignore the diagonal lines; we will deal with them later on.) Each point on the graph represents one jump by one athlete. A different symbol has been assigned to each athlete. This symbol will be used for that athlete in all graphs of this report. Points in the left part of the graph represent jumps with a slow speed at the end of the run-up; points in the right part of the graph represent jumps with a fast speed at the end of the run-up. Points in the upper part of the graph represent jumps with a high c.m. at the end of the run-up; points in the lower part of the graph represent jumps with a low c.m. at the end of the run-up. This kind of graph permits to visualize simultaneously how fast and how high an athlete was at the end of the run-up. For instance, a point in the upper right part of the graph would indicate a jump with a fast run-up but a high c.m. position at the end of the run-up.

(At this point, it is important to consider the accuracy of these values. All measurements have some degree of error, and depending on what is being measured, the error may be larger or smaller. The errors in the v_{HI} values are small, typically less than 0.1 m/s; the errors in the h_{TD} values can be of greater significance. It is easy for the value of h_{TD} to be half a percent point off for any jump, and occasionally it could be off by as much as one whole percent point. Therefore, if two jumpers had, for instance, h_{TD} values of 46.5% and 49.0%, respectively, we could be pretty sure that the first jumper really was lower

than the second one. However, if the two values of h_{TD} were, for instance, 46.5% and 48.0% it would not be possible to be completely sure which of the jumpers was lower, because the 46.5% could be really 47.5%, and the 48.0% could be really 47.0%.)

Let's consider what would happen if all the athletes shown in Figure 3 had similar dynamic strength in the takeoff leg. In such case, the athletes in the upper left part of the graph would be far from their limit for buckling, the athletes in the lower right part of the graph would be closest to buckling, and the athletes in the center, lower left and upper right parts of the graph would be somewhere in between with respect to the risk of buckling. Therefore, if all the athletes shown in Figure 3 had similar dynamic strength, we would recommend the athletes in the upper left part of the graph to learn how to run faster and lower (see Appendix 2), and then experiment with jumps using run-ups that are faster and/or lower than their original ones. The athletes in the center, lower left and upper right parts of the graph would also be advised to experiment with faster and lower run-ups, possibly emphasizing "faster" for the jumpers in the lower left part of the graph, and "lower" for the jumpers in the upper right part of the graph. The athletes in the lower right part of the graph would be cautioned against the use of much faster and/or lower run-ups than their present ones, because these athletes would already be closer to buckling than the others.

The procedure just described would make sense if all the jumpers shown in Figure 3 had similar dynamic strength in the takeoff leg. However, this is not a good assumption: The takeoff legs of different high jumpers will have different amounts of dynamic strength, and more powerful athletes will be able to handle faster and lower run-ups without buckling. Therefore, it is possible that an athlete in the upper left part of the graph might be weak, and thus already close to buckling, while an athlete farther down and to the right in the graph might be more powerful, and actually farther from buckling. The optimum combination of run-up speed and c.m. height will be different for different high jumpers, and we will need to know a high jumper's dynamic strength before we can predict how fast and how low that high jumper should be at the end of the run-up.

It is not easy to measure the dynamic strength of a high jumper's takeoff leg. The personal record of an athlete in a squat lift or in a vertical jump-and-reach test are not good indicators of the dynamic strength of the takeoff leg. This is because these tests do not duplicate closely enough the conditions of the high jump takeoff. The best indicator that we have found of the takeoff leg's dynamic strength is the capability of the high jumper to generate lift in an

Figure 3

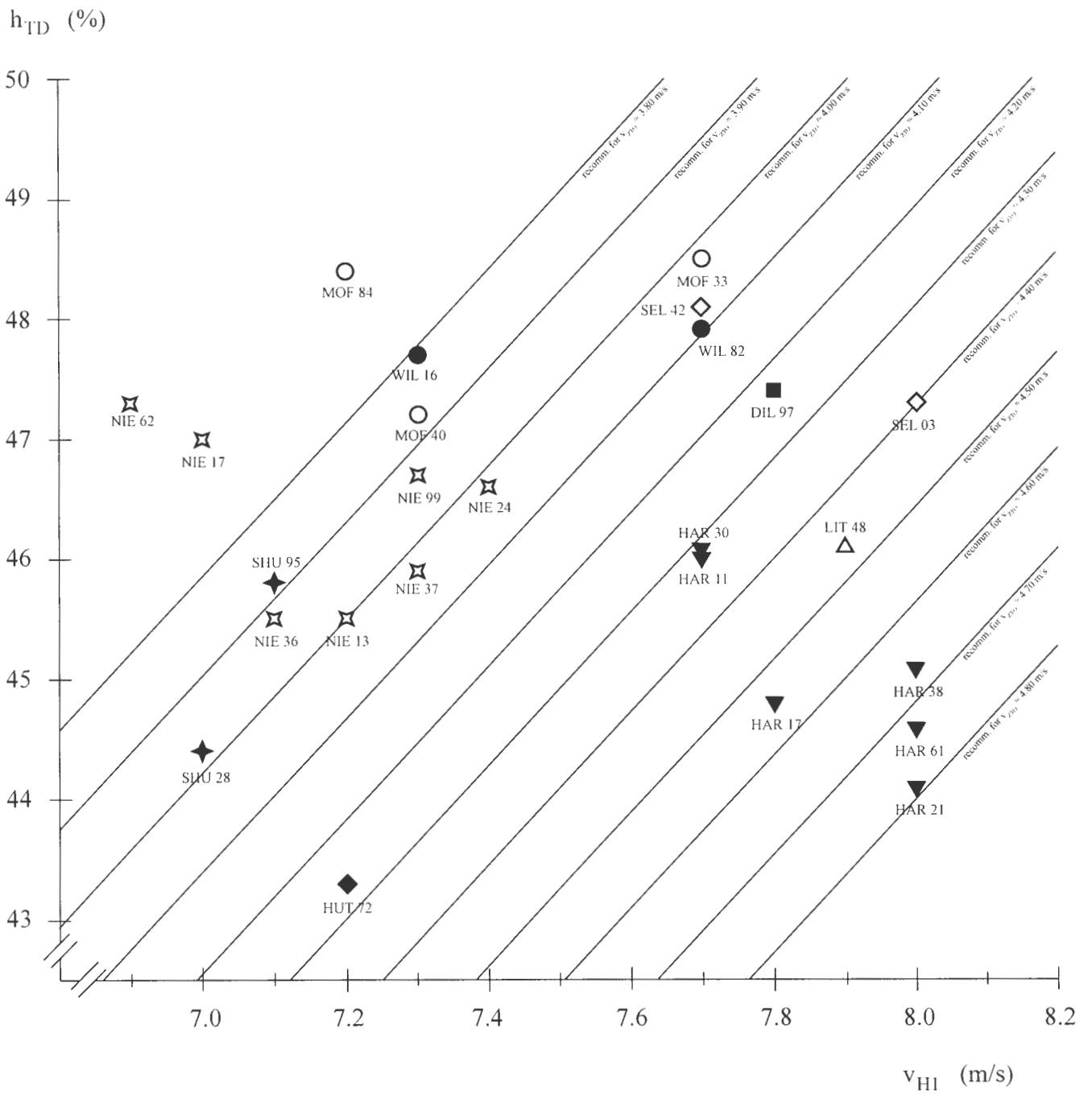

actual high jump. Therefore, we use the vertical velocity achieved by the high jumper at the end of the takeoff phase (v_{ZTO} —see below) to indicate the athlete's dynamic strength or “takeoff power”.

To help us in our prediction of the optimum horizontal speed at the end of the run-up from the dynamic strength of the takeoff leg, we made use of statistical information accumulated through film analyses of male and female high jumpers in the course of Scientific Support Services work sponsored at Indiana University by the United States Olympic Committee and by USA Track & Field (formerly The Athletics Congress) in the period 1982-1987. The athletes involved in these studies were all elite high jumpers filmed at the finals of national and international level competitions (USATF and NCAA Championships; U.S. Olympic Trials; World Indoor Championships).

Each of the small open circles in Figure 4 represents one jump by one of the athletes in our original statistical sample. The other symbols represent the athletes analyzed for the present report. The horizontal axis of the graph shows vertical velocity at takeoff (v_{ZTO}): The most powerful high jumpers are the ones who are able to generate more lift, and they are to the right in the graph; the weaker jumpers are to the left. The vertical axis shows the final speed of the run-up (v_{HI}). The diagonal “regression” line shows the trend of the statistical data. The graph agrees with our expectations: The more powerful jumpers, those able to get more lift (larger v_{ZTO}), can also handle faster run-ups (larger v_{HI}) without buckling.

So, what is the optimum run-up speed for a given high jumper? It seems safe to assume that most high jumpers will not use regularly a run-up that is so fast that the takeoff leg will buckle. This is because it takes intense concentration and effort for a high jumper to use a fast run-up, and if the athlete feels that the leg has buckled in one jump, an easier (slower) run-up will be used in further jumps. Since buckling (or at least partial buckling) will begin to occur at run-up speeds immediately faster than the optimum, this means that few high jumpers should be expected to use regularly run-ups that are faster than their optimum. On the other hand, we should expect a larger number of high jumpers to use run-up speeds that are slower than their optimum. This is because a fair number of high jumpers have not learned to use a fast enough run-up. Therefore, the diagonal regression line which marks the average trend in the graph represents speeds that are slower than the optimum. In sum, although the precise value of the optimum run-up speed is not known for any given value of v_{ZTO} , we know that it will be faster than the value indicated by the diagonal regression line, and

that athletes near the regression line or below it were running too slowly at the end of the run-up.

A similar rationale can be followed with the graph of h_{TD} vs. v_{ZTO} , shown in Figure 5. Each of the small open circles in Figure 5 represents one jump by one of the athletes in our statistical sample. The other symbols represent the athletes analyzed for the present report. The horizontal axis of the graph again shows vertical velocity at takeoff (v_{ZTO}): The most powerful high jumpers are the ones who are able to generate more lift, and they are to the right in the graph; the weaker jumpers are to the left. The vertical axis shows the height of the c.m. at the start of the takeoff phase (h_{TD}), expressed as a percent of the athlete's standing height. The diagonal regression line shows the trend of the statistical data. Although the data are more “noisy” than in the previous graph (i.e., there is a wider “cloud” around the regression line), the graph in Figure 5 also agrees with our general expectations: The more powerful jumpers (larger v_{ZTO} values) are able to be lower at the end of the run-up (smaller h_{TD} values) without buckling during the takeoff phase. In Figure 5, jumpers on the regression line or above it will have bad techniques in this regard, and the optimum will be somewhere below the regression line.

When Figures 4 and 5 are used as diagnostic tools, it is necessary to take into consideration the information from both graphs. For instance, if a given athlete is pretty much on the regression lines of Figures 4 and 5, or below the regression line in Figure 4 and above the regression line in Figure 5, we should presume that this athlete is not near the buckling point. Therefore the athlete should be advised to increase the run-up speed and/or to run with lower hips at the end of the run-up. However, if an athlete is slightly below the regression line in Figure 4, but markedly below it in Figure 5, the case is different. Since the c.m. was very low during the run-up, maybe the athlete was close to the buckling point, even though the run-up speed was not very fast. In this case, it would not be appropriate to advise an increase in run-up speed, even if the athlete's run-up speed was somewhat slow in comparison to what we would expect on the average.

By now, it should be clear to the reader that the intensity of the demands put on the takeoff leg during the takeoff phase depends mainly on the combination of final run-up speed and c.m. height at the end of the run-up. Therefore, the advice given to an individual athlete needs to take into account both of these factors simultaneously. This is where the diagonal lines in Figure 3 come into play. Each diagonal line indicates combinations of run-up speed and c.m. height that are equally demanding for the takeoff leg. Diagonal lines further down and toward the right on

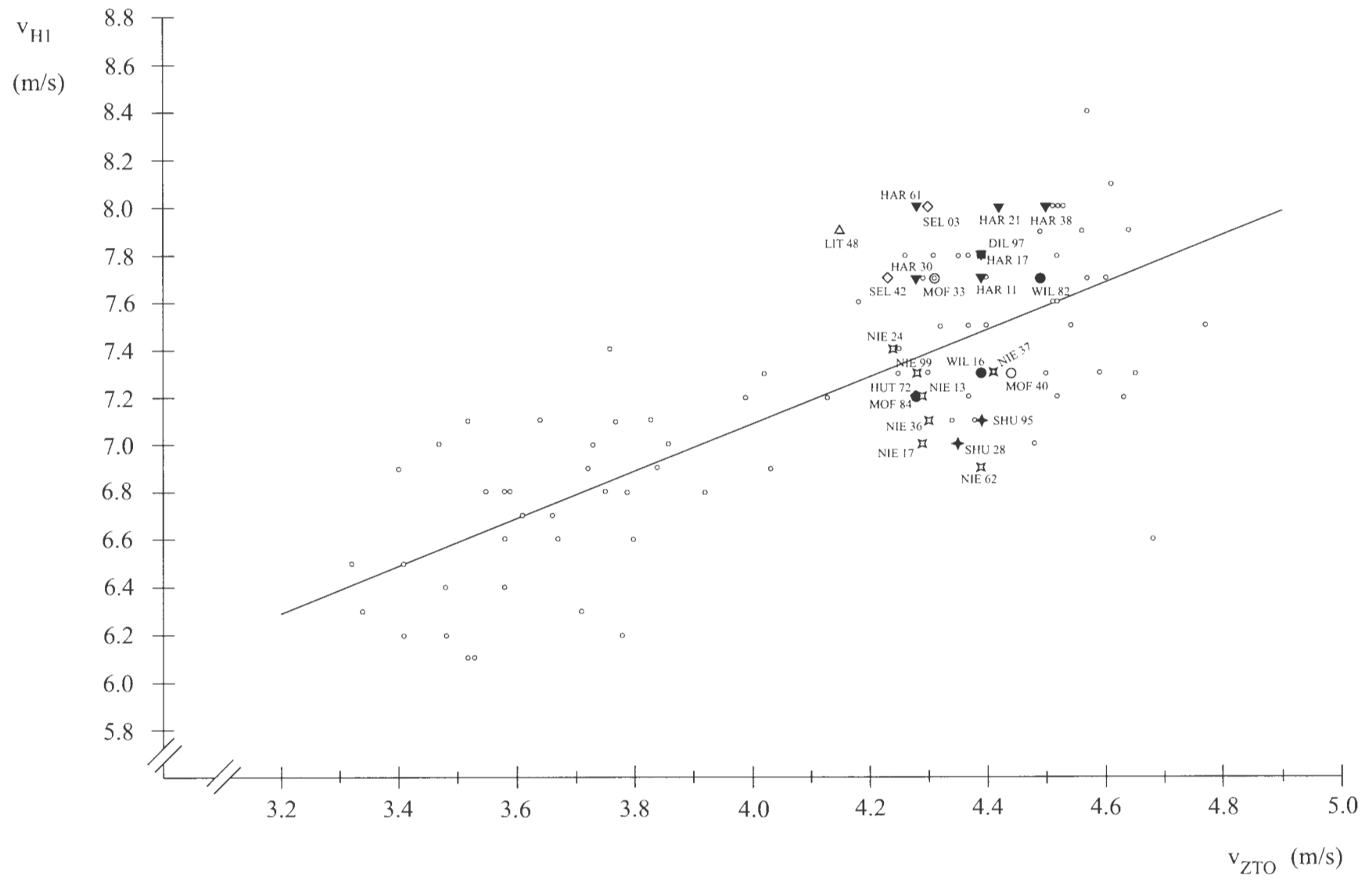

Figure 4

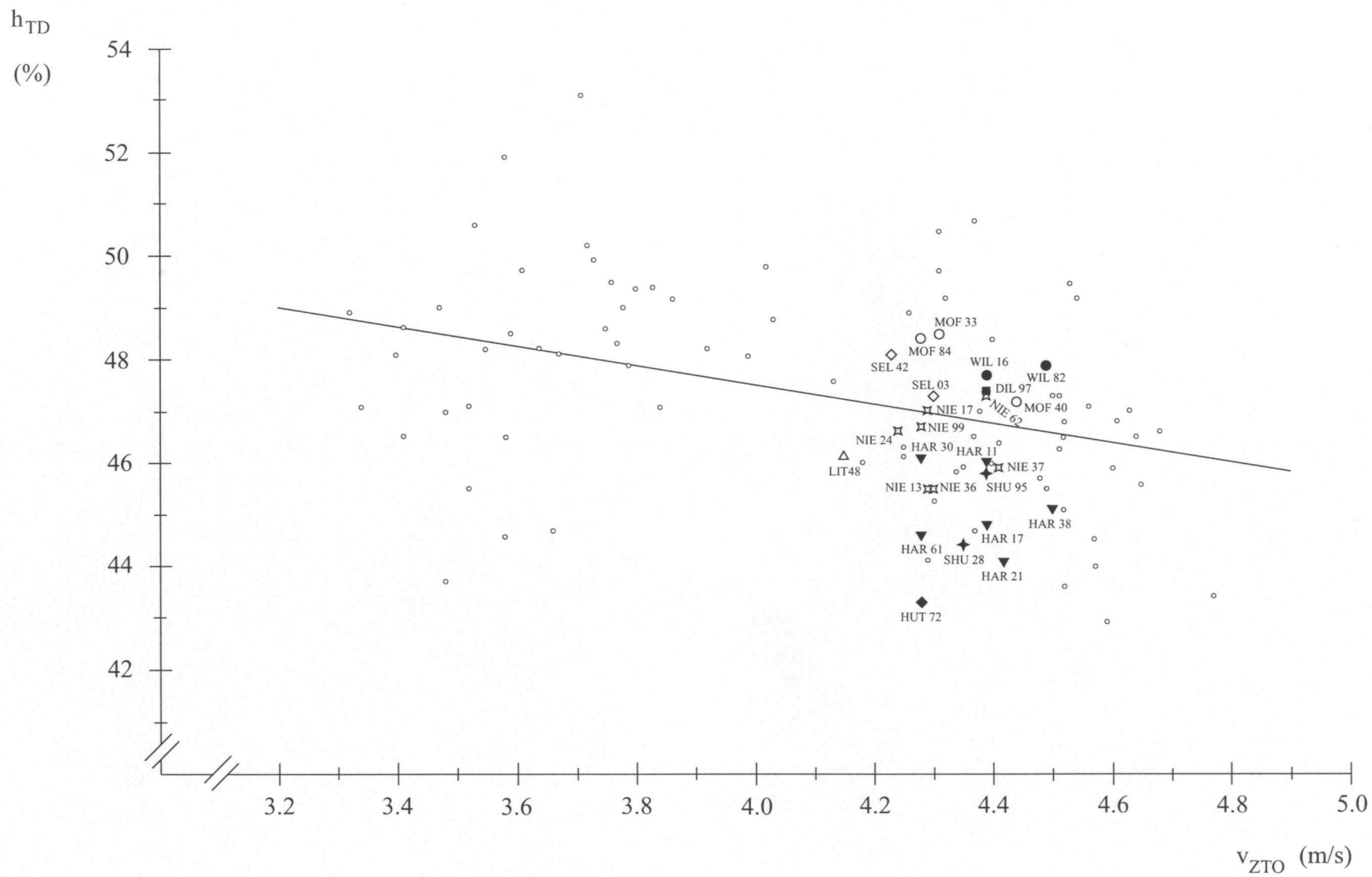

Figure 5

the graph represent progressively more demanding combinations. Each athlete's v_{ZTO} value (which needs to be obtained from Table 3) determines the appropriate diagonal line for that athlete in Figure 3. If an athlete is higher and/or to the left of the recommended diagonal line, as will often be the case, we will advise the athlete to move his/her point to the recommended diagonal line. If the athlete is already on the recommended diagonal line, we will advise the athlete to retain the current combination of run-up speed and c.m. height. If the athlete is somewhat lower and/or to the right of the recommended diagonal line, we will also advise the athlete to retain the current combination of run-up speed and c.m. height. This is because our recommended diagonal line is a rather conservative choice with a safety margin built into it. *[Note for other researchers (coaches and athletes can skip this): In statistical terms, the recommended diagonals were chosen to be only one standard deviation more demanding than the average.]* In the rare case that the athlete is much lower and/or much farther to the right than the recommended diagonal line, we will warn the athlete that such a combination might be excessively demanding in relation to the athlete's current leg strength capability.

We have a reasonably good idea of which is the appropriate diagonal line for each athlete. However, we do not know where the athlete's point should be located *along* that diagonal line. Coaches who are advocates for so-called "power jumping" will prefer the athlete's point to be farther down and to the left along the diagonal line, while coaches who are advocates for so-called "speed jumping" will prefer the athlete's point to be farther up and toward the right along the diagonal line. We are neutral in this dispute: As long as the athlete is on the recommended diagonal line, we consider the athlete to have an appropriate combination of speed and c.m. height at the end of the run-up. The only caution that we give is to avoid extreme values either far up and to the right or far down and to the left along the diagonal line, because both will tend to create problems later for the bar clearance. An extremely fast speed and high c.m. position at the end of the run-up will tend to leave the athlete with a lot of leftover horizontal speed at the end of the takeoff. This will make it impossible for the athlete to "drape" around the bar without knocking it down with either the shoulders or the calves. At the other extreme, a very slow speed and low c.m. position at the end of the run-up will tend to leave the athlete with only a small amount of leftover horizontal speed at the end of the takeoff. This will severely limit the amount of horizontal travel of the body after the end of the takeoff, and thus will make it difficult to avoid hitting

the bar either on the way up toward the peak of the jump or on the way down.

It is important to keep in mind that the regression lines in Figures 4 and 5 represent *average* values, not optimum values. They represent mediocre techniques that are not particularly bad but also not particularly good. For optimum technique, an athlete needs to be higher than the regression line of Figure 4 and/or lower than the regression line of Figure 5. In contrast, the diagonal lines in Figure 3 have already been adjusted to represent *optimum* values instead of average values. Therefore, if an athlete's point in Figure 3 is on the diagonal line recommended for that athlete (based on the athlete's v_{ZTO} value taken from Table 3), the athlete is considered to be at his/her optimum combination of speed and c.m. height at the end of the run-up.

(IMPORTANT CAUTION: Changing to a faster and/or lower run-up will put a greater stress on the takeoff leg, and thus it may increase the risk of injury if the leg is not strong enough. Therefore, it is always important to use caution in the adoption of a faster and/or lower run-up. If the desired change is very large, it would be advisable to make it gradually, over a period of time. In all cases, it may be wise to further strengthen the takeoff leg, so that it can withstand the increased force of the impact produced when the takeoff leg is planted.)

Vertical velocity of the c.m. at the start of the takeoff phase

The vertical velocity at the end of the takeoff phase, which is of crucial importance for the height of the jump, is determined by the vertical velocity at the start of the takeoff phase and by the change that takes place in its value during the takeoff phase. In normal high jumping, at the end of the run-up (that is, at the start of the takeoff phase) the athlete is moving fast forward, and also slightly downward. In other words, the vertical velocity at the start of the takeoff phase (v_{ZTD}) usually has a small negative value (i.e., downward). It is evident that for a given change in vertical velocity during the takeoff phase, the athlete with the smallest amount of negative vertical velocity at touchdown will jump the highest. The values of v_{ZTD} are shown in Table 3. The jumpers with the best techniques in this respect are those with the least negative v_{ZTD} values.

In each step of the run-up the c.m. normally moves up slightly as the athlete takes off from the ground, reaches a maximum height, and then drops down again before the athlete plants the next foot on the ground. In the last step of the run-up, if the takeoff foot is planted on the ground early, the takeoff phase will start before the c.m. acquires too much downward vertical velocity. To achieve this,

the athlete has to try to make the last two foot contacts with the ground very quickly one after the other. In other words, the tempo of the last two foot supports should be very fast.

If the length of the last step is very long, it could contribute to a late planting of the takeoff foot, which in turn could lead to a large negative value for v_{ZTD} . Table 2 shows the length of the last step of the run-up (SL_1). This length is expressed in meters, but to facilitate comparisons among athletes it is also expressed as a percent of the standing height of each athlete.

Another factor that has an influence on the vertical velocity at the start of the takeoff phase is the way in which the c.m. is lowered in the final part of the run-up. High jumpers can be classified into three groups, depending on the way in which they lower the c.m. Many athletes lower their c.m. early (two or three steps before the takeoff), and then they move relatively flat in the last step. These athletes typically have a moderate amount of downward vertical velocity at the instant that the takeoff phase starts. The second group of athletes keep their hips high until almost the very end of the run-up, and then they lower the c.m. in the last step. These athletes have a large negative vertical velocity at the start of the takeoff phase, regardless of how early they plant the takeoff foot on the ground. A third group of athletes lower the c.m. in the same way as the first group, but then they raise the c.m. again quite a bit as the non-takeoff leg pushes off into the last step. These athletes typically have a very small amount of downward vertical velocity at the start of the takeoff phase, and this is good, but they also waste part of their previous lowering of the c.m.

The first and the third techniques have both advantages and disadvantages, but the second technique seems to be less sound than the other two, because of the large downward vertical velocity that it produces at the instant of the start of the takeoff phase. There is a more detailed discussion of these three techniques in Appendix 1.

A graph showing the vertical motion of the c.m. in the final part of the run-up was produced for each athlete, and these graphs are inserted in the report after the individual analysis of each athlete.

Orientation of the takeoff foot, and potential for ankle and foot injuries

At the end of the run-up, the high jumper's c.m. is moving at an angle p_1 with respect to the bar (see "Approach angles"). During the takeoff phase, the athlete pushes on the ground vertically downward, and also horizontally. The horizontal force that the foot makes on the ground during the takeoff phase points forward, almost in line with the final direction

of the run-up, but usually it is also deviated slightly toward the landing pit (see Figure 6). (The reason for this deviation is explained in Appendix 3.)

Most high jumpers plant the takeoff foot on the ground with its longitudinal axis pointing in a direction that generally is not aligned with the final direction of the run-up nor with the horizontal force that the athlete is about to make on the ground: It is more parallel to the bar than either one of them. Since the horizontal reaction force that the foot receives from the ground is not aligned with the longitudinal axis of the foot, the force tends to make the foot roll inward. (See the sequence in Figure 7, obtained from a high-speed videotape taken during the 1988 International Golden High Jump Gala competition in Genk, Belgium –courtesy of Dr. Bart Van Gheluwe.) In anatomical terminology, this rotation is called "pronation of the ankle joint". It stretches the medial side of the joint, and produces compression in the lateral side of the joint. If the pronation is very severe, it can lead to injury of the ankle. It also makes the foot be supported less by the outside edge of the foot, and more by the longitudinal (forward-backward) arch of the foot on the medial side. According to Krahl and Knebel (1979), this can lead to injury of the foot itself.

Pronation of the ankle joint occurs in the takeoffs of many high jumpers. However, it can be difficult to see, depending on the position of the camera and the size of the image. Because of this, pronation of the ankle joint is often not clearly visible in our standard films or videotapes of high jumping competitions (and therefore it does not show in our computer graphics sequences either). This does not necessarily mean that there is no ankle pronation; it only means that we can't see it.

In an effort to diagnose the risk of ankle and foot injury for each analyzed high jumper, we measured angles e_1 (the angle between the longitudinal axis of the foot and the bar), e_2 (between the longitudinal axis of the foot and the final direction of the run-up), and e_3 (between the longitudinal axis of the foot and the horizontal force) in each jump. (See Figure 6.) The values of these angles are reported in Table 2. For diagnosis of the risk of injury, e_3 is the most important angle. Although the safety limit is not well known, anecdotal evidence suggests that e_3 values smaller than 20° are reasonably safe, that e_3 values between 20° and 30° are somewhat risky, and that e_3 values larger than 30° are dangerous.

Trunk lean

Figure 8 shows BFTD, BFTO, LRTD and LRTO, the backward/forward and left/right angles of lean of the trunk at the start and at the end of the takeoff phase, respectively. The values of these

Figure 6

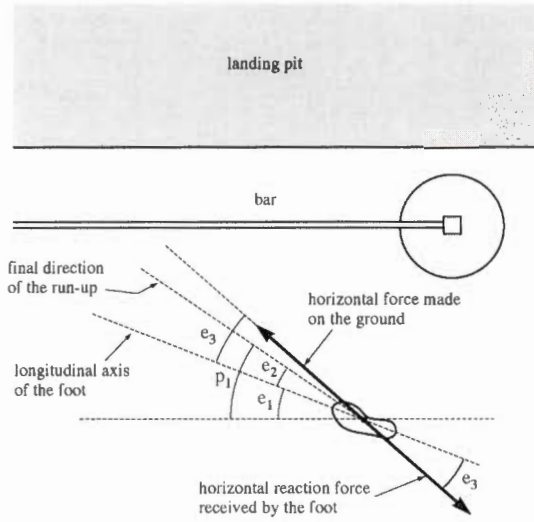

Figure 8

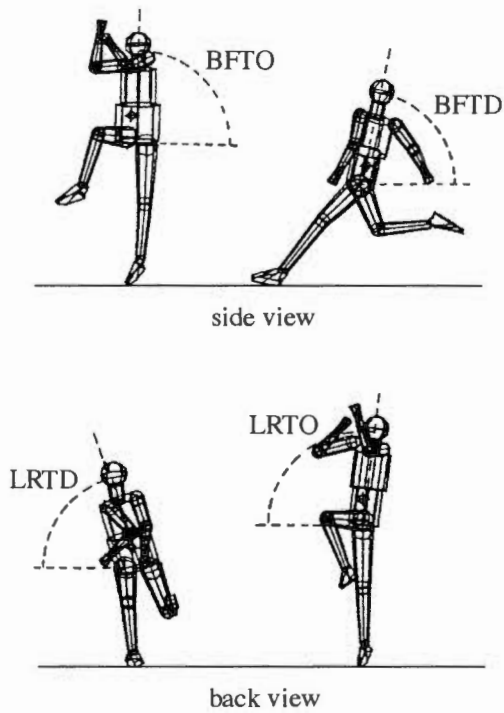

Figure 7



(videotape courtesy of Bart Van Gheluwe)

Table 4

Angles of tilt of the trunk [backward/forward at the start of the takeoff phase (BFTD) and at the end of the takeoff phase (BFTO), and the change in this angle during the takeoff phase (Δ BF); left/right at the start of the takeoff phase (LRTD) and at the end of the takeoff phase (LRTO), and the change in this angle during the takeoff phase (Δ LR)], activeness of the arm nearest to the bar (AAN) and of the arm farthest from the bar (AAF), summed activeness of the two arms (AAT), activeness of the lead leg (LLA), and summed activeness of the three free limbs (FLA). Note: Some of the values in this table may not fit perfectly with each other, because of rounding off.

Athlete	Trial and meet (*)	BFTD (°)	BFTO (°)	Δ BF (°)	LRTD (°)	LRTO (°)	Δ LR (°)	AAN (mm/m)	AAF (mm/m)	AAT (mm/m)	LLA (mm/m)	FLA (mm/m)
Dilling	97 U07	79	92	14	77	89	12	8.0	8.3	16.2	15.8	32.1
Harris	21 U01	74	88	14	72	85	13	5.0	7.9	12.9	9.3	22.2
	17 U02	76	85	9	73	96	23	7.9	9.0	17.0	10.4	27.4
	11 U03	75	86	11	76	92	15	11.1	9.5	20.6	11.6	32.2
	30 T04	73	88	16	72	89	18	9.0	8.0	17.0	8.7	25.7
	38 U06	77	87	10	74	94	20	5.6	7.2	12.8	11.9	24.7
	61 U07	76	87	11	74	97	23	8.7	7.6	16.3	12.9	29.3
Hutchinson	72 U07	75	92	17	87	102	15	12.2	13.1	25.3	25.5	50.8
Littleton	48 U07	84	90	6	79	101	21	8.2	7.2	15.5	15.3	30.8
Moffatt	33 T04	88	84	-4	76	102	26	4.1	6.0	10.1	16.9	27.0
	40 U06	83	79	-4	76	103	27	5.4	7.7	13.2	21.6	34.8
	84 U07	87	83	-4	79	101	22	5.0	7.0	12.0	19.6	31.6
Nieto	17 U99	80	89	10	74	96	22	5.0	9.9	14.9	17.4	32.3
	36 U01	68	83	15	75	100	25	4.0	11.1	15.1	13.4	28.4
	13 U02	72	81	9	74	97	23	4.9	8.5	13.4	16.5	29.9
	37 U03	75	85	10	72	100	28	5.0	8.7	13.6	16.3	30.0
	62 T04	77	80	3	77	102	26	7.5	11.5	19.0	20.2	39.2
	24 U06	83	95	12	75	98	23	4.5	9.1	13.6	16.1	29.7
	99 U07	82	89	7	73	97	24	7.3	10.0	17.3	18.1	35.4
Sellers	03 U06	74	88	14	81	101	20	7.4	12.8	20.2	20.8	41.0
	42 U07	79	92	13	84	106	22	7.6	13.8	21.4	20.9	42.3
Shunk	28 T04	71	82	10	72	97	25	6.1	10.3	16.4	15.3	31.7
	95 U07	73	81	7	74	100	26	6.4	9.7	16.1	16.9	33.0
Williams	16 T04	76	92	16	77	92	15	8.6	3.6	12.1	12.1	24.2
	82 U07	76	89	13	76	89	13	9.0	5.1	14.2	12.4	26.5

(*) U99 = 1999 USATF Ch.; U01 = 2001 USATF Ch.; U02 = 2002 USATF Ch.; U03 = 2003 USATF Ch.; T04 = 2004 U.S. Olympic Trials; U06 = 2006 USATF Ch.; U07 = 2007 USATF Ch.

angles are given in Table 4. The trunk normally has a backward lean at the start of the takeoff phase (BFTD). Then it rotates forward, and by the end of the takeoff it is close to vertical, and sometimes past the vertical (BFTO). Due to the curved run-up, the trunk normally has also a lateral lean toward the center of the curve at the start of the takeoff phase (LRTD). During the takeoff phase, the trunk rotates toward the right (toward the left in athletes who take off from the right foot), and by the end of the takeoff

it is usually somewhat beyond the vertical (LRTO). Up to 10° beyond the vertical (LRTO = 100°) may be considered normal. Table 4 also shows the values of Δ BF and Δ LR. These are the changes that occur during the takeoff phase in the backward/forward and left/right angles of tilt of the trunk, respectively.

Statistical information has shown that there is a relationship of the trunk lean angles with the vertical velocity of the athlete at the end of the takeoff phase, and consequently with the peak height of the c.m.: If

two athletes have similar run-up speed, height of the c.m. at the end of the run-up and arm actions during the takeoff phase (see below), the athlete with smaller BFTD, ΔBF , LRTD and ΔLR values generally obtains a larger vertical velocity by the end of the takeoff phase. This means that athletes with greater backward lean at the start of the takeoff phase and greater lateral lean toward the center of the curve at the start of the takeoff phase tend to jump higher. Also, for a given amount of backward lean at the start of the takeoff phase, the athletes who experience smaller changes in this angle during the takeoff phase generally jump higher, and for a given amount of lateral lean at the start of the takeoff phase, the athletes who experience smaller changes in this angle during the takeoff phase also tend to jump higher.

However, before jumping to conclusions and deciding that all high jumpers should lean backward and laterally as much as possible at the start of the takeoff phase, and then change those angles of lean as little as possible during the takeoff phase itself, it is necessary to take two points into consideration. First of all, small values of BFTD, ΔBF , LRTD and ΔLR are not only statistically associated with larger vertical velocities at the end of the takeoff phase (which is good), but also with less angular momentum (see below), and therefore with a less effective rotation during the bar clearance.

Also, we can't be completely certain that small values of BFTD, ΔBF , LRTD and ΔLR **produce** a takeoff that generates a larger amount of vertical velocity and therefore a higher peak height for the c.m. We don't understand well the cause-effect mechanisms behind the statistical relationships, and it is possible to offer alternative explanations, such as this one: Weaker athletes are not able to generate much lift, mainly because they are weak. Therefore, they are not able to jump very high. This makes them reach the peak of the jump relatively soon after takeoff. Consequently, they will want to rotate faster in the air to reach a normal horizontal layout position at the peak of the jump. For this, they will generate more angular momentum during the takeoff, which in turn will require larger values of BFTD, ΔBF , LRTD and ΔLR . We can't be sure of which interpretation is the correct one: Does the trunk tilt affect the height of the jump, or does the weakness of the athlete affect the height of the jump and (indirectly) the trunk tilt? Or are both explanations partly correct? At this point, we don't know for sure.

Arm and lead leg actions

The actions of the arms and of the lead leg during the takeoff phase are very important for the outcome of a high jump. When these free limbs are

accelerated upward during the takeoff phase, they exert by reaction a compressive force downward on the trunk. This force is transmitted through the takeoff leg to the ground. The increased downward vertical force exerted by the foot on the ground evokes by reaction an increased upward vertical force exerted by the ground on the athlete. This produces a larger vertical velocity of the c.m. of the athlete by the end of the takeoff phase, and consequently a higher jump.

There is no perfect way to measure how active the arms and the lead leg were during the takeoff phase of a high jump. In our reports we have progressively improved our measurement of this important technique factor; the data in the present report were calculated with our latest method which gives more meaningful values than some of the previous ones.

[Note for other researchers (coaches and athletes can skip this paragraph): In this report, arm activeness was expressed as the vertical range of motion of the c.m. of each arm during the takeoff phase (relative to the upper end of the trunk), multiplied by the fraction of the whole body mass that corresponds to the arm, and divided by the standing height of the subject. The activeness of the lead leg was similarly measured as the vertical range of motion of the c.m. of the lead leg during the takeoff phase (relative to the lower end of the trunk), multiplied by the fraction of the whole body mass that corresponds to the lead leg, and divided by the standing height of the subject. In effect, this means that the activeness of each free limb was expressed as the number of millimeters contributed by the limb motion to the lifting of the c.m. of the whole body during the takeoff phase, per meter of standing height. Defined in this way, the activeness of each free limb considers the limb's mass, its average vertical velocity during the takeoff phase, and the duration of this vertical motion. It allows the comparison of one jumper with another, and also direct comparison of the lead leg action with the arm actions.]

Table 4 shows the activeness of the arm nearest to the bar (AAN) and of the arm farthest from the bar (AAF), the summed activeness of the two arms (AAT), the activeness of the lead leg (LLA) and the combined activeness of all three free limbs (FLA). (As explained in the previous paragraph, coaches and athletes don't need to worry about the fine details of how these values were calculated; they only need to keep in mind that larger numbers indicate greater activeness of the limbs during the takeoff.)

Figure 9 shows a plot of AAF versus AAN for the analyzed trials. The farther to the right that a point is on the plot, the greater the activeness of the

Figure 9

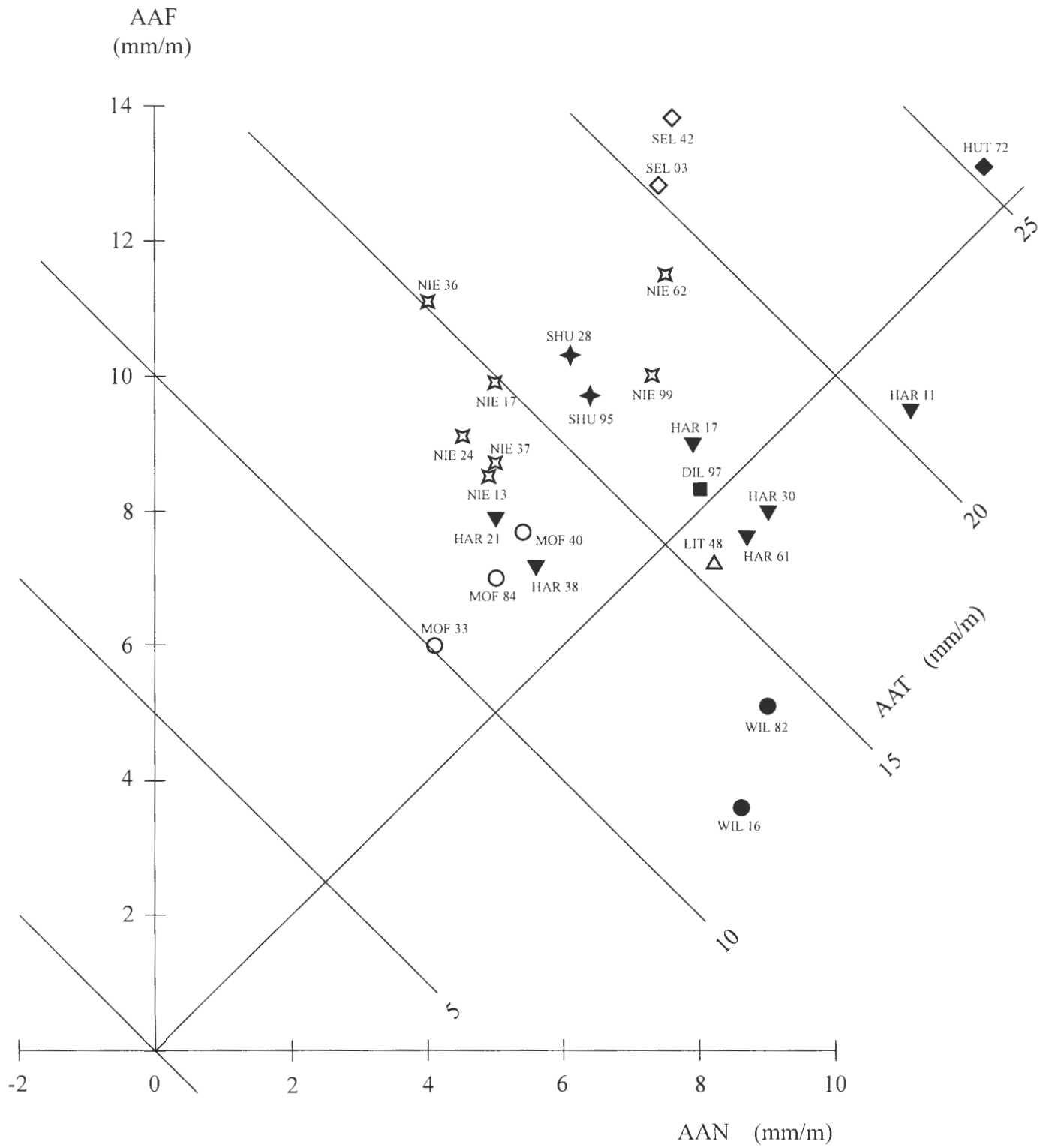

arm nearest to the bar; the higher up that a point is on the plot, the greater the activeness of the arm farthest from the bar. The ideal is to be as far to the right and as high up as possible on the graph, as this gives the largest values for the total arm action, AAT, also shown in the graph.

For a good arm action, both arms should swing strongly forward and up during the takeoff phase. The arms should not be too flexed at the elbow during the swing—a good elbow angle seems to be somewhere between full extension and 90° of flexion.

The diagonal line going from the lower left corner of Figure 9 toward the upper right part of the graph indicates the points for which both arms would have the same activeness. The positions of the points above the diagonal line reflect a well-established fact: High jumpers are generally more active with the arm that is farthest from the bar.

Some high jumpers (including many women) fail to prepare their arms correctly in the last steps of the run-up, and at the beginning of the takeoff phase the arm nearest to the bar is ahead of the body instead of behind it. From this position the arm is not able to swing strongly forward and upward during the takeoff, and these jumpers usually end up with small AAN values. These athletes should learn to bring both arms back in the final one or two steps of the run-up, so that both arms can later swing hard forward and up during the takeoff phase. Learning this kind of arm action will take some time and effort, but it should help these athletes to jump higher. If a jumper is unable to prepare the arms for a double-arm action, the forward arm should be in a low position at the start of the takeoff phase. That way, it can be thrown upward during the takeoff, although usually not quite as hard as with a double-arm action.

Figure 10 shows a plot of LLA versus AAT for the analyzed trials. The farther to the right that a point is on the plot, the greater the combined activeness of the arms; the higher up that a point is on the plot, the greater the activeness of the lead leg. The ideal is to be as far to the right and as high up as possible on the graph, as this gives the largest values for the total free limb action, FLA, also shown in the graph.

Takeoff time

The duration of the takeoff phase (T_{TO}) is shown in Table 5. (Due to the slow camera speeds used, the value of T_{TO} can easily be in error by 0.01 s, and sometimes by as much as 0.02 s.) This “takeoff time” is influenced by a series of factors. Some of them are beneficial for the jump; others are

detrimental. Short takeoffs go together with a strong action of the takeoff leg (good), but also with weak arm actions and with a high c.m. position at the start of the takeoff phase (bad). In sum, takeoff times are informative, but the length of the takeoff time by itself does not necessarily indicate good or bad technique.

Change in horizontal velocity during the takeoff phase

It was explained before that the athlete should have a large horizontal velocity at the instant immediately before the takeoff foot is planted on the ground to start the takeoff phase, and that therefore no horizontal velocity should be lost before that instant. However, the horizontal velocity should be reduced considerably during the takeoff phase itself. The losses of horizontal velocity that all high jumpers experience during the takeoff phase (see Δv_H in Table 3) are due to the fact that the jumper pushes forward on the ground during the takeoff phase, and therefore receives a backward reaction force from the ground. These losses of horizontal velocity during the takeoff phase are an intrinsic part of the takeoff process, and they are associated with the generation of vertical velocity. If an athlete does not lose much horizontal velocity during the takeoff phase, this may be a sign that the athlete is not making good use of the horizontal velocity obtained during the run-up. We could say that the athlete should produce a lot of horizontal velocity during the run-up so that it can then be lost during the takeoff phase while the athlete obtains vertical velocity. If not enough horizontal velocity is produced during the run-up, or if not enough of it is lost during the takeoff phase, we can say that the run-up is not being used appropriately to help the athlete to jump higher.

Height and vertical velocity of the c.m. at the end of the takeoff phase

The peak height that the c.m. will reach over the bar is completely determined by the end of the takeoff phase: It is determined by the height and the vertical velocity of the c.m. at the end of the takeoff.

At the instant that the takeoff foot loses contact with the ground, the c.m. of a high jumper is usually at a height somewhere between 68% and 73% of the standing height of the athlete. This means that tall high jumpers have a built-in advantage: Their centers of mass will generally be higher at the instant that they leave the ground.

The vertical velocity of the c.m. at the end of the takeoff phase (v_{ZTO} , shown in Table 3) determines how much higher the c.m. will travel beyond the takeoff height after the athlete leaves the ground.

Figure 10

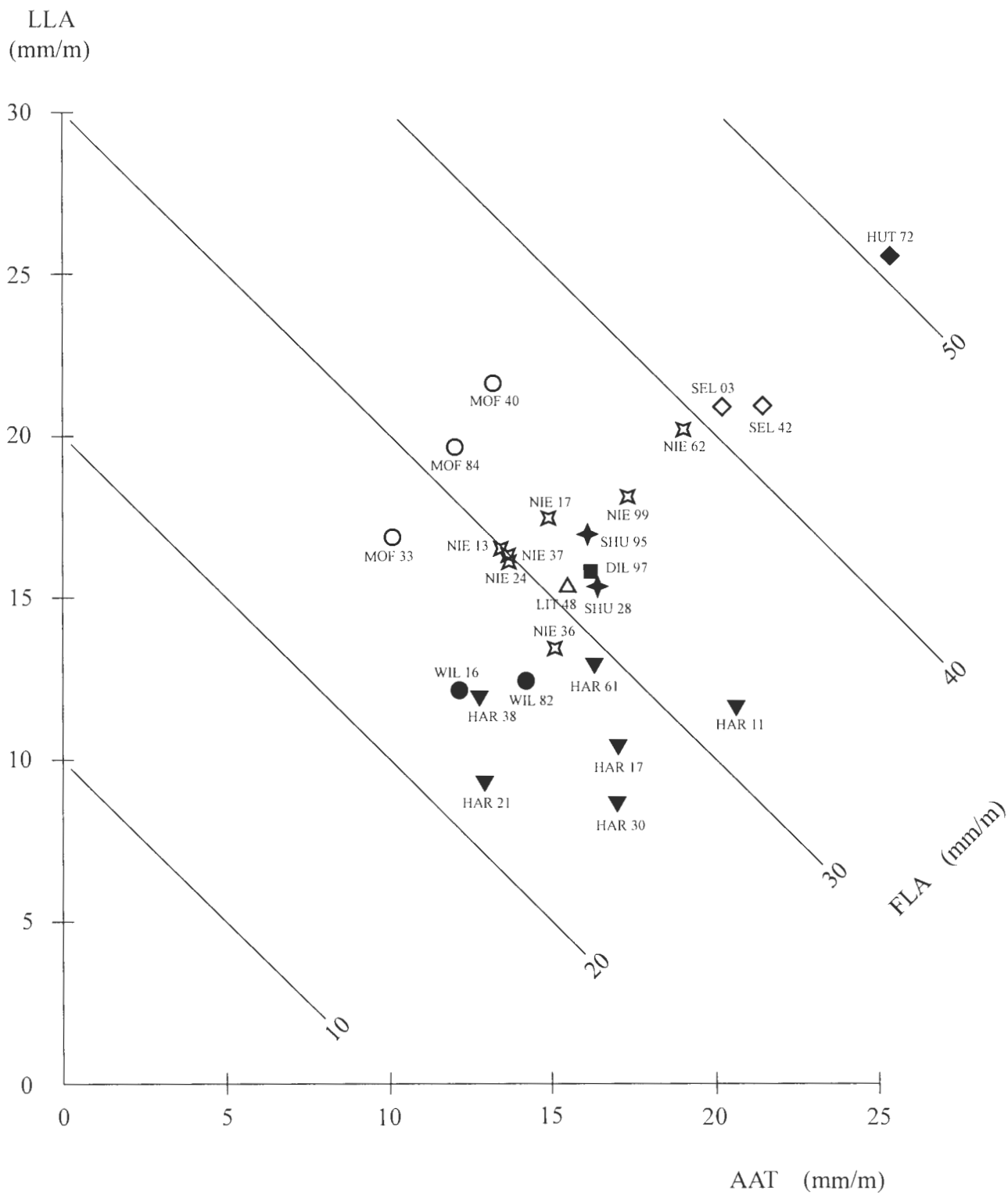

Table 5

Takeoff time (T_{FO}), height of the bar (h_{BAR}), outcome of the jump, maximum height of the c.m. (h_{PK}), clearance height in the plane of the standards (h_{CLS}), absolute clearance height (h_{CLA}), effectiveness of the bar clearance in the plane of the standards (Δh_{CLS}), and absolute effectiveness of the bar clearance (Δh_{CLA}); twisting angular momentum (H_T), forward somersaulting angular momentum (H_F), lateral somersaulting angular momentum (H_L) and total somersaulting angular momentum (H_S) during the airborne phase. Note: Some of the values in this table may not fit perfectly with each other, because of rounding off.

Athlete	Trial and meet (*)	T_{FO} (s)	h_{BAR} (m)	Outcome	h_{PK} (m)	h_{CLS} (m)	h_{CLA} (m)	Δh_{CLS} (m)	Δh_{CLA} (m)	H_T (**)	H_F (**)	H_L (**)	H_S (**)
Dilling	97 U07	0.17	2.27	clearance	2.36	2.27	2.28	-0.09	-0.08	30	80	35	90
Harris	21 U01	0.18	2.24	clearance	2.34	2.25	2.28	-0.09	-0.06	50	90	80	120
	17 U02	0.18	2.24	clearance	2.33	2.26	2.30	-0.07	-0.03	60	65	90	110
	11 U03	0.17	2.22	clearance	2.33	2.17	2.26	-0.14	-0.07	55	55	90	105
	30 T04	0.16	2.27	clearance	2.28	2.25	2.25	-0.03	-0.03	65	100	90	135
	38 U06	0.15	2.30	clearance	2.38	2.35	2.35	-0.03	-0.03	55	85	90	120
	61 U07	0.18	2.21	clearance	2.28	2.24	2.26	-0.04	-0.02	55	75	95	120
Hutchinson	72 U07	0.22	2.21	clearance	2.27	2.21	2.22	-0.06	-0.05	50	60	70	90
Littleton	48 U07	0.16	2.18	clearance	2.20	2.20	2.20	0.00	0.00	45	90	90	125
Moffatt	33 T04	0.17	2.27	clearance	2.35	2.26	2.30	-0.09	-0.05	40	50	90	100
	40 U06	0.18	2.30	clearance	2.41	2.32	2.33	-0.09	-0.08	50	45	95	110
	84 U07	0.18	2.24	clearance	2.33	2.25	2.27	-0.08	-0.06	40	45	95	105
Nieto	17 U99	0.19	2.25	clearance	2.30	2.30	2.30	0.00	0.00	35	85	95	125
	36 U01	0.20	2.27	miss	2.31	2.25	2.28	-0.06	-0.03	40	55	100	115
	13 U02	0.18	2.24	clearance	2.31	2.27	2.27	-0.04	-0.04	45	60	95	110
	37 U03	0.18	2.30	clearance	2.36	2.28	2.34	-0.08	-0.02	45	65	100	120
	62 T04	0.18	2.33	clearance	2.35	2.31	2.35	-0.04	0.00	55	70	95	115
	24 U06	0.18	2.24	miss	2.28	2.21	2.23	-0.07	-0.05	40	65	95	115
	99 U07	0.19	2.25	clearance	2.30	2.28	2.29	-0.02	-0.01	35	65	100	115
Sellers	03 U06	0.17	2.19	clearance	2.27	2.20	2.21	-0.07	-0.06	45	80	70	105
	42 U07	0.18	2.18	clearance	2.24	2.18	2.18	-0.06	-0.06	45	70	75	105
Shunk	28 T04	0.19	2.27	miss	2.25	2.21	2.22	-0.04	-0.03	60	75	90	115
	95 U07	0.19	2.27	miss	2.27	2.23	2.28	-0.04	+0.01	55	55	95	110
Williams	16 T04	0.16	2.24	clearance	2.28	2.25	2.25	-0.03	-0.03	50	90	75	120
	82 U07	0.15	2.24	clearance	2.32	2.25	2.27	-0.07	-0.05	30	80	75	110

(*) U99 = 1999 USATF Ch.; U01 = 2001 USATF Ch.; U02 = 2002 USATF Ch.; U03 = 2003 USATF Ch.; T04 = 2004 U.S. Olympic Trials; U06 = 2006 USATF Ch.; U07 = 2007 USATF Ch.

(**) Angular momentum units: $s^{-1} \cdot 10^{-3}$

Height of the bar, peak height of the c.m., and clearance height

The height of the bar (h_{BAR}), the maximum height reached by the c.m. (h_{PK}) and the outcome of the jump are shown in Table 5.

The true value of a high jump generally is not known: If the bar is knocked down, the jump is ruled a foul and the athlete gets zero credit, even though a hypothetical bar set at a lower height would have

been cleared successfully; if the bar stays up, the athlete is credited with the height at which the bar was set, even if the jumper had room to spare over it.

Using computer modeling and graphics, it is possible to estimate the approximate maximum height that an athlete would have been able to clear cleanly without touching the bar in a given jump ("clearance height"), regardless of whether the actual jump was officially a valid clearance or a foul.

Figure 11 shows three images of a high jumper's clearance of a bar set at 2.25 m. Figure 12 shows all the images obtained through video analysis of the bar clearance. In Figure 13 the drawing has been saturated with intermediate positions of the high jumper, calculated through a process called curvilinear interpolation. The scale in the "saturation drawing" shows that in this jump the athlete would have been able to clear a bar set in the plane of the standards at a height of 2.34 m (h_{CLS}) without touching it. A closer examination of Figure 13 also shows that the maximum height of the "hollow" area left below the body was not perfectly centered over the bar: If this athlete had taken off closer to the plane of the standards, he would have been able to clear a bar set at an absolute maximum height of 2.35 m (h_{CLA}) without touching it.

Due to errors in the digitization of the films or videotapes, in the thicknesses of the various body segments of the computer graphics model and in the degree of curvature of the trunk in the drawings, the value of the clearance height in the plane of the standards (h_{CLS}) and the value of the absolute clearance height (h_{CLA}) obtained using this method are not perfectly accurate. A test showed that h_{CLS} will be over- or underestimated on the average by between 0.02 m and 0.03 m, but this will be larger or smaller in individual cases. Therefore, the calculated clearance height values should be considered only rough estimates. It is also necessary to keep in mind that high jumpers can generally depress the bar about 0.02 m, sometimes 0.04 m, and occasionally 0.06 m or more without knocking it down.

The differences between the clearance heights and the peak height of the c.m. indicate the effectiveness of the bar clearance in the plane of the standards ($\Delta h_{CLS} = h_{CLS} - h_{PK}$) and the absolute effectiveness of the bar clearance ($\Delta h_{CLA} = h_{CLA} - h_{PK}$). Larger negative numbers indicate less effective bar clearances.

Table 5 shows the maximum height that the athlete would have been able to clear without touching the bar in the plane of the standards (h_{CLS}), the absolute maximum height that the athlete would have been able to clear without touching the bar (h_{CLA}), the effectiveness of the bar clearance in the plane of the standards (Δh_{CLS}), and the absolute effectiveness of the bar clearance (Δh_{CLA}) in the analyzed trials.

The most usual reasons for an ineffective bar clearance are: taking off too close or too far from the bar, insufficient amount of somersaulting angular momentum, insufficient twist rotation, poor arching, and bad timing of the arching/un-arching process. These aspects of high jumping technique will be discussed next.

Takeoff distance

The distance between the toe of the takeoff foot and the plane of the bar and the standards is called the "takeoff distance" (Figure 2). The value of this distance is shown in Table 2, and it is important because it determines the position of the peak of the jump relative to the bar: If an athlete takes off too far from the bar, the c.m. will reach its maximum height before crossing the plane of the standards, and the jumper will probably fall on the bar; if the athlete takes off too close to the bar, there will be a large risk of hitting the bar while the c.m. is on the way up, before reaching its maximum height. Different athletes usually need different takeoff distances. The optimum value for the takeoff distance of each athlete is the one that will make the c.m. of the jumper reach its maximum height more or less directly over the bar, and it will depend primarily on the final direction of the run-up and on the amount of residual horizontal velocity that the athlete has left after the completion of the takeoff phase.

In general, athletes who travel more perpendicular to the bar in the final steps of the run-up (indicated by large p_2 and p_1 angles in Table 2) will also travel more perpendicular to the bar after the completion of the takeoff phase (indicated by large p_0 angles in Table 2), and they will need to take off farther from the bar. In general, athletes who run faster in the final steps of the run-up (indicated by large values of v_{H2} and v_{H1} in Table 3) will also have more horizontal velocity left after takeoff (indicated by large values of v_{HTO} in Table 3); thus, they will travel through larger horizontal distances after the completion of the takeoff phase than slower jumpers, and they will also need to take off farther from the bar in order for the c.m. to reach its maximum height more or less directly over the bar.

High jumpers need to be able to judge after a miss whether the takeoff point might have been too close or too far from the bar. This can be done by paying attention to the time when the bar was hit. If the bar was hit a long time after the takeoff, this probably means that the bar was hit as the athlete was coming down from the peak of the jump, implying that the athlete took off too far from the bar, and in that case the athlete should move the starting point of the run-up slightly closer to the bar; if the bar was hit very soon after takeoff, this probably means that the bar was hit while the athlete was still on the way up toward the peak of the jump, implying that the takeoff point was too close to the bar, and in that case the athlete should move the starting point of the run-up slightly farther from the bar.

Angular momentum

Angular momentum (also called "rotary

Figure 11

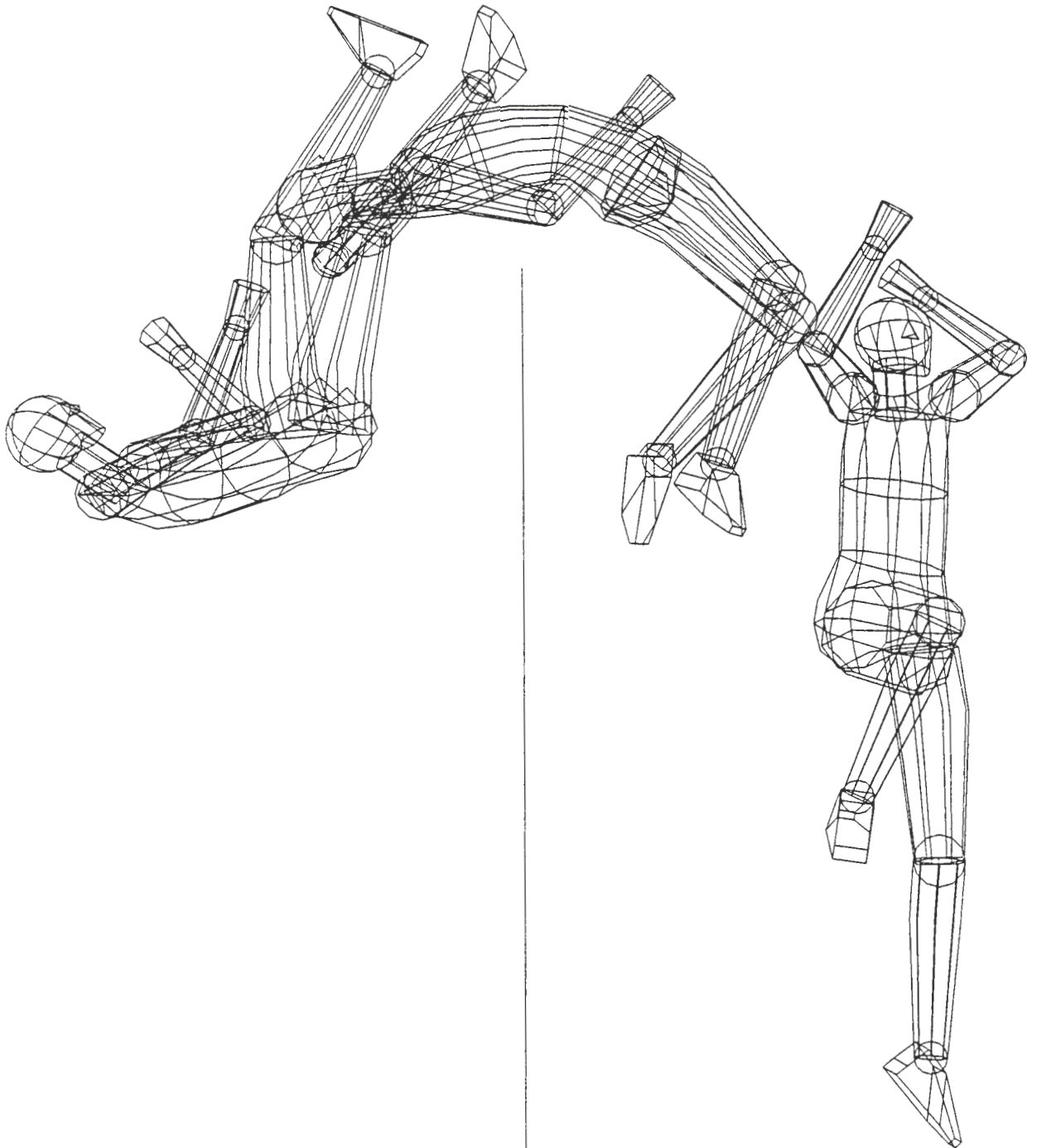

HARKEN #34 062787 2.25 M CLEARANCE

Figure 12

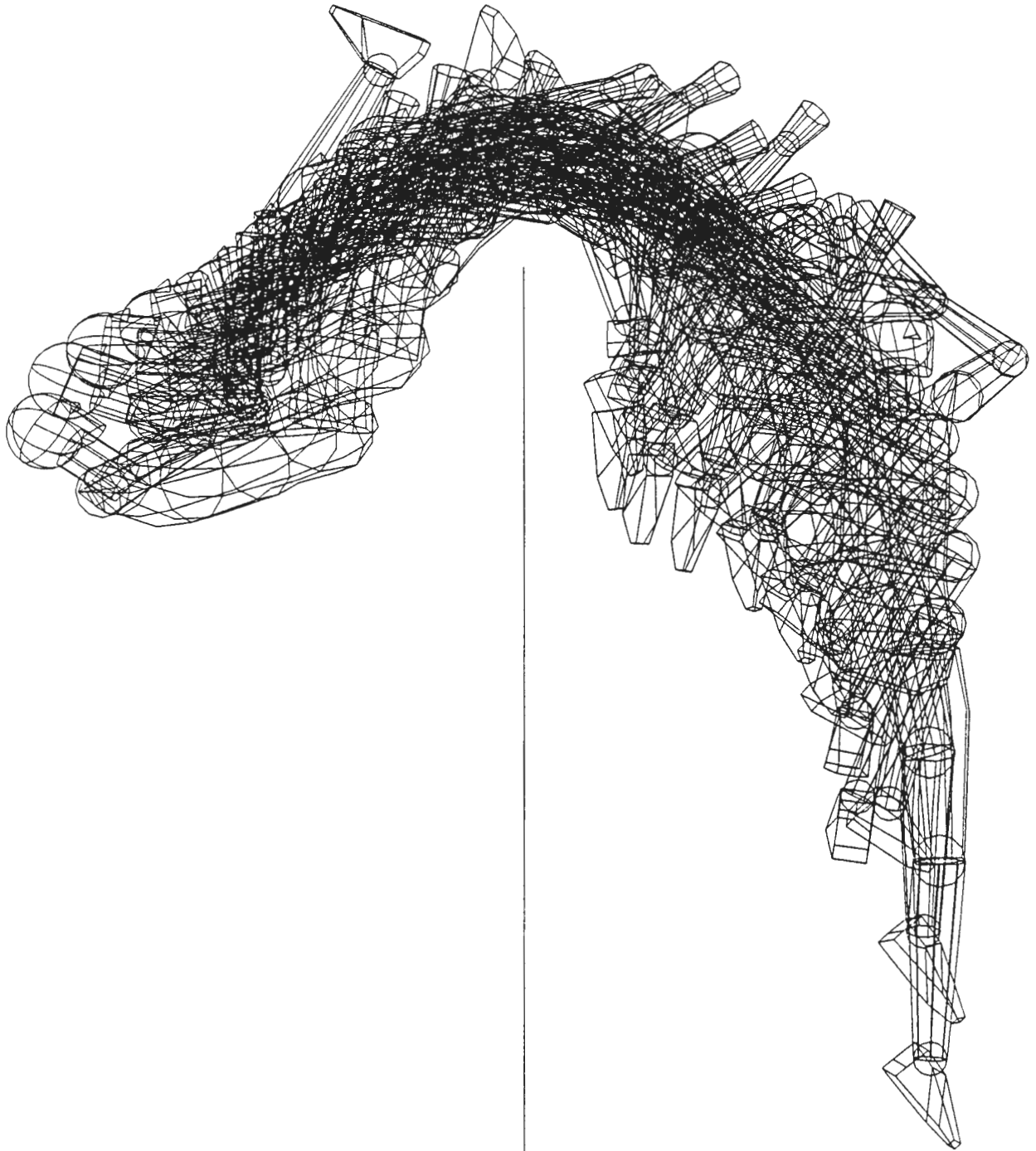

HARKEN #34 062787 2.25 M CLEARANCE

Figure 13

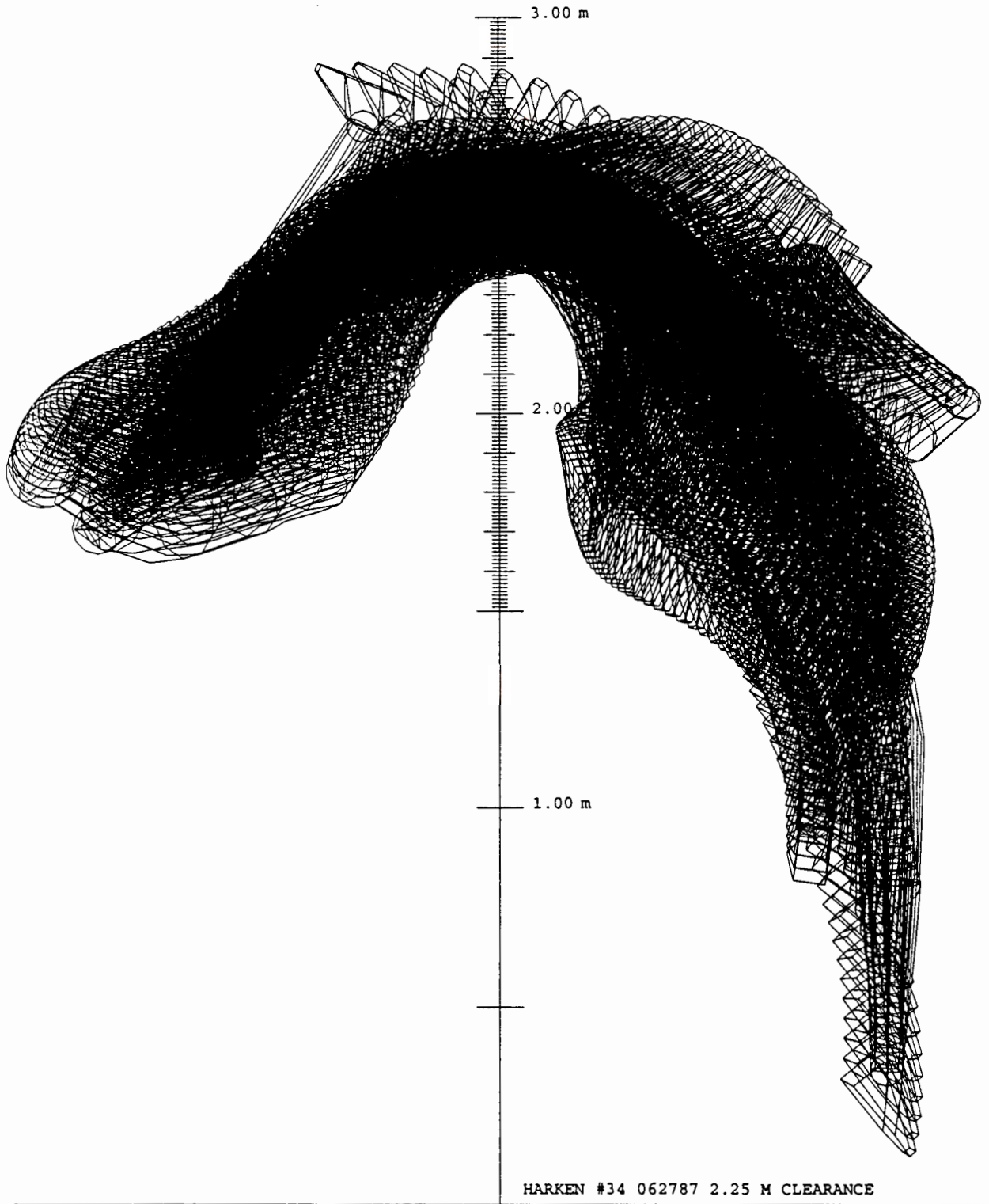

momentum”) is a mechanical factor that makes the athlete rotate. High jumpers need the right amount of angular momentum to make in the air the rotations necessary for a proper bar clearance. The athlete obtains the angular momentum during the takeoff phase, through the forces that the takeoff foot makes on the ground; the angular momentum cannot be changed after the athlete leaves the ground.

The bar clearance technique of a Fosbury-flop can be described roughly as a twisting somersault. To a great extent, the twist rotation (which makes the athlete turn the back to the bar during the ascending part of the flight path) is generated by swinging the lead leg up and somewhat away from the bar during the takeoff, and sometimes also by actively turning the shoulders and arms during the takeoff in the desired direction of the twist. These actions create angular momentum about a vertical axis. This is called the twisting angular momentum, H_T . The H_T values of the analyzed athletes are shown in Table 5. Most high jumpers have no difficulty obtaining an appropriate amount of H_T . (However, we will see later that the actions that the athlete makes in the air, as well as other factors, can also significantly affect whether the high jumper will be perfectly face-up at the peak of the jump, or tilted to one side with one hip lower than the other.)

The somersault rotation, which will make the shoulders go down while the knees go up, results from two components: a forward somersaulting component and a lateral somersaulting component.

(a) Forward somersaulting angular momentum (H_F) During the takeoff phase, the athlete produces angular momentum about a horizontal axis perpendicular to the final direction of the run-up (see Figure 14a and the sequence at the top of Figure 15). This forward rotation is similar to the one produced when a person hops off from a moving bus facing the direction of motion of the bus: After the feet hit the ground, the tendency is to rotate forward and fall flat on one's face. It can be described as angular momentum produced by the checking of a linear motion.

The tilt angles of the trunk at the start and at the end of the takeoff phase (see “Trunk lean”) are statistically related to the angular momentum obtained by the athlete. Large changes of the trunk tilt from a backward position toward vertical during the takeoff phase are associated with a larger amount of forward somersaulting angular momentum. This makes sense, because athletes with a large amount of forward somersaulting angular momentum at the end of the takeoff phase should also be expected to have a large amount of it already during the takeoff phase, and this should contribute to a greater forward rotation of the body in general and of the trunk

during the takeoff phase.

Statistics show that jumpers with a very large backward lean at the start of the takeoff phase (small BFTD angles) do not get quite as much forward somersaulting angular momentum as other jumpers. The reasons for this are not completely clear.

The forward somersaulting angular momentum can also be affected by the actions of the arms and lead leg. Wide swings of the arms and of the lead leg during the takeoff can help the athlete to jump higher (see “Arm and lead leg actions” above). However, in a view from the side (top sequence in Figure 16) they also imply backward (clockwise) rotations of these limbs, which can reduce the total forward somersaulting angular momentum of the body.

To diminish this problem, some high jumpers turn their back toward the bar in the last step of the run-up, and then swing the arms diagonally forward and away from the bar during the takeoff phase (see Figure 17). Since this diagonal arm swing is not a perfect backward rotation, it interferes less with the generation of forward somersaulting angular momentum.

Figure 14

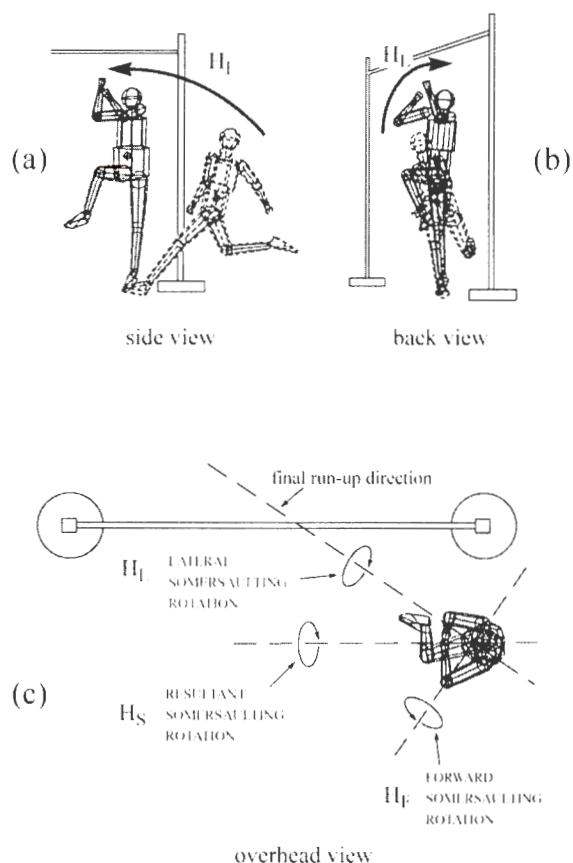

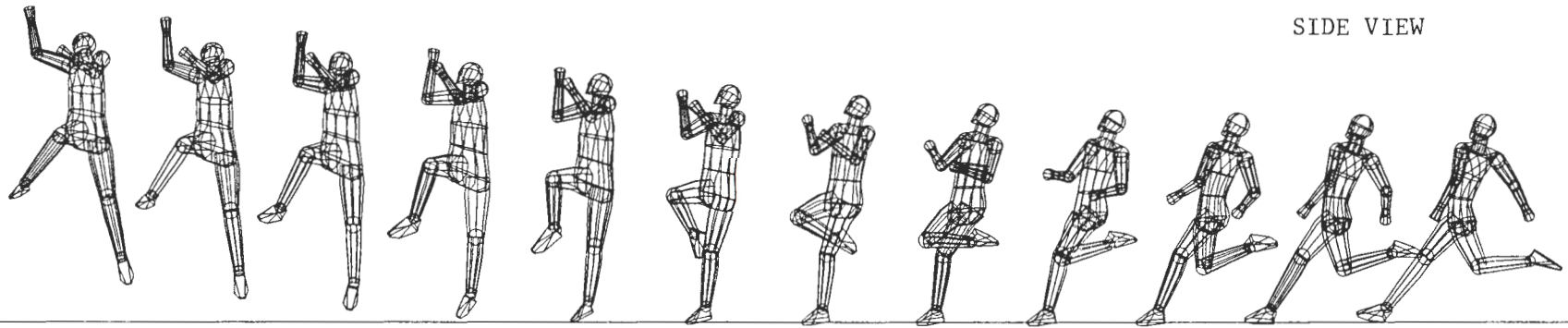

SIDE VIEW

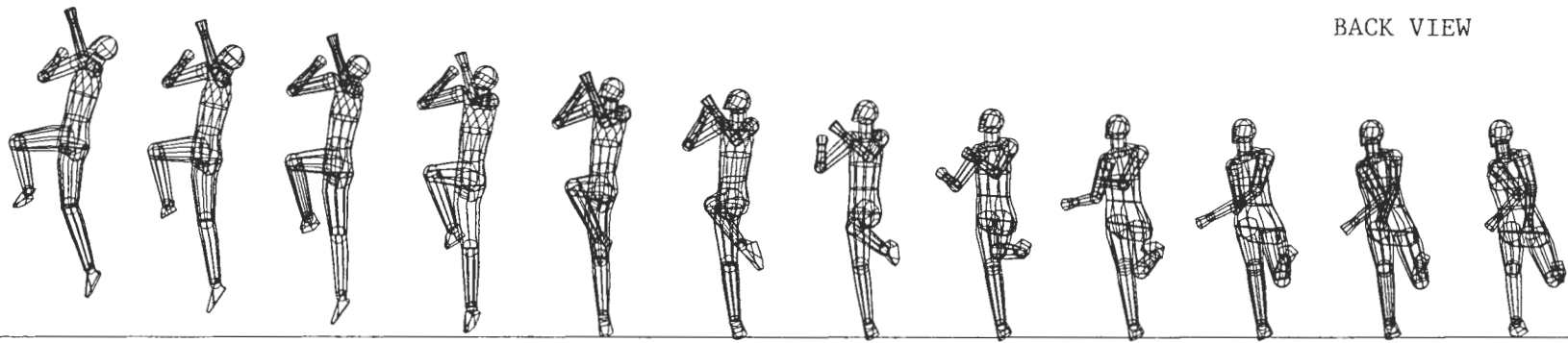

BACK VIEW

10.22 10.20 10.18 10.16 10.14 10.12 10.10 10.08 10.06 10.04 10.02 10.00

Figure 15

DIRECT FORWARD ARM SWING

SIDE VIEW

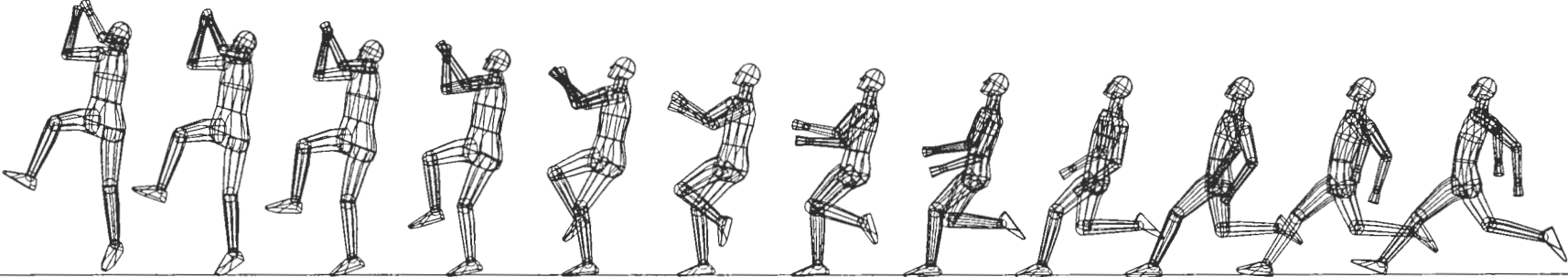

BACK VIEW

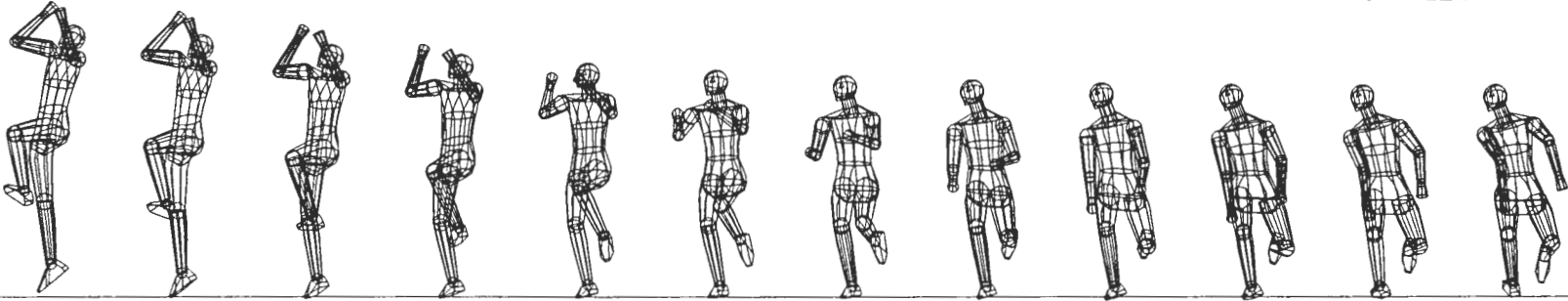

10.22 10.20 10.18 10.16 10.14 10.12 10.10 10.08 10.06 10.04 10.02 10.00

Figure 16

DIAGONAL ARM SWING

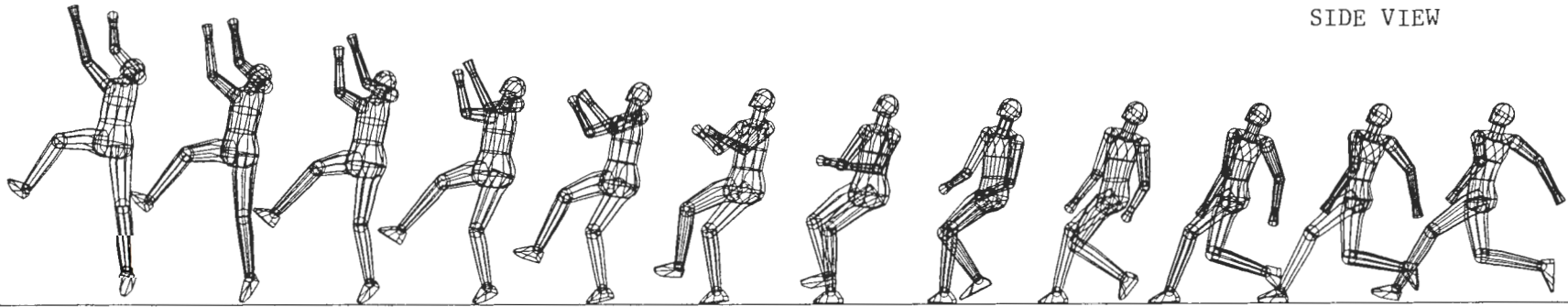

SIDE VIEW

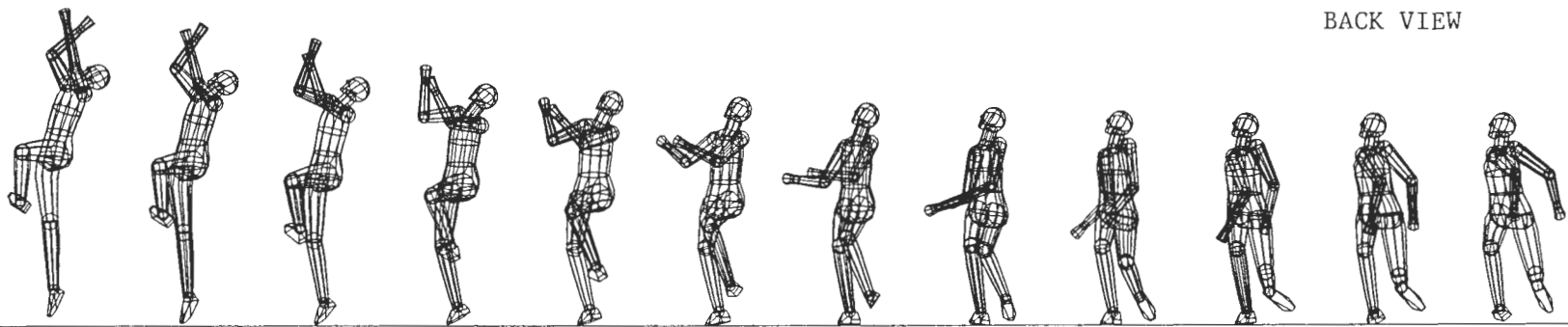

BACK VIEW

10.22 10.20 10.18 10.16 10.14 10.12 10.10 10.08 10.06 10.04 10.02 10.00

(b) Lateral somersaulting angular momentum (H_L) During the takeoff phase, angular momentum is also produced about a horizontal axis in line with the final direction of the run-up (see Figure 14b and the bottom sequence in Figure 15). In a rear view of an athlete who takes off from the left leg, this angular momentum component appears as a clockwise rotation.

If the jumper made use of a straight run-up, in a rear view the athlete would be upright at touchdown, and leaning toward the bar at the end of the takeoff. Since a leaning position would result in a lower height of the c.m. at the end of the takeoff phase, the production of angular momentum would thus cause a reduction in the vertical range of motion of the c.m. during the takeoff phase. However, if the athlete uses a curved run-up, the initial lean of the athlete to the left at the end of the approach run may allow the athlete to be upright at the end of the takeoff phase (see Figure 14b and the bottom sequence in Figure 15). The final upright position contributes to a higher c.m. position at the end of the takeoff phase. Also, the initial lateral tilt contributes to a lower c.m. position at the start of the takeoff phase. Therefore the curved run-up, together with the generation of lateral somersaulting angular momentum, contributes to increase the vertical range of motion of the c.m. during the takeoff phase, and thus permits greater lift than if a straight run-up were used. (However, some caution is necessary here, since statistical information suggests that jumpers with an excessive lean toward the center of the curve at the start of the takeoff phase tend to get a smaller amount of lateral somersaulting angular momentum than jumpers with a more moderate lean. The reasons for this are not clear.)

There is some statistical association between large changes in the left/right tilt angle of the trunk during the takeoff phase and large amounts of lateral somersaulting angular momentum at the end of the takeoff phase. This makes sense, because athletes with a large amount of lateral somersaulting angular momentum at the end of the takeoff phase should also be expected to have a large amount of it already during the takeoff phase, which should contribute to a greater rotation of the trunk during the takeoff phase from its initial lateral direction toward the vertical.

The reader should be reminded at this point that although large changes in tilt during the takeoff phase and, to a certain extent, small backward and lateral leans of the trunk at the start of the takeoff phase (i.e., large BFTD and LRTD values) are associated with increased angular momentum, they are also statistically associated with reduced vertical velocity at the end of the takeoff phase, and therefore with a reduced maximum height of the c.m. at the peak of the jump. This supports the intuitive feeling of high

jumpers that it is necessary to seek a compromise between lift and rotation.

The bottom sequence in Figure 17 shows that in an athlete who takes off from the left leg a diagonal arm swing is associated with a clockwise motion of the arms in a view from the back, and therefore it contributes to the generation of lateral somersaulting angular momentum.

High jumpers usually have more lateral than forward somersaulting angular momentum. The sum of these two angular momentum components adds up to the required total (or "resultant") somersaulting angular momentum, H_S (Figure 14c). (This is not a simple addition; the formula is $H_S = \sqrt{H_F^2 + H_L^2}$.)

The forward (H_F), lateral (H_L) and total (H_S) somersaulting angular momentum values of the analyzed athletes are shown in Table 5, and in graphical form in Figure 18. (To facilitate comparisons among athletes, the angular momentum values have been normalized for the weight and standing height of each athlete.) In general, athletes with more angular momentum tend to rotate faster.

Female high jumpers tend to acquire more angular momentum than male high jumpers. This is because the women don't jump quite as high, and therefore they need to rotate faster to compensate for the smaller amount of time that they have available between the takeoff and the peak of the jump.

Adjustments in the air

After the takeoff is completed, the path of the c.m. is totally determined, and nothing can be done to change it. However, this does not mean that the paths of all parts of the body are determined. What cannot be changed is the path of the point that represents the average position of all body parts (the c.m.), but it is possible to move one part of the body in one direction if other parts are moved in the opposite direction. Using this principle, after the shoulders pass over the bar the high jumper can raise the hips by lowering the head and the legs. For a given position of the c.m., the farther the head and the legs are lowered, the higher the hips will be lifted. This is the reason for the arched position on top of the bar.

To a great extent, the rotation of the high jumper in the air is also determined once the takeoff phase is completed, because the angular momentum of the athlete cannot be changed during the airborne phase. However, some alterations of the rotation are still possible. By slowing down the rotations of some parts of the body, other parts of the body will speed up as a compensation, and vice versa. For instance, the athlete shown in Figure 19a slowed down the counterclockwise rotation of the takeoff leg shortly

Figure 18

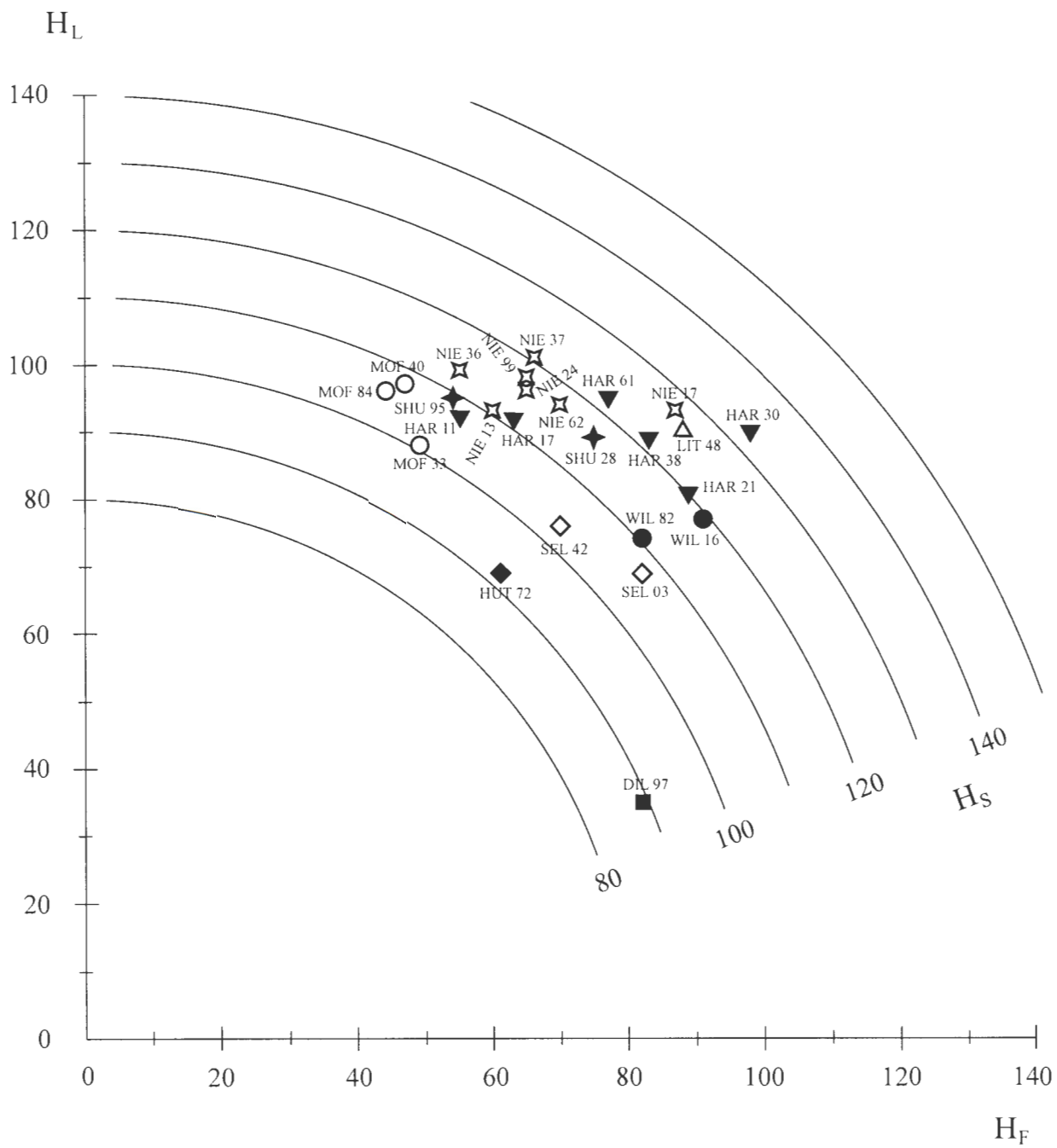

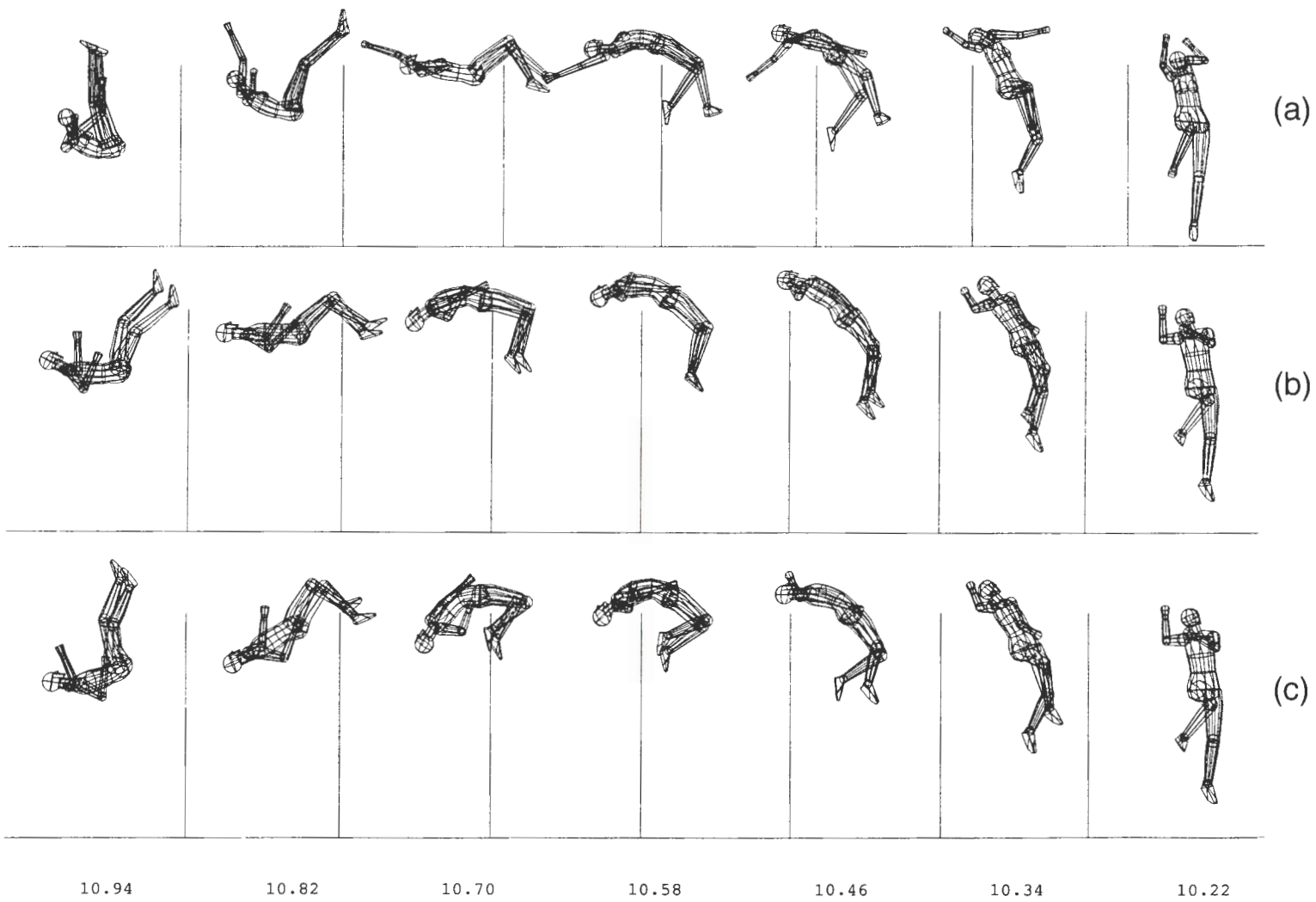

Figure 19

after the takeoff phase was completed, by flexing at the knee and extending at the hip ($t = 10.34 - 10.58$ s). In reaction, this helped the trunk to rotate faster counterclockwise, and therefore contributed to produce the horizontal position shown by the trunk at $t = 10.58$ s. Later, from $t = 10.58$ to $t = 10.82$ s, the athlete slowed down the counterclockwise rotation of the trunk, and even reversed it into a clockwise rotation; in reaction, the legs simultaneously increased their speed of rotation counterclockwise, and thus cleared the bar ($t = 10.58 - 10.82$ s).

The principles of action and reaction just described both for translation and rotation result in the typical arching and un-arching actions of high jumpers over the bar: The athlete needs to arch in order to lift the hips, and then to un-arch in order to speed up the rotation of the legs. As the body un-arches, the legs go up, but the hips go down. Therefore, timing is critical. If the body un-arches too late, the calves will knock the bar down; if the body un-arches too early, the athlete will “sit” on the bar and will also knock it down.

There can be several reasons for an athlete's weak arching. The athlete may be unaware that he/she is not arching enough. Or the athlete is not able to coordinate properly the necessary actions of the limbs. Or the athlete is not flexible enough. Or the athlete *is* flexible enough but has weak abdominal muscles and hip flexor muscles (the muscles that pass in front of the hip joint), and therefore is reluctant to arch very much since he/she is aware that the necessary un-arching action that will be required later will be impossible to execute with the necessary forcefulness due to the weakness of the abdominal and hip flexor muscles.

Another way in which rotation can be changed is by altering the “moment of inertia” of the body. The moment of inertia is a number that indicates whether the various parts that make up the body are close to the axis of rotation or far from it. When many parts of the body are far from the axis of rotation, the moment of inertia of the body is large, and this decreases the speed of turning about the axis of rotation. Vice versa, if most parts of the body are kept close to the axis of rotation, the moment of inertia is small, and the speed of rotation increases. This is what happens to figure skaters in a view from overhead when they spin: As they bring their arms closer to the vertical axis of rotation, they spin faster about the vertical axis. In high jumping, rotation about a horizontal axis parallel to the bar (i.e., the somersault) is generally more important than rotation about the vertical axis, but the same principle is at work. The jumps shown in Figures 19b and 19c both had the same amount of somersaulting angular momentum. However, the athlete in Figure 19c

somersaulted faster: Both jumpers had the same tilt at $t = 10.22$ s, but at $t = 10.94$ s the athlete in Figure 19c had a more backward-rotated position than the athlete in Figure 19b. The faster speed of rotation of the jumper in Figure 19c was due to his more compact body configuration in the period between $t = 10.46$ s and $t = 10.70$ s. It was achieved mainly through a greater flexion of the knees. This configuration of the body reduced the athlete's moment of inertia about an axis parallel to the bar, and made him somersault faster. (The jumps shown in Figures 19b and 19c were artificial jumps produced using computer simulation –see below. This ensured that the athlete had exactly the same position at takeoff and the same amount of angular momentum in both jumps.)

The technique used by the athlete in Figure 19c can be very helpful for high jumpers with low or moderate amounts of somersaulting angular momentum. Both jumps shown in Figures 19b and 19c had the same amount of angular momentum ($H_S = 110$), and the center of mass reached a peak height 0.07 m higher than the bar in both jumps. While the athlete in Figure 19b hit the bar with his calves ($t = 10.82$ s), the faster somersault rotation of the athlete in Figure 19c helped him to pass all parts of the body over the bar with some room to spare.

In the rare cases in which a high jumper has a very large amount of angular momentum, the technique shown in Figure 19c could be a liability, because it might accelerate the rotation so much that the shoulders will hit the bar on the way up. For athletes with a large amount of angular momentum, it will be better to keep the legs more extended on the way up to the bar, following the body configuration pattern shown in Figure 19b. This will temporarily slow down the backward somersault, and thus prevent the athlete from hitting the bar with the shoulders on the way up to the bar. (Of course, the athlete will still need to arch and un-arch with good timing over the bar.)

The twist rotation; problems in its execution

It was pointed out earlier that the twist rotation in high jumping is produced to a great extent by the twisting component of angular momentum, H_T . But it was also mentioned that other factors could affect whether the jumper would be perfectly face-up at the peak of the jump, or tilted to one side with one hip lower than the other. One of the most important of these factors is the proportion between the sizes of the forward and lateral components of the somersaulting angular momentum. We will now see how this works.

Figure 20 shows sketches of a hypothetical high jumper at the end of the takeoff phase and after three

Figure 20

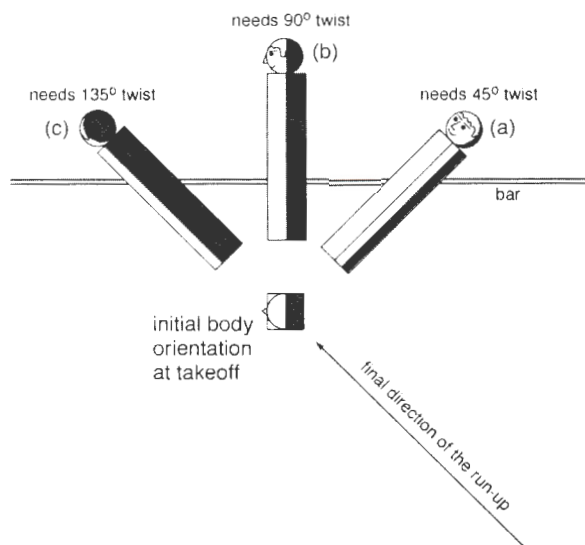

pure somersault rotations in different directions (*with no twist*), all viewed from overhead. For simplicity, we have assumed that the final direction of the run-up was at a 45° angle with respect to the bar. A normal combination of forward and lateral components of somersaulting angular momentum would produce at the peak of the jump the position shown in image b, which would require in addition 90° of twist rotation to generate a face-up orientation. If instead an athlete generated only *lateral* somersaulting angular momentum, the result would be the position shown in image a, which would require only about 45° of twist rotation to achieve a face-up orientation; if the athlete generated only *forward* somersaulting angular momentum, the result would be the position shown in image c, which would require about 135° of twist rotation to achieve a face-up orientation. It is very unusual for high jumpers to have only lateral or forward somersaulting angular momentum, but many jumpers have much larger amounts of one than of the other. The example shows that jumpers with particularly large amounts of forward somersaulting angular momentum and small amounts of lateral somersaulting angular momentum will need to twist more in the air if the athlete is to be face up at the peak of the jump. Otherwise, the body will be tilted, with the hip of the lead leg lower than the hip of the takeoff leg. Conversely, jumpers with particularly large amounts of lateral somersaulting angular momentum and small amounts of forward somersaulting angular momentum will need to twist less in the air than other jumpers in order to be perfectly face up at the peak of the jump. Otherwise, the body will be tilted, with the hip of the takeoff leg

lower than the hip of the lead leg.

Another point that we have to take into account is that, while the twisting component of angular momentum (H_T) is a major factor in the generation of the twist rotation in high jumping, it is generally not enough to produce the necessary face-up position on top of the bar: In addition, the athlete also needs to use rotational action and reaction about the longitudinal axis of the body to increase the amount of twist rotation that occurs in the air. In a normal high jump, the athlete needs to achieve about 90° of twist rotation between takeoff and the peak of the jump. Approximately half of it (about 45°) is produced by the twisting angular momentum; the other half (roughly another 45°) needs to be produced through rotational action and reaction. Rotational action and reaction is sometimes called “catting” because cats dropped in an upside-down position with no angular momentum use a mechanism of this kind to land on their feet.

The catting that takes place in the twist rotation of a high jump is difficult to see, because it is obscured by the somersault and twist rotations produced by the angular momentum. If we could “hide” the somersault and twist rotations produced by the angular momentum, we would be able to isolate the catting rotation, and see it clearly. To achieve that, we would need to look at the high jumper from the viewpoint of a rotating camera. The camera would need to somersault with the athlete, staying aligned with the athlete's longitudinal axis. The camera would also need to twist with the athlete, just fast enough to keep up with the portion of the twist rotation produced by the twisting component of angular momentum. That way, all that would be left would be the rotation produced by the catting, and this rotation is what would be visible in the camera's view. It is impossible to make a real camera rotate in such a way, but we can use a computer to calculate how the jump would have appeared in the images of such a camera if it had existed. This is what is shown in Figure 21.

The sequence in Figure 21 covers the period between takeoff and the peak of the jump, and progresses from left to right. All the images are viewed from a direction aligned with the longitudinal axis of the athlete. (The head is the part of the athlete nearest to the “camera”.) As the jump progressed, the camera *somersaulted* with the athlete, so it stayed aligned with the athlete's longitudinal axis. The camera also *twisted* counterclockwise with the athlete, just fast enough to keep up with the portion of the twist rotation produced by the twisting component of angular momentum. Figure 21 shows a clear counterclockwise rotation of the hips (about 45°) between the beginning and the end of the

Figure 21

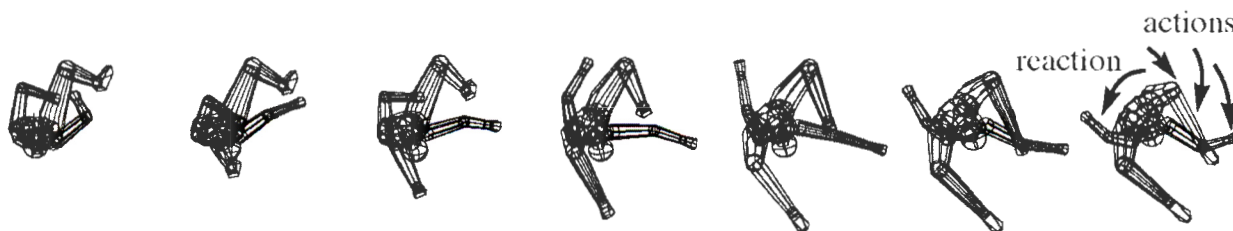

sequence. This implies that the athlete rotated counterclockwise faster than the camera, i.e., faster than the part of the twist rotation produced by the twisting component of angular momentum. The counterclockwise rotation of the hips visible in the sequence is the amount of twist rotation produced through catting. It occurred mainly as a reaction to the clockwise motions of the right leg, which moved toward the right, and then backward. (These actions of the right leg are subtle, but nevertheless visible in the sequence.) In part, the counterclockwise catting rotation of the hips was also a reaction to the clockwise rotation of the right arm. Without the catting, the twist rotation of this athlete would have been reduced by an amount equivalent to the approximately 45° of counterclockwise rotation visible in the sequence of Figure 21.

Some jumpers emphasize the twisting angular momentum more; others tend to emphasize the catting more. If not enough twisting angular momentum is generated during the takeoff phase, or if the athlete does not do enough catting in the air, the athlete will not twist enough in the air, which will make the body be in a tilted position at the peak of the jump, with the hip of the lead leg lower than the hip of the takeoff leg. This will put the hip of the lead leg (i.e., the low hip) in danger of hitting the bar.

There are other ways in which problems can occur in the twist rotation. If at the end of the takeoff phase an athlete is tilting backward too far, or is tilting too far toward the right (too far toward the left in the case of a jumper who takes off from the right foot), or if the lead leg is lowered too soon after takeoff, the twist rotation will be slower. This is due to interactions between the somersault and twist rotations that are too complex to explain here.

According to the previous discussion, a tilted position at the peak of the jump in which the hip of the lead leg is lower than the hip of the takeoff leg can be due to a variety of causes: an insufficient amount of twisting angular momentum; a much larger amount of forward than lateral somersaulting angular momentum; insufficient catting in the air; a backward tilted position of the body at the end of the

takeoff phase; a position that is too tilted toward the right at the end of the takeoff phase (toward the left in the case of jumpers taking off from the right foot); premature lowering of the lead leg soon after takeoff.

When this kind of problem occurs, it will be necessary to check the cause of the problem in each individual case, and then decide what would be the easiest way to correct it.

Control of airborne movements; computer simulation

We have seen that the c.m. path and the angular momentum of a high jumper are determined by the time the athlete leaves the ground. We have also seen that in spite of these restrictions on the freedom of the jumper, the athlete still has a certain degree of control over the movements of the body during the airborne phase.

Sometimes it is easy to predict in rough general terms how the actions of certain parts of the body during the airborne phase will affect the motions of the rest of the body, but it is difficult to judge through simple "eyeballing" whether the **amounts** of motion will be sufficient to achieve the desired results. Other times, particularly in complex three-dimensional airborne motions such as those involved in high jumping, it is not even possible to predict the **kinds** of motions that will be produced by actions of other parts of the body, let alone their amounts.

To help solve this problem, a method for the computer simulation of human airborne movements was developed (Dapena, 1981). In this method, we give the computer the path of the c.m. and the angular momentum of the body from an actual jump that was filmed or videotaped. We also give the computer the patterns of motion (angles) of all the body segments relative to the trunk during the entire airborne phase. The computer then calculates how the trunk has to move during the airborne phase to maintain the path of the c.m. and the angular momentum of the whole body the same as in the original jump. If we input to the computer the original patterns of motion of the segments (that is, the patterns of motion that occurred in the original

jump), the computer will generate a jump that will be practically identical to the original jump. But if we input to the computer altered patterns of motion of the segments, the computer will generate an altered jump. This is the jump that would have been produced if the high jumper had used the same run-up and takeoff as in the original jump, but then decided to change the motions of the limbs after taking off from the ground. Once the computer has generated the simulated jump, this jump can be shown using graphic representations just like any other jump.

With the simulation method, it is also possible to input to the computer an altered amount of angular momentum. This generates a simulated jump that shows how the athlete would have moved in the air if the run-up and takeoff had been changed to produce a different amount of angular momentum than in the original jump.

The computer simulation method just described can be used to test for viable alternatives in the airborne actions of high jumpers, and also to investigate the effects of different amounts of angular momentum.

SPECIFIC RECOMMENDATIONS FOR INDIVIDUAL ATHLETES

Jim DILLING

Jump 97 was Dilling's last successful clearance at the 2007 USATF Championships (2.27 m).

Based on Dilling's vertical velocity at takeoff in jump 97 ($v_{ZTO} = 4.40$ m/s), a technique of average quality would have included a final run-up speed of about 7.5 m/s and a c.m. height at the end of the run-up equal to about 47% of his own standing height. Dilling's actual c.m. height at the end of the run-up was similar to what might have been expected for a technique of average quality ($h_{TD} = 47.5\%$), but he was faster ($v_{HI} = 7.8$ m/s). The overall combination of run-up speed and c.m. height that Dilling used in jump 97 was reasonably good for a jumper capable of generating 4.40 m/s of vertical velocity.

The last step of Dilling's run-up was somewhat too long ($SL_1 = 2.05$ m, or 105% of his own standing height). This slightly long length of the last step of the run-up probably contributed to Dilling's somewhat large negative vertical velocity at the start of the takeoff phase ($v_{ZTD} = -0.6$ m/s). A large negative v_{ZTD} value is not advisable, because it requires the athlete to make an extra effort to stop the downward motion before producing the needed upward vertical velocity.

At the end of the run-up, Dilling planted the takeoff foot too parallel to the bar. Because of this, the angle between the longitudinal axis of the takeoff foot and the horizontal force received by the foot was too large ($e_3 = 33^\circ$). This would normally lead us to predict a risk of foot pronation, and injury to the ankle and foot. (See the section on "Orientation of the takeoff foot, and potential for ankle and foot injuries" in the main text of the report.) However, direct examination of the videos showed little or no visible pronation in any of Dilling's jumps. It is necessary to keep in mind that, due to our camera locations, it is harder to actually see pronation in jumpers who approach from the right side (like Dilling), so it is conceivable that he might be pronating without our noticing it, but we think this is unlikely.

Dilling started his arm preparations too many steps before the takeoff. Therefore, he spent too many steps running with the arms out of sync with the legs. To some extent, this may have limited his ability to run fast. But he did succeed in having his arms in good (i.e., low) positions at the start of the

takeoff phase. Then, his arm actions during the takeoff phase were strong ($AAT = 16.2$ mm/m). However, the action of his lead leg was weak ($LLA = 15.8$ mm/m), and therefore his overall combination of arm and lead leg actions was somewhat weak ($FLA = 32.1$ mm/m).

In jump 97, the backward lean of Dilling's trunk at the start of the takeoff phase was somewhat small ($BFTD = 79^\circ$). Then he rotated forward, and by the end of the takeoff his trunk was 2° beyond the vertical ($BFTO = 92^\circ$). In the view from the side, the trunk should be vertical (i.e., at 90°) at the end of the takeoff, so Dilling's overrotation probably produced a slight loss of lift. Dilling was able to generate a good amount of forward somersaulting angular momentum ($H_F = 80$). It would have been preferable for Dilling to have a greater amount of backward lean at the start of the takeoff phase, and then rotated only up to the vertical by the end of the takeoff. That way, he would have been able to generate the same amount of angular momentum without incurring any loss of lift.

Dilling's trunk had a good amount of lean toward the left at the start of the takeoff phase ($LRTD = 77^\circ$). Then, he rotated toward the right, but by the end of the takeoff he had not quite reached the vertical in the view from the back ($LRTO = 89^\circ$). In the view from the back, it's normal to go a few degrees past the vertical at the end of the takeoff. We consider it acceptable (indeed, desirable) to tilt up to 10° past the vertical at the end of the takeoff (in the view from the back) because we believe that this may be the best compromise between the generation of lift and the generation of rotation (angular momentum). Thus, Dilling's position at the end of the takeoff in jump 97 was too conservative. Because of this, the amount of lateral somersaulting angular momentum that he was able to generate was extremely small ($H_L = 35$). (Figure 18 shows the clearly the difference between Dilling's H_L values and those of the other high jumpers.)

Dilling's forward and lateral components of somersaulting angular momentum added up to a very small total amount of somersaulting angular momentum ($H_S = 90$).

Dilling's small amount of lateral somersaulting angular momentum produced two problems. The most important one was that it reduced his total amount of somersaulting angular momentum, which in turn slowed down the somersault rotation over the bar. But in addition it also produced a large

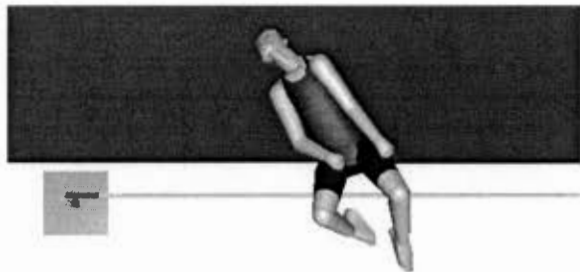

disproportion between his forward and lateral components of somersaulting angular momentum. This disproportion prevented Dilling's body from being perpendicular to the bar during the bar clearance. Instead, he was slanted, with his head much closer to the left standard than his legs. (See above.) This slanted position made the left knee reach the bar earlier than the right knee, and thus made it more difficult to avoid dislodging the bar with the legs.

The peak height reached by the c.m. in jump 97 was $h_{PK} = 2.36$ m. The "saturation graph" shows that in this jump Dilling could have cleared cleanly a bar set at about $h_{CLS} = 2.27$ m, and at $h_{CLA} = 2.28$ m if he had taken off slightly closer to the plane of the bar and the standards. In relation to the peak height of the c.m. (2.36 m), the 2.28 m clean clearance height indicated that his bar clearance was not very effective. This did not mean that Dilling did anything wrong in the air; in fact, his actions in the air were quite good. The lack of effectiveness of Dilling's bar clearance was the direct result of his very small total amount of somersaulting angular momentum, and therefore the result of the extremely small amount of lateral somersaulting angular momentum that he was able to generate during the takeoff.

We carried out several tests using computer simulation of the bar clearance. In these tests we kept the position at takeoff, the angular momentum and the path of the c.m. the same as in the original jump, but we made changes in the actions that Dilling made in the air. In these simulations, we were not able to improve on the effectiveness of the bar clearance that Dilling achieved in the original jump. This confirmed that the problems in Dilling's bar clearance were due to his angular momentum, and not to his actions in the air.

Recommendations

Dilling's combination of speed and height at the end of the run-up (7.8 m/s and 47.5%, respectively)

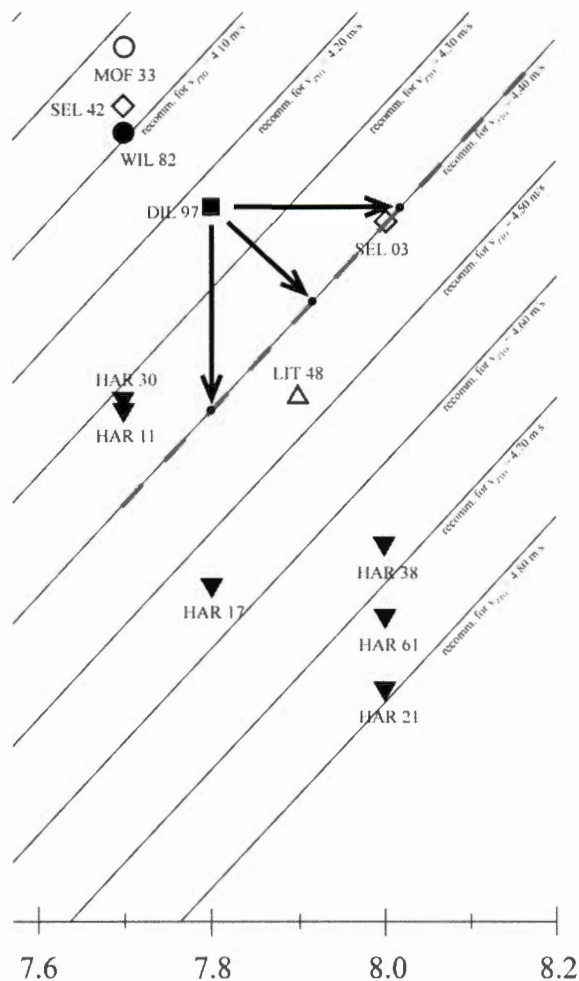

was reasonably good, better than average quality. However, for a truly high quality combination it would be advisable for Dilling to use a still slightly faster and/or lower run-up. In terms of Figure 3, Dilling's point should be moved to the diagonal line recommended for $v_{ZTO} = 4.40$ m/s. (See the graph above.) Possible combinations could be 8.0 m/s and 47.5%, or 7.9 m/s and 46.5%, or 7.8 m/s and 46%, as shown by the three arrows in the graph. (See Appendix 2 for exercises that will help to produce fast and low conditions at the end of the run-up.)

(Standard caution when increasing the run-up speed and/or lowering the c.m. height at the end of the run-up: The use of a faster and/or lower run-up will put a greater stress on the takeoff leg, and thus it may increase the risk of injury if the leg is not strong enough. Therefore, it is always important to use caution in the adoption of a faster and/or lower run-up. If the desired change is very large, it would be advisable to make it gradually, over a period of time. In all cases, it may be wise to further strengthen the takeoff leg, so that it can

withstand the increased force of the impact produced when the takeoff leg is planted.)

A small problem in Dilling's technique was the somewhat long length of the last step of his run-up. To correct this, he should try to increase the tempo of the last two foot landings, i.e., he should try to plant the left foot on the ground almost immediately after he plants the right foot. By increasing the tempo of the last two foot landings, Dilling will reduce the length of the last step of the run-up, but more importantly, he will reduce the time that he spends in the air during that step. This will prevent him from accumulating too much downward (negative) vertical velocity in the air, so that he does not have an excessively large downward vertical velocity when he plants the left foot on the ground to start the takeoff phase.

In the view from the back, Dilling had a good lean toward the left at the start of the takeoff phase, but then he did not allow his trunk to rotate enough toward the right by the end of the takeoff. This is probably the most important problem in Dilling's technique. He needs to allow his trunk to rotate much further toward the right, to a position up to 10° beyond the vertical in the view from the back at the end of the takeoff phase. This will allow him to generate a larger amount of lateral somersaulting angular momentum, which in turn will lead to a larger total amount of somersaulting angular momentum as well as better proportions between the forward and lateral components of somersaulting angular momentum. This will produce a better somersault rotation over the bar, and will thus improve the effectiveness of Dilling's bar clearance.

A much smaller problem is Dilling's somewhat small amount of backward lean at the start of the takeoff phase. He should thrust his hips a little bit further forward in the very last step of the run-up. This will give his trunk a larger amount of backward lean at the start of the takeoff phase. Then, he should allow his trunk to rotate forward during the takeoff phase, but only up to the vertical by the end of the takeoff. This should produce the same amount of forward somersaulting angular momentum as in jump 97, while avoiding any loss of lift that might have been produced through excessive forward lean at the end of the takeoff.

While Dilling's arm actions during the takeoff phase were good, the action of his lead leg was not very strong. This is another problem that is relatively minor, because to a great extent the strong actions of the arms partly compensate for the weakness of the

lead leg. But if Dilling lifted the knee of his right knee higher at the end of the takeoff, he would be able to generate a little bit more lift during the takeoff phase.

In summary, the most serious problem in Dilling's technique is probably his very small amount of lateral somersaulting angular momentum, which has an important detrimental effect on the effectiveness of his bar clearance. This needs to be corrected by allowing the trunk to rotate further toward the right by the end of the takeoff phase. Of lesser importance are the slightly excessive length of the last step of his run-up, his somewhat insufficient amount of backward lean at the start of the takeoff phase, and the weakness of his lead leg action during the takeoff phase.

DILLING #97 062407 2.27 M CLEARANCE

RUN-UP

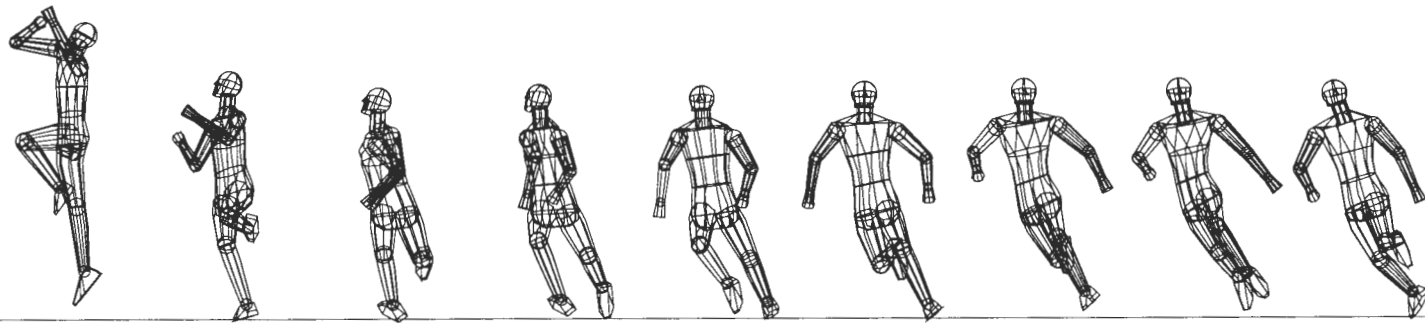
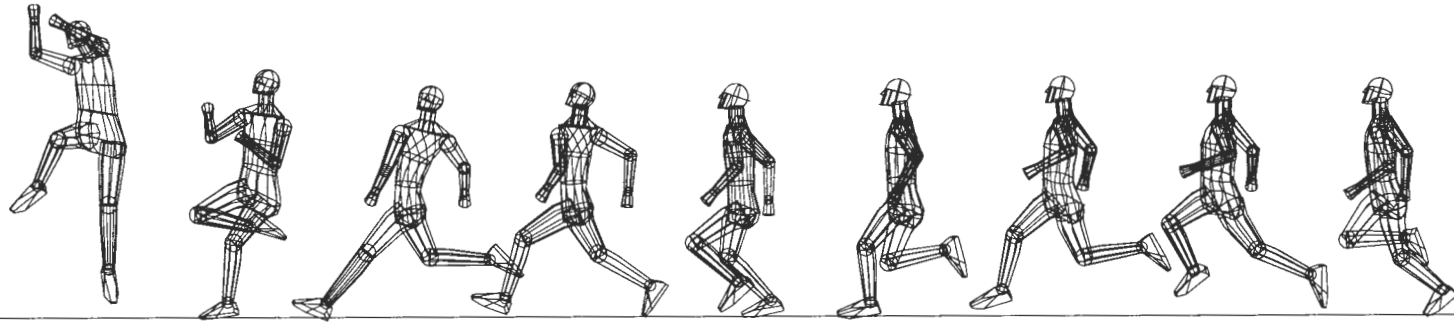

10.20

10.10

10.00

9.94

9.88

9.82

9.76

9.70

9.64

DILLING #97 062407 2.27 M CLEARANCE

TAKEOFF PHASE

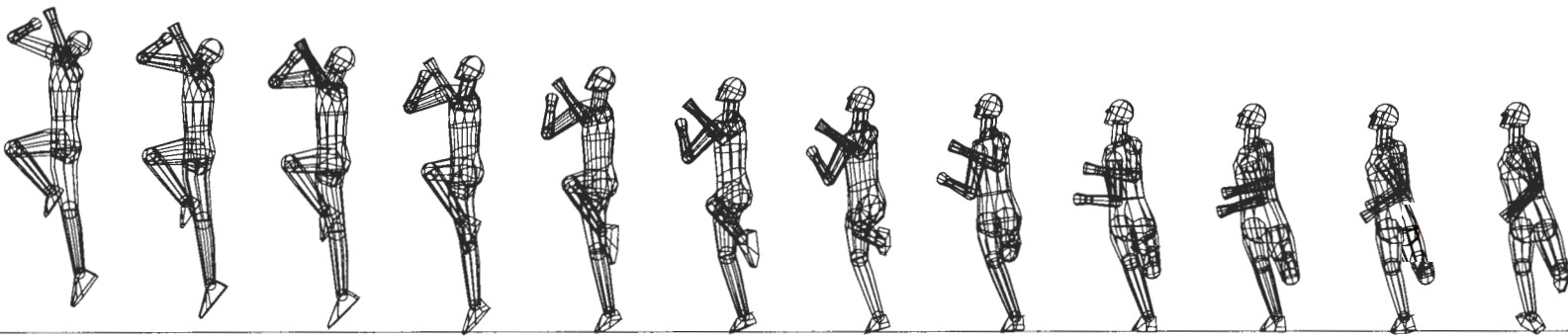
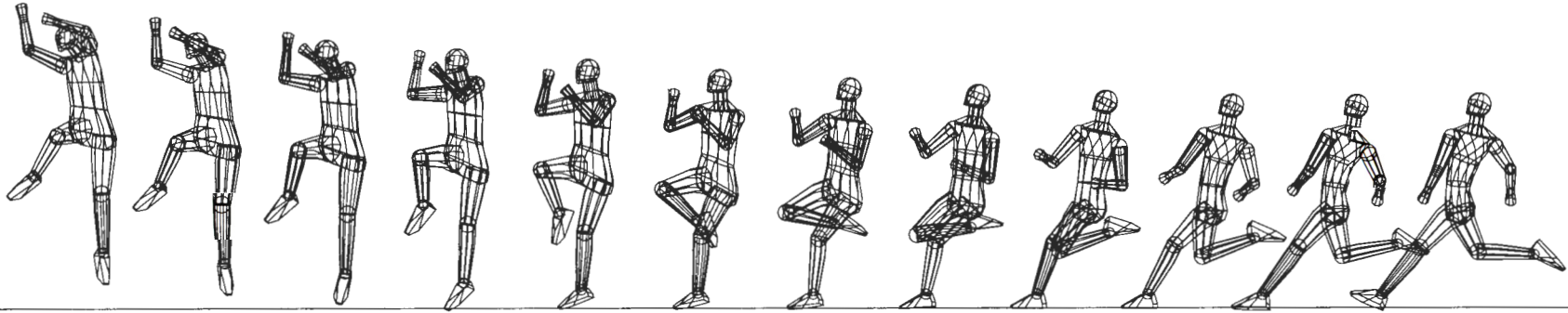

10.22

10.20

10.18

10.16

10.14

10.12

10.10

10.08

10.06

10.04

10.02

10.00

DILLING #97 062407 2.27 M CLEARANCE

BAR CLEARANCE

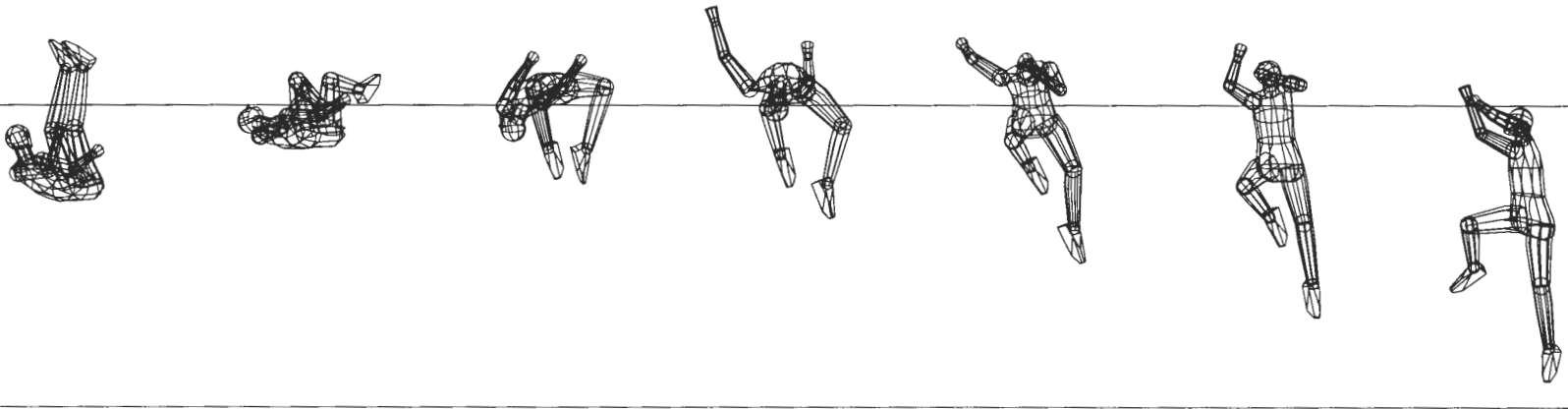
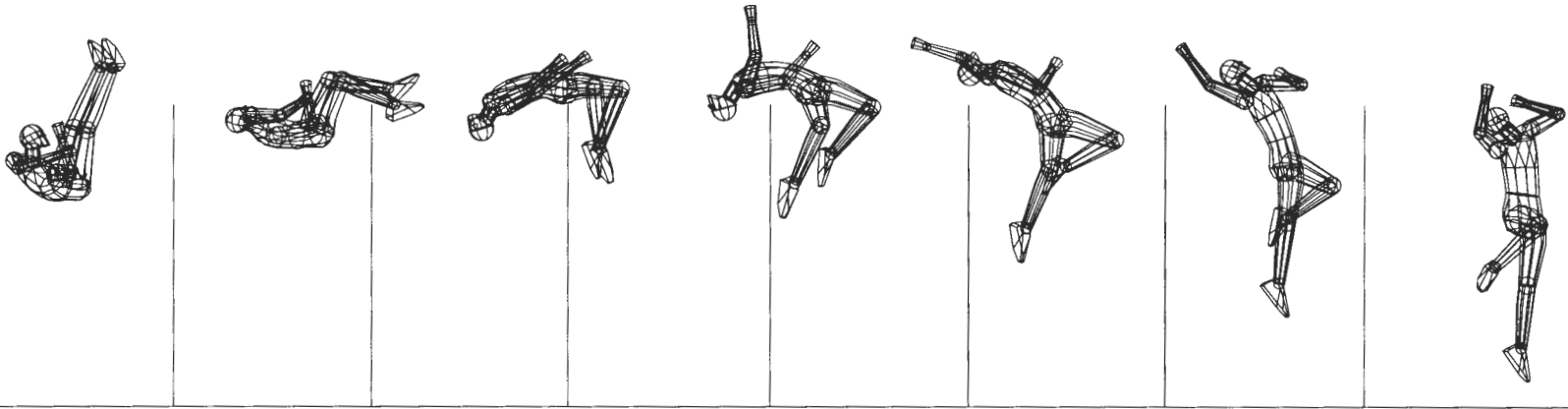

10.94

10.82

10.70

10.58

10.46

10.34

10.22

C.M. HEIGHT VS TIME

9.40

9.60

9.80

10.00

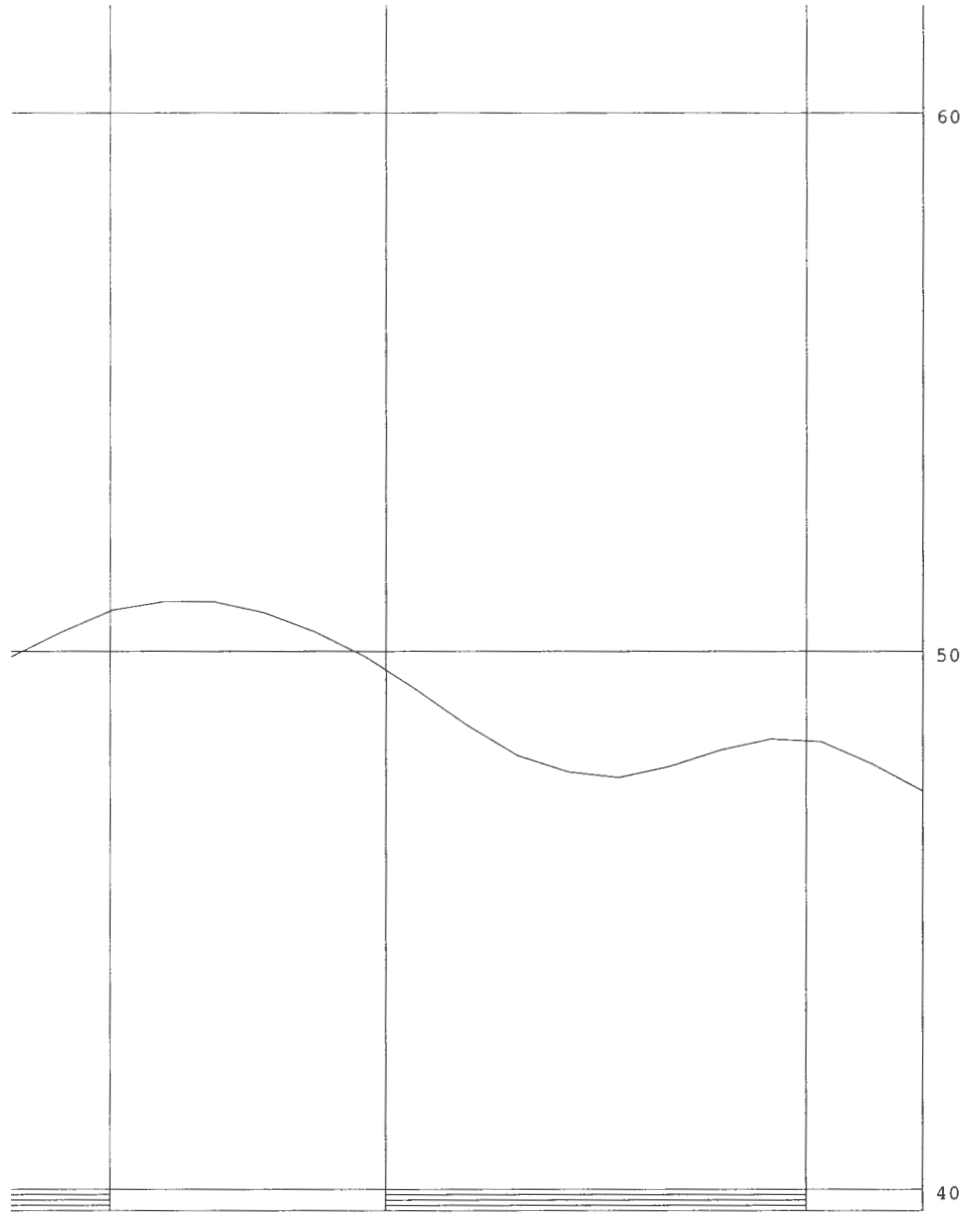

DILLING #97 062407 2.27 M CLEARANCE

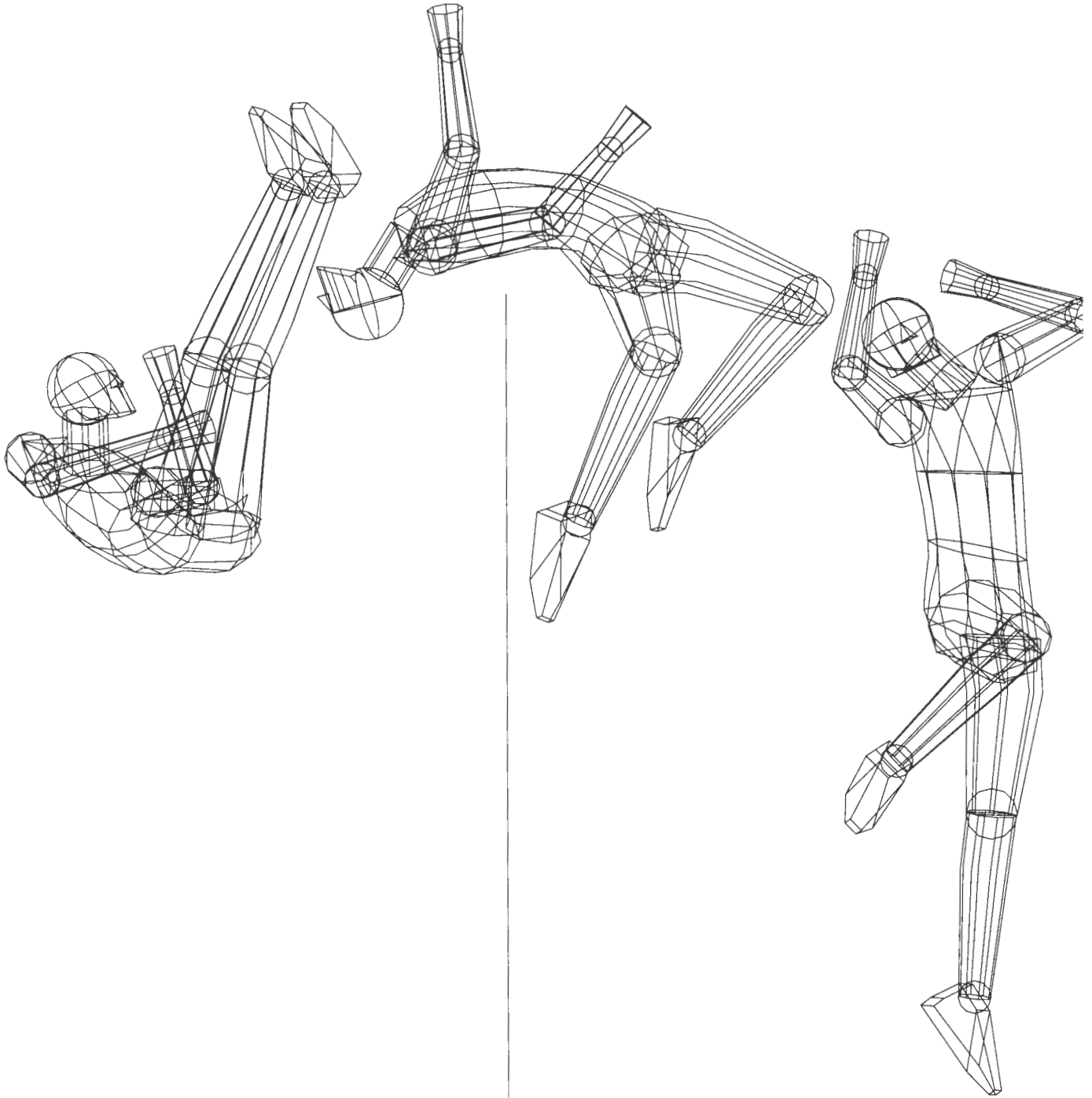

DILLING #97 062407 2.27 M CLEARANCE

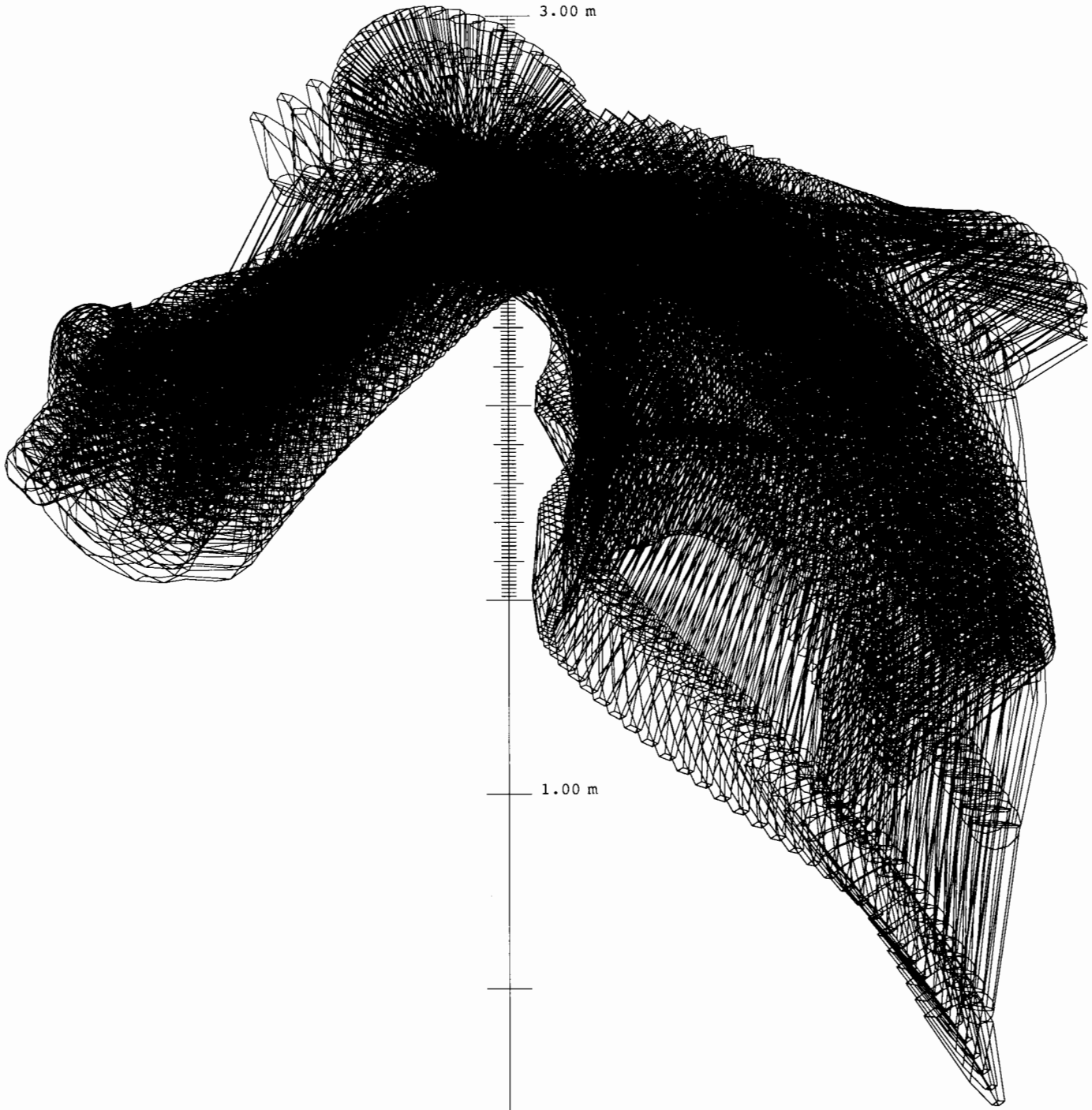

DILLING #97 062407 2.27 M CLEARANCE

Tora HARRIS

Jump 61 was Harris' last successful clearance at the 2007 USATF Championships (2.21 m).

Based on Harris' vertical velocity at takeoff in jump 61 ($v_{ZTO} = 4.30$ m/s), a technique of average quality would have included a final run-up speed of about 7.4 m/s and a c.m. height at the start of the takeoff phase equal to about 47% of his own standing height. Harris' actual speed at the end of the run-up ($v_{HI} = 8.0$ m/s) was much faster than what would be expected for a technique of average quality, and his c.m. at the end of the run-up was in a much lower position ($h_{TD} = 44.5\%$) than what would be expected. Overall, the combination of run-up speed and c.m. height that Harris used in jump 61 was extremely demanding –maybe too demanding if he was not in peak physical condition.

At the end of the run-up, Harris planted the takeoff foot too parallel to the bar. Because of this, the angle between the longitudinal axis of the takeoff foot and the horizontal force received by the foot was somewhat too large ($e_3 = 26^\circ$). This was actually a very good improvement in comparison with any of his previous analyzed jumps, but still it would normally lead us to predict some risk of foot pronation, and injury to the ankle and foot. (See the section on “Orientation of the takeoff foot, and potential for ankle and foot injuries” in the main text of the report.) However, direct examination of the videos showed little or no visible pronation in any of Harris' jumps. It is necessary to keep in mind that, due to our camera locations, it is harder to actually see pronation in jumpers who approach from the right side (like Harris), so it is conceivable that he might be pronating without our noticing it, but we think this is highly unlikely.

Harris' arm actions during the takeoff phase were strong (AAT = 16.3 mm/m), a good improvement relative to 2006. The action of his lead leg was weak (LLA = 12.9 mm/m), although it was better than in any of his previous analyzed jumps. The overall combination of arm and lead leg actions was weak (FLA = 29.3 mm/m), although it was better than in most of his previous analyzed jumps. Normally, we would consider weakness in the free-limb actions a problem in a jumper's technique. However, Harris' run-up was so fast and so low that it put a tremendous amount of stress on the takeoff leg. The use of very strong free-limb actions during the takeoff phase in addition to such conditions at the end of the run-up might have produced the collapse of the takeoff leg. Therefore, Harris' free-limb actions may have been

adequate for his needs, and possibly even too strong, given the extremely demanding conditions produced by his tremendously fast and low run-up.

Harris' trunk had a moderate backward lean at the start of the takeoff phase (BFTD = 76°). Then, he rotated forward during the takeoff phase, but at the end of the takeoff he was still somewhat short of the vertical in a view from the side (BFTO = 87°). The amount of forward somersaulting angular momentum that Harris was able to generate was somewhat small ($H_F = 75$).

Harris' trunk had a very good lean toward the left at the start of the takeoff phase (LRTD = 74°). Then he rotated toward the right, and at the end of the takeoff he was 7° past the vertical in a view from the back (LRTO = 97°). In the view from the back, it's normal to be up to 10° past the vertical at the end of the takeoff. Therefore, Harris' position at the end of the takeoff in jump 61 was very good. His good positions at the start and at the end of the takeoff phase enabled him to generate a large total amount of lateral somersaulting angular momentum ($H_L = 95$).

Harris' forward and lateral components of somersaulting angular momentum added up to a large total amount of somersaulting angular momentum ($H_S = 120$).

Harris' c.m. reached a maximum height $h_{PK} = 2.28$ m in jump 61. The “saturation graph” shows that in this jump he could have cleared cleanly a bar set at about $h_{CLS} = 2.24$ m, and at $h_{CLA} = 2.26$ m if he had taken off between 5 and 10 cm closer to the plane of the bar and the standards. In relation to the peak height of the c.m. (2.28 m), the 2.26 m clean clearance height indicated a very effective bar clearance.

Recommendations

All aspects of Harris' technique were quite good. The orientation of the takeoff foot does not seem to be a problem anymore now that we can observe it more accurately with high-definition video.

Harris' combination of speed and c.m. height at the end of the run-up was extremely good. He should not go any faster or lower than in jump 61. We also suspect that he should not go quite so fast nor so low unless he is in perfect physical condition.

The weakness of Harris' arm and lead leg actions might superficially seem to be a problem in his

technique. However, as explained before, we believe that Harris' arm and lead leg actions may actually have been too strong, given how fast and how low he was at the end of the run-up.

Harris' leans backward and toward the left at the start of the takeoff phase and at the end of the takeoff phase were all good in jump 61. This aspect of his technique needs no changes.

Harris' bar clearance is unorthodox, as usual, with a "sitting" body configuration on the way up to the bar (see the sequence of the bar clearance at $t = 10.34$ s and $t = 10.46$ s) and a somewhat tilted position near the peak of the jump, with the right hip lower than the left hip (see the sequence of the bar clearance at $t = 10.70$ s). However, this technique works well with Harris' conditions at the end of the takeoff. The technique is very effective for Harris, allowing him to clear cleanly a bar set only 2 cm lower than the peak height reached by his c.m. Therefore, we advise him to make no changes in it.

One might then ask why Harris did not jump nearly as high in the 2007 competition as in the 2006 competition. A key element was his much smaller amount of vertical velocity at the end of the takeoff, $v_{ZTO} = 4.50$ m/s in 2006 but 4.30 m/s in jump 61 from 2007, which produced a peak c.m. height of 2.38 m in 2006 but 2.28 m in jump 61 from 2007. We do not know what caused this deterioration. Technique did not seem to be the problem. We suspect that Harris' physical condition was not good on the day of the 2007 meet, or that he was simply unable to coordinate his muscular efforts properly during the takeoff phase –the classical "bad day" syndrome that all high jumpers experience at one meet or another. Harris may have compounded the problem by sticking to an extremely demanding combination of very fast speed and very low height at the end of the run-up. If the physical condition of the athlete is not at its peak, it is better to back off slightly from making extreme demands on the takeoff leg, because the weakened takeoff leg will actually perform worse with a "better" (i.e., more demanding) combination of run-up speed and height.

Another factor that affected Harris' performance at the 2007 meet was that, when the bar was raised to 2.24 m he was unable to repeat the jump that he had executed at the 2.21 m height. His three attempts at 2.24 m were inferior to his jump at 2.21 m, which would have allowed him to clear the 2.24 m bar, and possibly (with a slight brush) even the 2.27 m bar.

HARRIS #61 062407 2.21 M CLEARANCE

RUN-UP

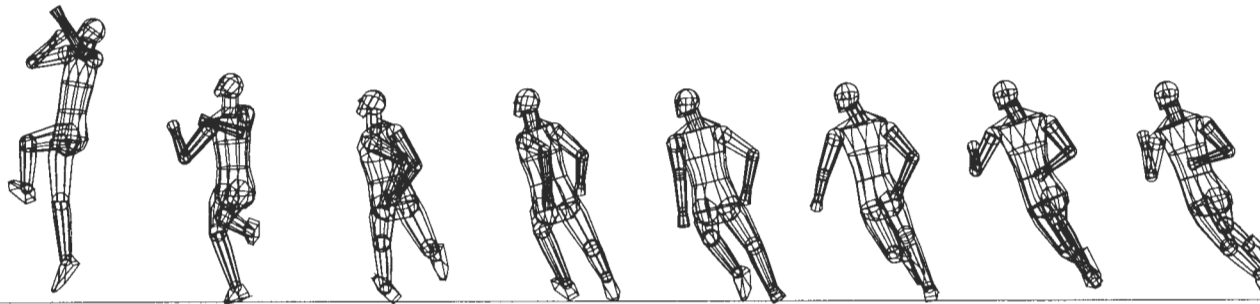
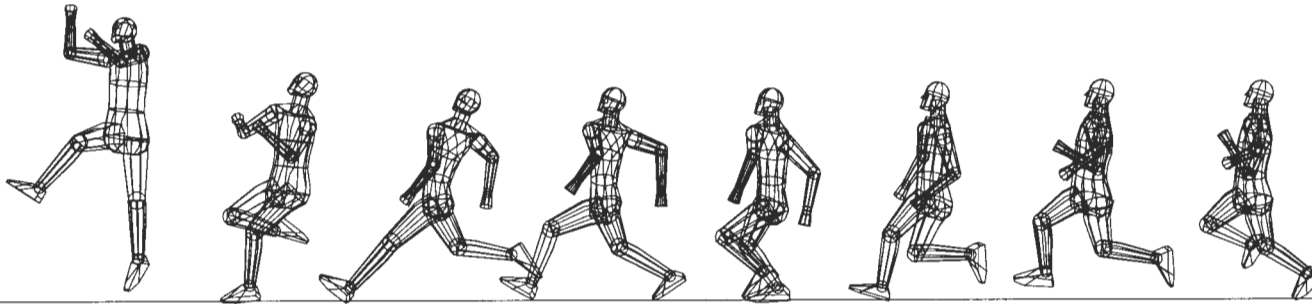

10.20

10.10

10.00

9.94

9.88

9.82

9.76

9.70

HARRIS #61 062407 2.21 M CLEARANCE

TAKEOFF PHASE

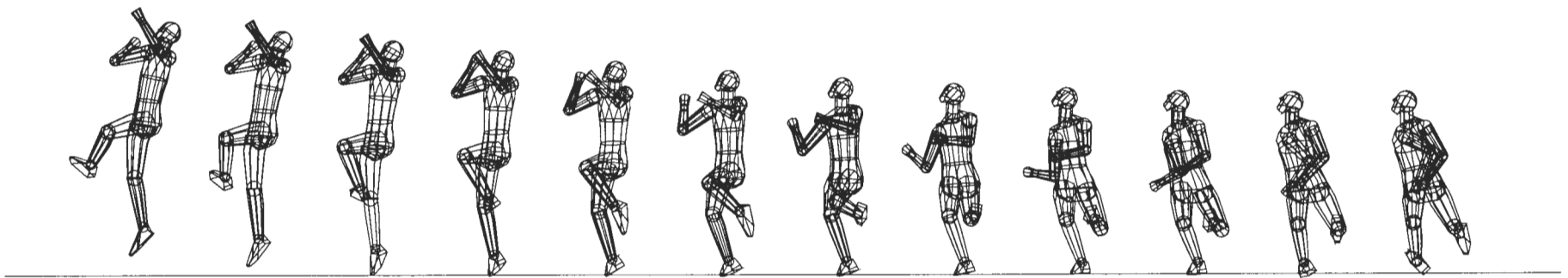
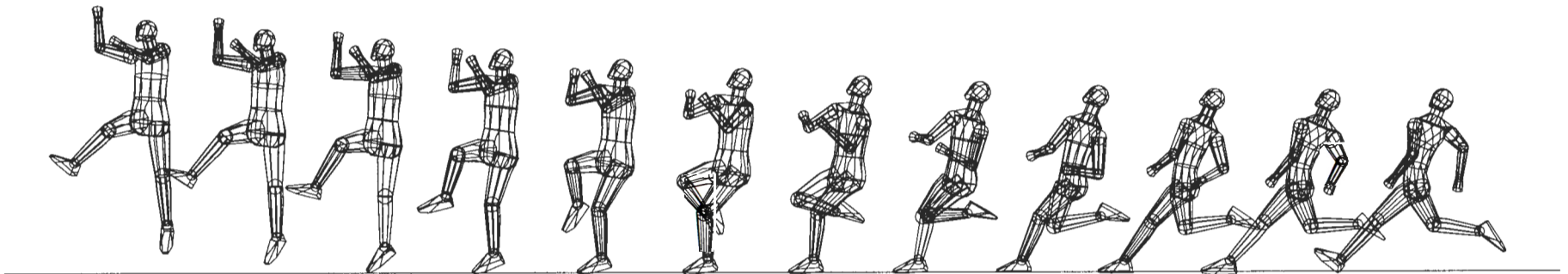

10.22

10.20

10.18

10.16

10.14

10.12

10.10

10.08

10.06

10.04

10.02

10.00

HARRIS #61 062407 2.21 M CLEARANCE

BAR CLEARANCE

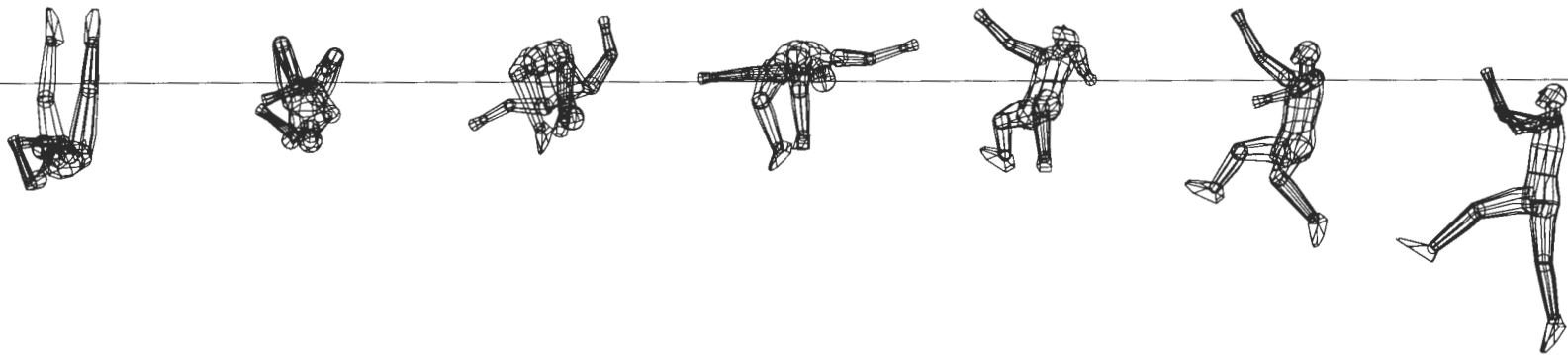
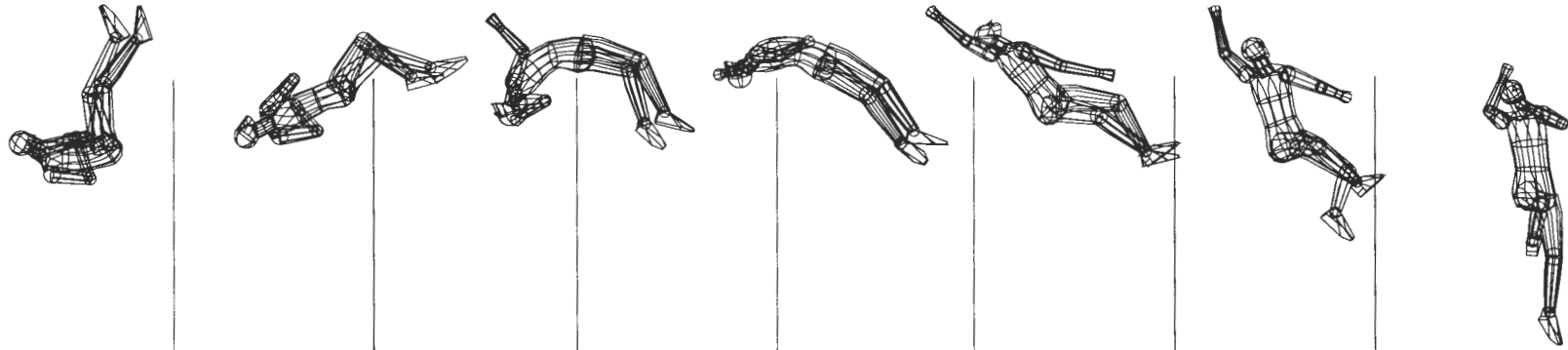

10.94

10.82

10.70

10.58

10.46

10.34

10.22

C.M. HEIGHT VS TIME

9.40

9.60

9.80

10.00

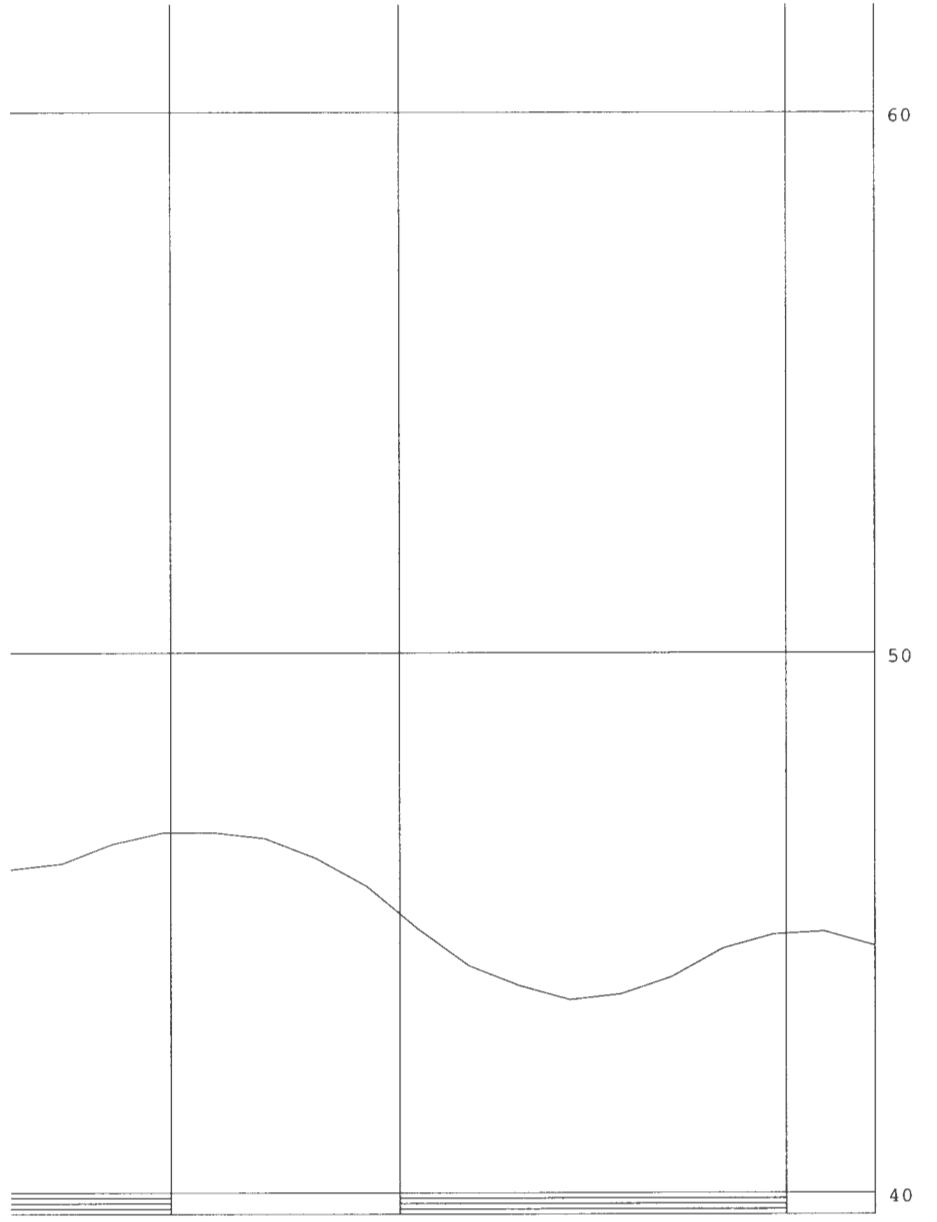

HARRIS #61 062407 2.21 M CLEARANCE

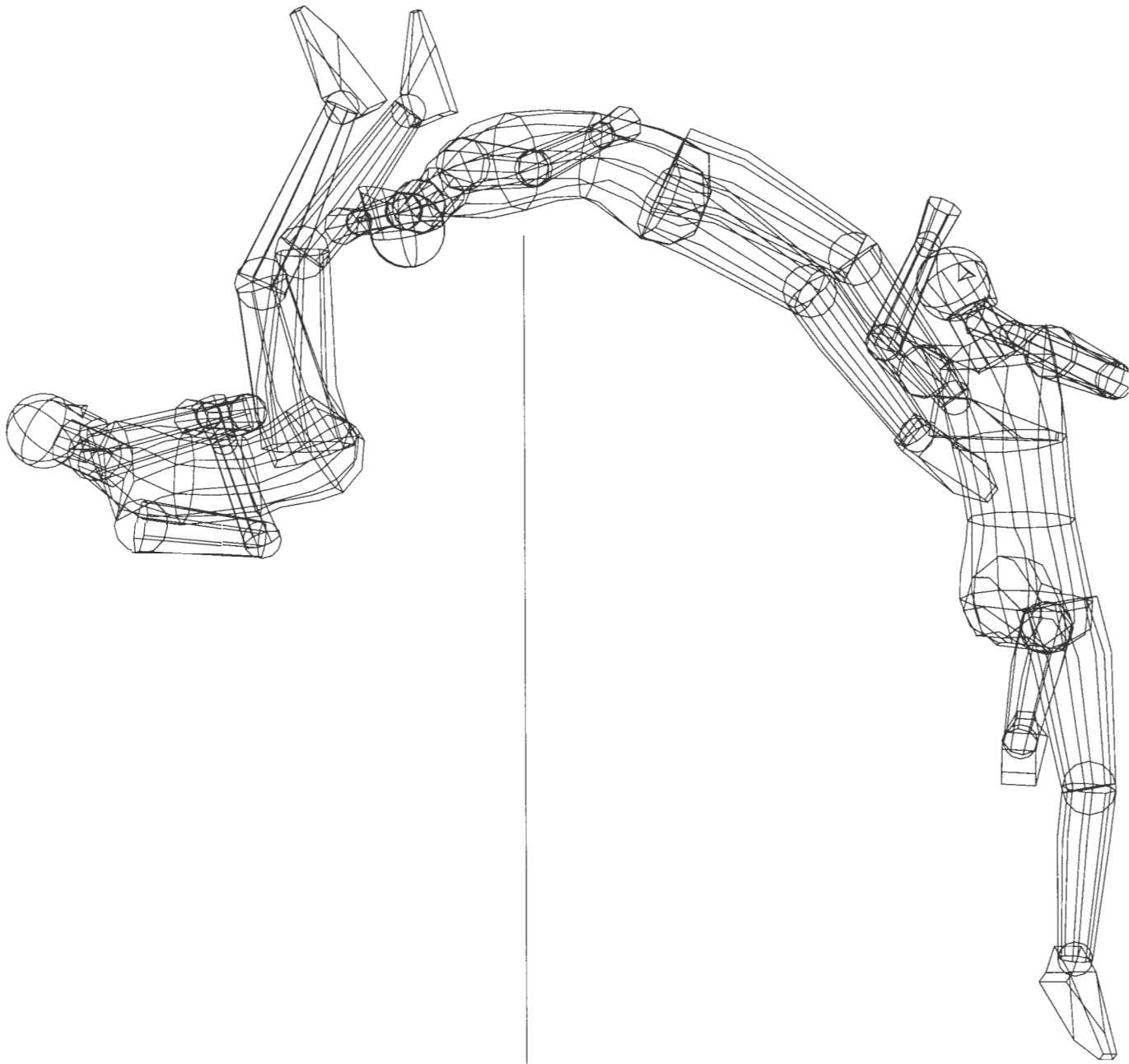

HARRIS #61 062407 2.21 M CLEARANCE

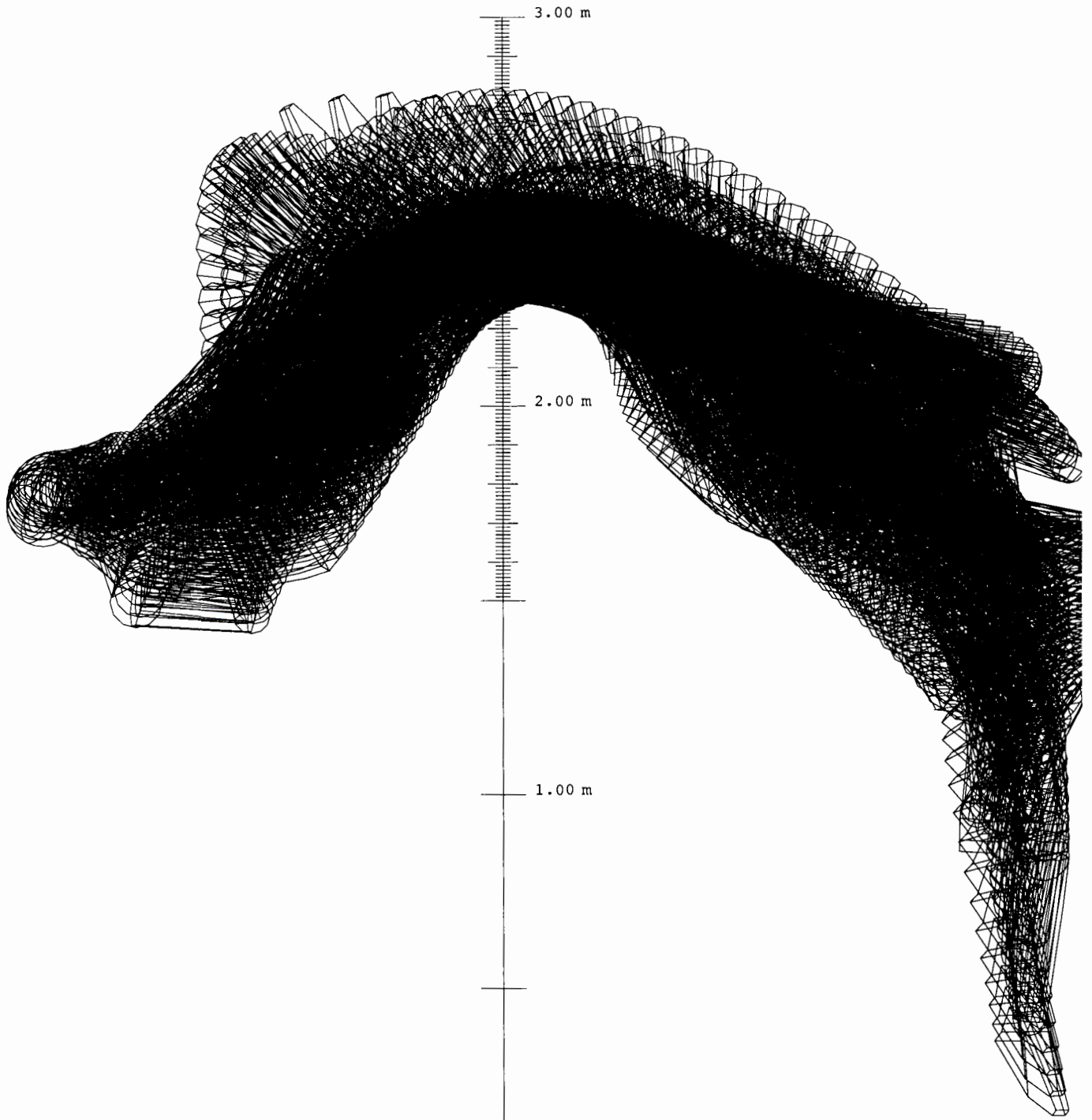

HARRIS #61 062407 2.21 M CLEARANCE

Eugene HUTCHINSON

Jump 72 was Hutchinson's last successful clearance at the 2007 USATF Championships (2.21 m).

Based on Hutchinson's vertical velocity at takeoff in jump 72 ($v_{ZTO} = 4.30$ m/s), a technique of average quality would have included a final run-up speed of about 7.4 m/s and a c.m. height at the start of the takeoff phase equal to about 47% of his own standing height. Hutchinson had a slower speed at the end of the run-up ($v_{HI} = 7.2$ m/s) than what would be expected for a technique of average quality, but his c.m. at the end of the run-up was also in a much lower position ($h_{TD} = 43.5\%$) than what would be expected. Overall, the combination of run-up speed and c.m. height that Hutchinson used in jump 72 was good.

The technique that Hutchinson used for getting into position in the last steps of the run-up was similar to the one used by athlete B of Appendix 1 (although less extreme). This was not good. Hutchinson's c.m. was in a moderately low position two steps before the takeoff phase. After he pushed off with his left foot into the next-to-last step, his c.m. reached a height of about 50% of his own standing height—in the pages of computer graphics that follow these comments, see Hutchinson's graph of "c.g. height vs time" at about $t = 9.68$ s. Then, Hutchinson lowered his c.m. to a much lower position. For this, he simply did not stop the drop completely at any time during the period of support over the right foot ($t = 9.76 - 9.97$ s). When the right foot left the ground at $t = 9.97$ s, Hutchinson was in a lower position than in the previous step, but the c.m. was not going up at this time: It was still dropping. Then, the speed of dropping became still larger in the final non-support phase of the run-up (from $t = 9.97$ s to $t = 10.00$ s). By the time that Hutchinson planted the left foot on the ground to start the takeoff phase, his c.m. was dropping at a somewhat large speed ($v_{ZTD} = -0.5$ m/s), and this was not good for the takeoff phase of the jump. A large negative v_{ZTD} value is not advisable, because it requires the athlete to make an extra effort to stop the downward motion before producing the needed upward vertical velocity. Another factor that influenced Hutchinson's rather large negative vertical velocity at the start of the takeoff phase was the long length of his last step ($SL_1 = 2.12$ m, or 112% of his own standing height).

At the end of the run-up, Hutchinson planted the takeoff foot at a very safe angle ($e_3 = 14^\circ$), and direct

examination of the videos showed no visible pronation in any of Hutchinson's jumps. This was all very good.

Hutchinson's arm actions during the takeoff phase were very strong (AAT = 25.3 mm/m). The action of his lead leg was also strong (LLA = 25.5 mm/m). Not surprisingly, the overall combination of arm and lead leg actions was very strong (FLA = 50.8 mm/m). This was all excellent

Hutchinson's trunk had a good backward lean at the start of the takeoff phase (BFTD = 75°). Then, he rotated forward during the takeoff phase, and at the end of the takeoff he was slightly beyond the vertical in a view from the side (BFTO = 92°). This slightly excessive forward lean at the end of the takeoff probably made him lose a little bit of lift. In spite of the large amount of forward rotation that Hutchinson went through during the takeoff phase, the amount of forward somersaulting angular momentum that he was able to generate during the takeoff phase was small ($H_F = 60$). This was probably due to his strong free-limb actions, which are good for generating lift but can interfere with the generation of forward somersaulting angular momentum. (See the section on "Angular momentum" in the main text of the report.)

Hutchinson's trunk had almost no lean toward the left at the start of the takeoff phase (LRTD = 87° ; vertical would have been 90°). Then he rotated toward the right, and at the end of the takeoff his trunk was 12° past the vertical in a view from the back (LRTO = 102°). In the view from the back, it's normal to go a few degrees past the vertical at the end of the takeoff. We consider it acceptable (indeed, desirable) to tilt up to 10° past the vertical at the end of the takeoff phase (in the view from the back) because we believe that this may be the best compromise between the generation of lift and the generation of rotation (angular momentum). But Hutchinson was 2° beyond the allowable limit for tilt at the end of the takeoff, and this may have cost him some additional lift. As in the forward rotation, Hutchinson's overrotation toward the right during the takeoff phase did not allow him to produce an adequate amount of angular momentum: His lateral somersaulting angular momentum was very small ($H_L = 70$). This was due to his almost complete lack of lean toward the left at the start of the takeoff phase.

Not surprisingly, Hutchinson's forward and lateral components of somersaulting angular

momentum added up to a very small total amount of somersaulting angular momentum ($H_S = 90$).

Hutchinson's c.m. reached a maximum height $h_{PK} = 2.27$ m in jump 72. The "saturation graph" shows that in this jump Hutchinson could have cleared cleanly a bar set at about $h_{CLS} = 2.21$ m, and at $h_{CLA} = 2.22$ m if he had taken off slightly farther from the plane of the bar and the standards. In relation to the peak height of the c.m. (2.27 m), the 2.22 m clean clearance height indicated that Hutchinson's bar clearance in jump 72 was reasonably effective. Considering that his angular momentum was very small, this indicated that his actions in the air were very good.

Recommendations

Most aspects of Hutchinson's technique were quite good. His main technique problem was in the bar clearance. Although we classify his bar clearance as "reasonably effective", this is not the same as saying that it was satisfactory: It wasn't. Hutchinson's bar clearance can be made much more effective than it was in jump 72. The solution will require the generation of a larger total amount of somersaulting angular momentum.

Hutchinson's forward component of somersaulting angular momentum was small. The reason for this was that it is difficult to generate a lot of forward somersaulting angular momentum when the athlete uses very intense arm and lead leg actions during the takeoff phase. Weakening the arm and lead leg actions during the takeoff phase would indeed help to increase the forward somersaulting angular momentum, but this would come at the cost of quite a bit of lift. Therefore this is not an advisable way to increase the angular momentum. Hutchinson should retain his current very good arm and lead leg actions during the takeoff phase, even if this limits the generation of forward somersaulting angular momentum. The solution to the angular momentum problem will need to come through the lateral component of somersaulting angular momentum, as we will see next.

The reason why Hutchinson was not able to generate a good amount of lateral somersaulting angular momentum (and therefore the main reason for the mediocre effectiveness of his bar clearance) was that he did not have enough lean toward the left at the start of the takeoff phase. (See the view from the back at $t = 10.00$ s in his run-up or takeoff sequences, and compare it with those of Harris, Nieto or Shunk.) In turn, the reason for this insufficient

lean toward the left was that Hutchinson's run-up was not curved enough: It was too straight. To acquire the necessary amount of lean toward the left at the end of the run-up, he will need to tighten the run-up curve, i.e., to use a curve with a shorter radius. See Appendix 4 for more information on how to change the shape of the run-up curve.

Also, having the appropriate amount of curvature in the run-up does not guarantee that the athlete will lean properly. The back view of Hutchinson at $t = 9.82/9.88$ s shows that his trunk stayed upright while the legs jutted out toward the right. This was not good. It is important to lean with the entire body, and not only with the legs.

Once Hutchinson has managed to get the appropriate amount of lean toward the left at the start of the takeoff phase (by using a shorter curve radius and by leaning with the entire body), he will be able to rotate toward the right through a very large angle during the takeoff phase, to a position up to 10° (but no more than that) beyond the vertical by the end of the takeoff. By doing this, he will be able to generate a larger amount of lateral somersaulting angular momentum. This will increase his total amount of somersaulting angular momentum, which in turn will improve the effectiveness of his bar clearance: With the same peak height of the c.m., he will be able to clear a bar set at a higher height.

A rather small problem in Hutchinson's technique was that he had a somewhat too large downward vertical velocity at the time that the left foot was planted on the ground to start the takeoff phase. To eliminate this problem, Hutchinson would first need to be already at a very low height two steps before takeoff. Then he would need to travel rather flat in those final two steps, neither raising nor lowering his hips. Then, in the last step of the run-up he should not lift his left foot as high as he did in jump 72 (see the side view at $t = 9.94$ s), and he should try to increase the tempo of the last two foot landings, i.e., he should try to plant the left foot on the ground almost immediately after he plants the right foot. By increasing the tempo of the last two foot landings, Hutchinson should be able to reduce the length of the last step of the run-up, but more importantly, he will reduce the time that he spends in the air during that step. This will prevent him from accumulating too much downward (negative) vertical velocity in the air, so that he does not have an excessively large downward vertical velocity when he plants the left foot on the ground to start the takeoff phase.

Other than the changes described above for the run-up curve and for the increase of the tempo of the last two footfalls of the run-up, we propose no other changes for Hutchinson's technique. His run-up was of the slow-but-very-low variety, which is a perfectly valid option. His arm and lead leg actions were very good, and so was the safe orientation of his takeoff foot. Except for the insufficient curvature of Hutchinson's run-up curve (and the problems that it produced in the bar clearance), and to a lesser extent his excessively long last step, his technique was overall very sound.

HUTCHINSON #72 062407 2.21 M CLEARANCE

RUN-UP

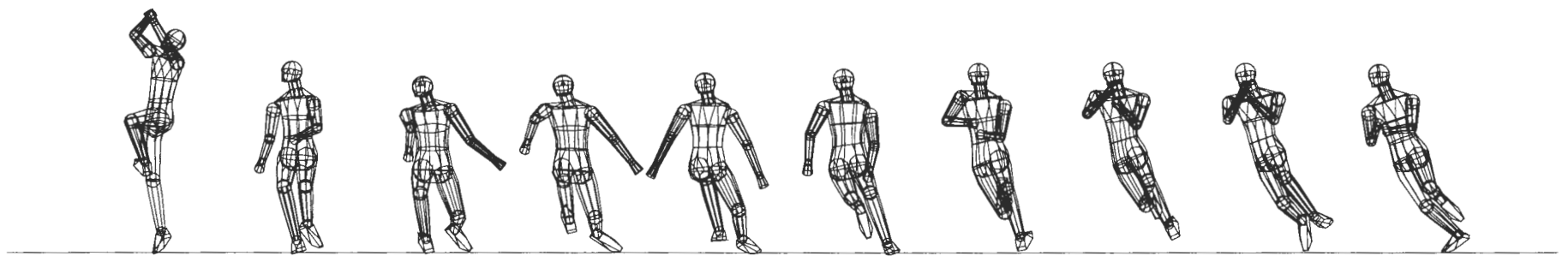
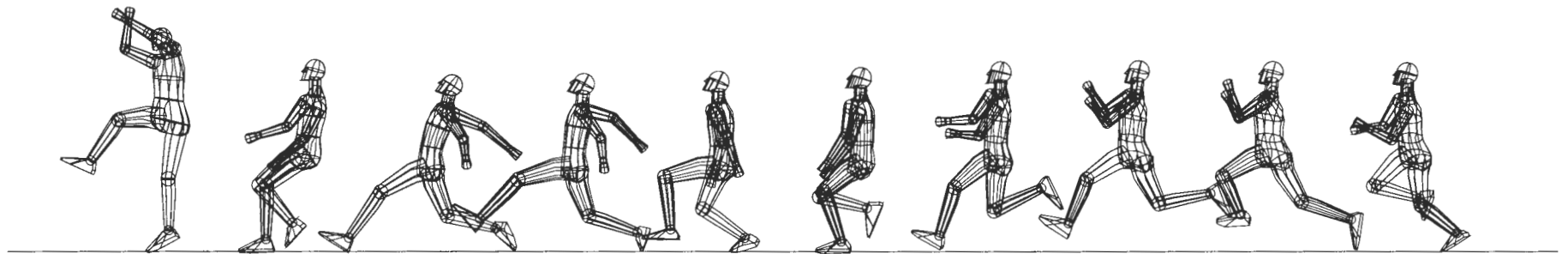

10.20

10.10

10.00

9.94

9.88

9.82

9.76

9.70

9.64

9.58

HUTCHINSON #72 062407 2.21 M CLEARANCE

TAKEOFF PHASE

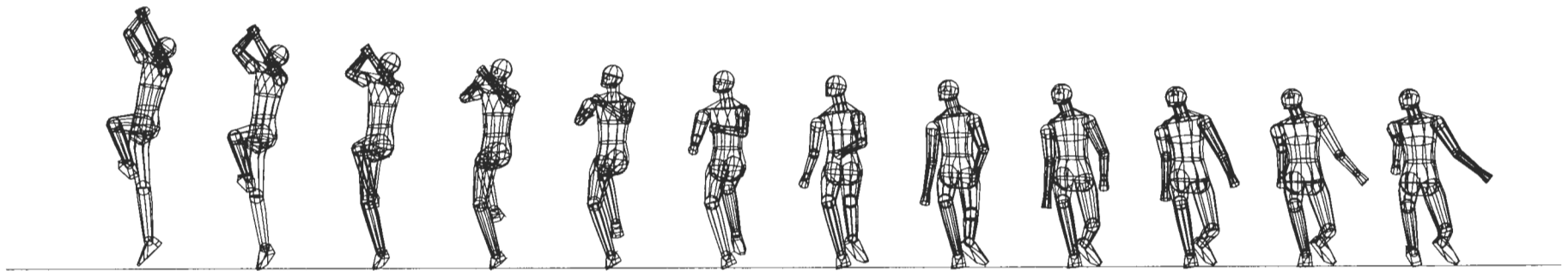
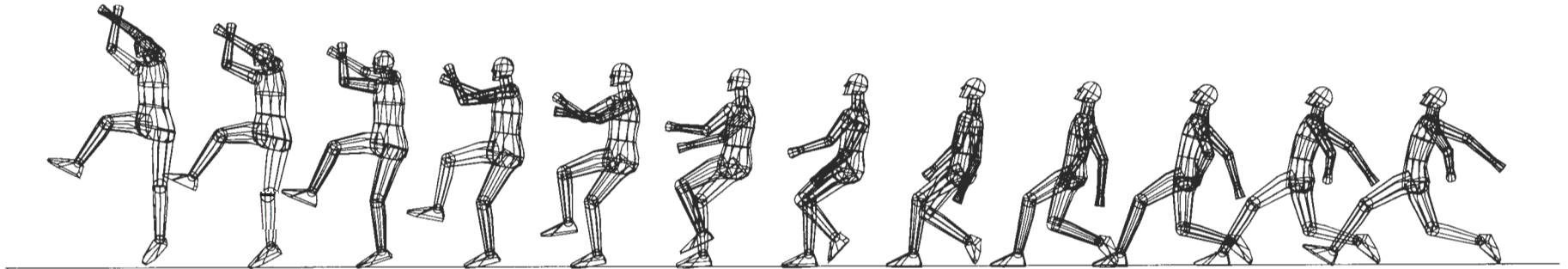

10.22

10.20

10.18

10.16

10.14

10.12

10.10

10.08

10.06

10.04

10.02

10.00

HUTCHINSON #72 062407 2.21 M CLEARANCE

BAR CLEARANCE

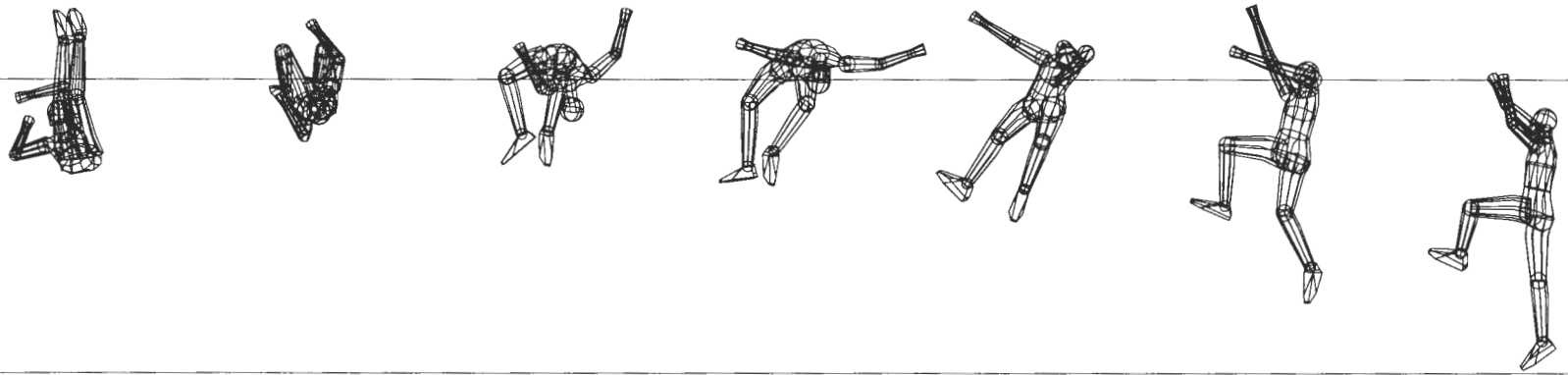
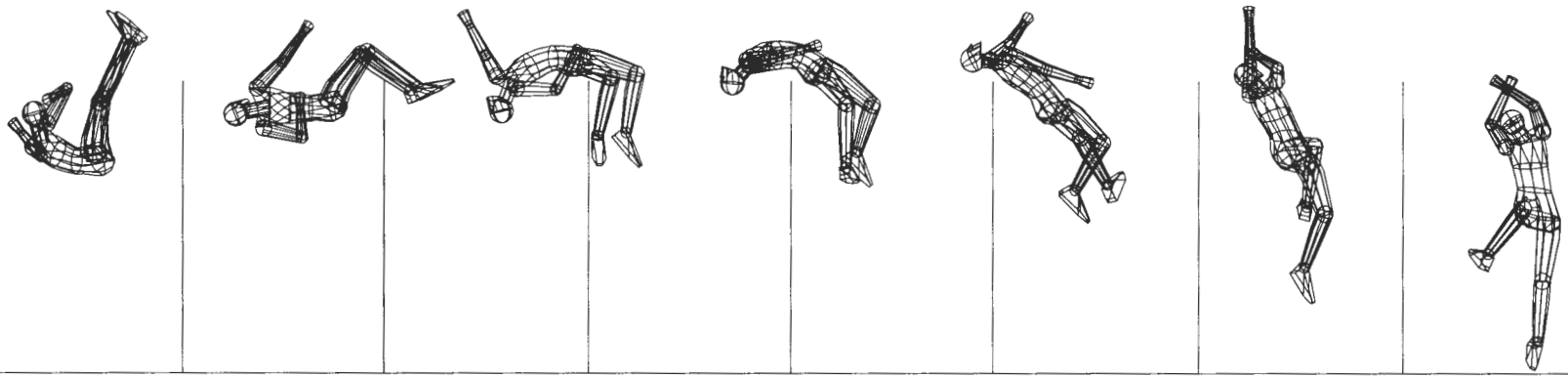

10.94

10.82

10.70

10.58

10.46

10.34

10.22

C.M. HEIGHT VS TIME

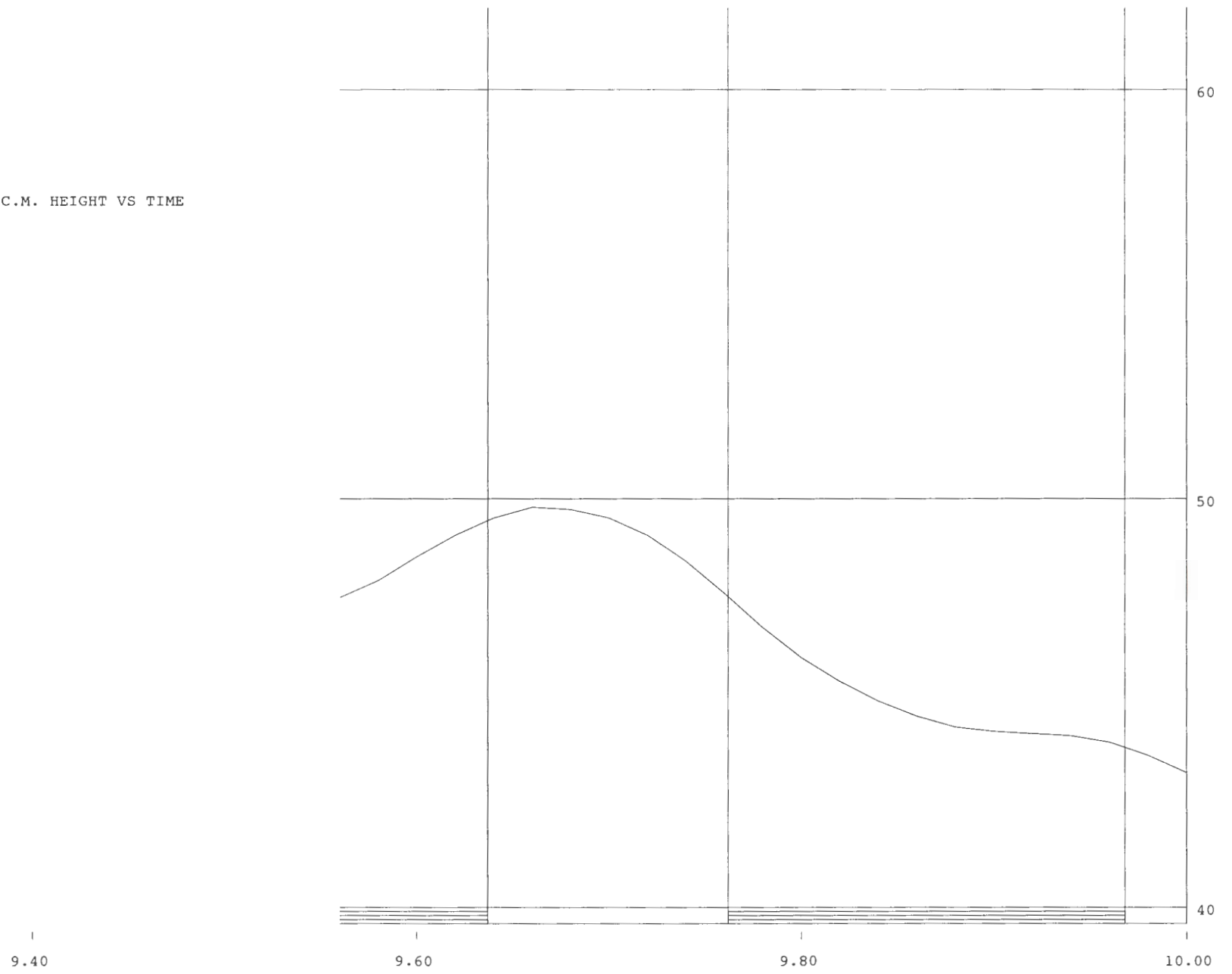

HUTCHINSON #72 062407 2.21 M CLEARANCE

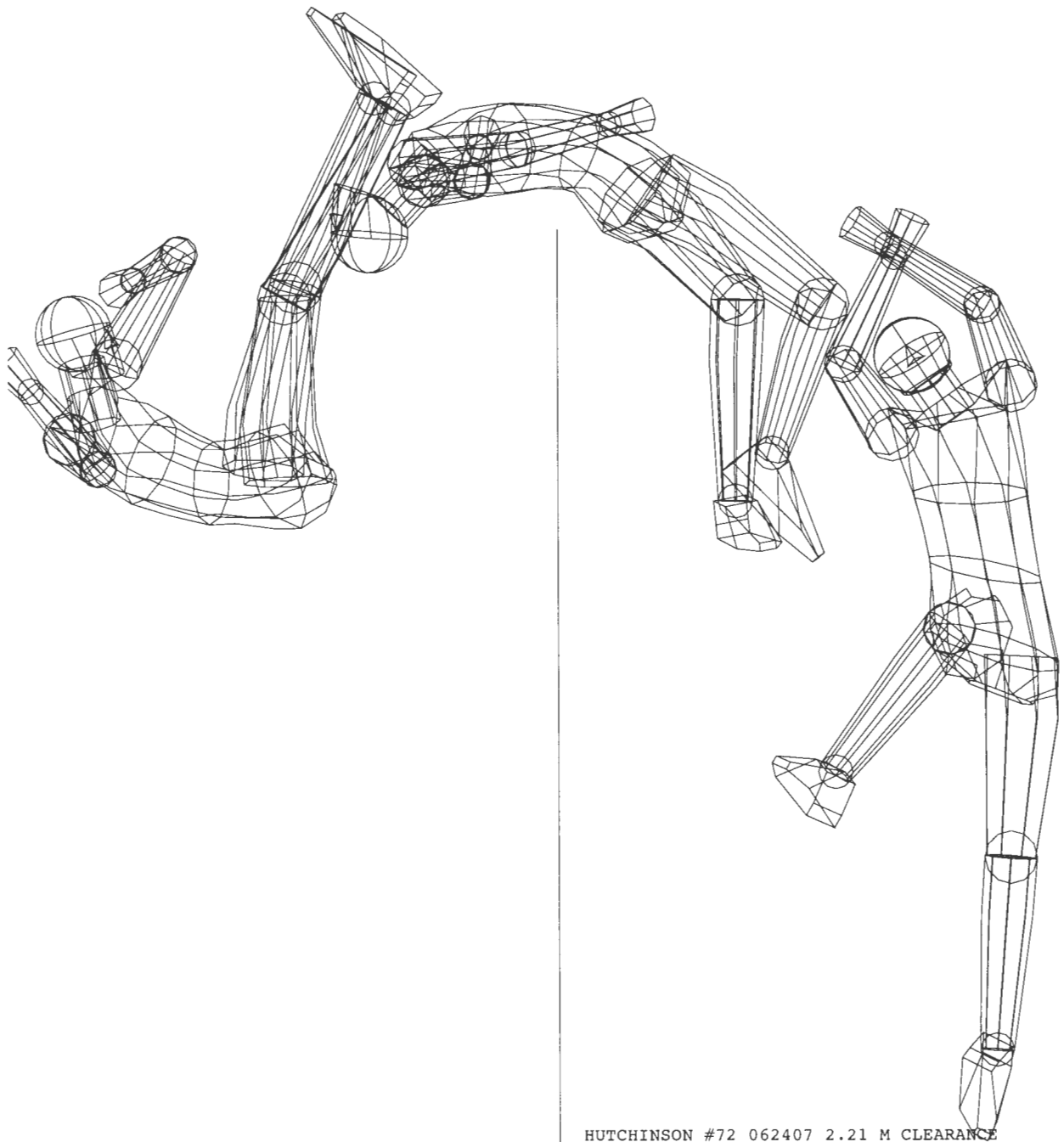

HUTCHINSON #72 062407 2.21 M CLEARANCE

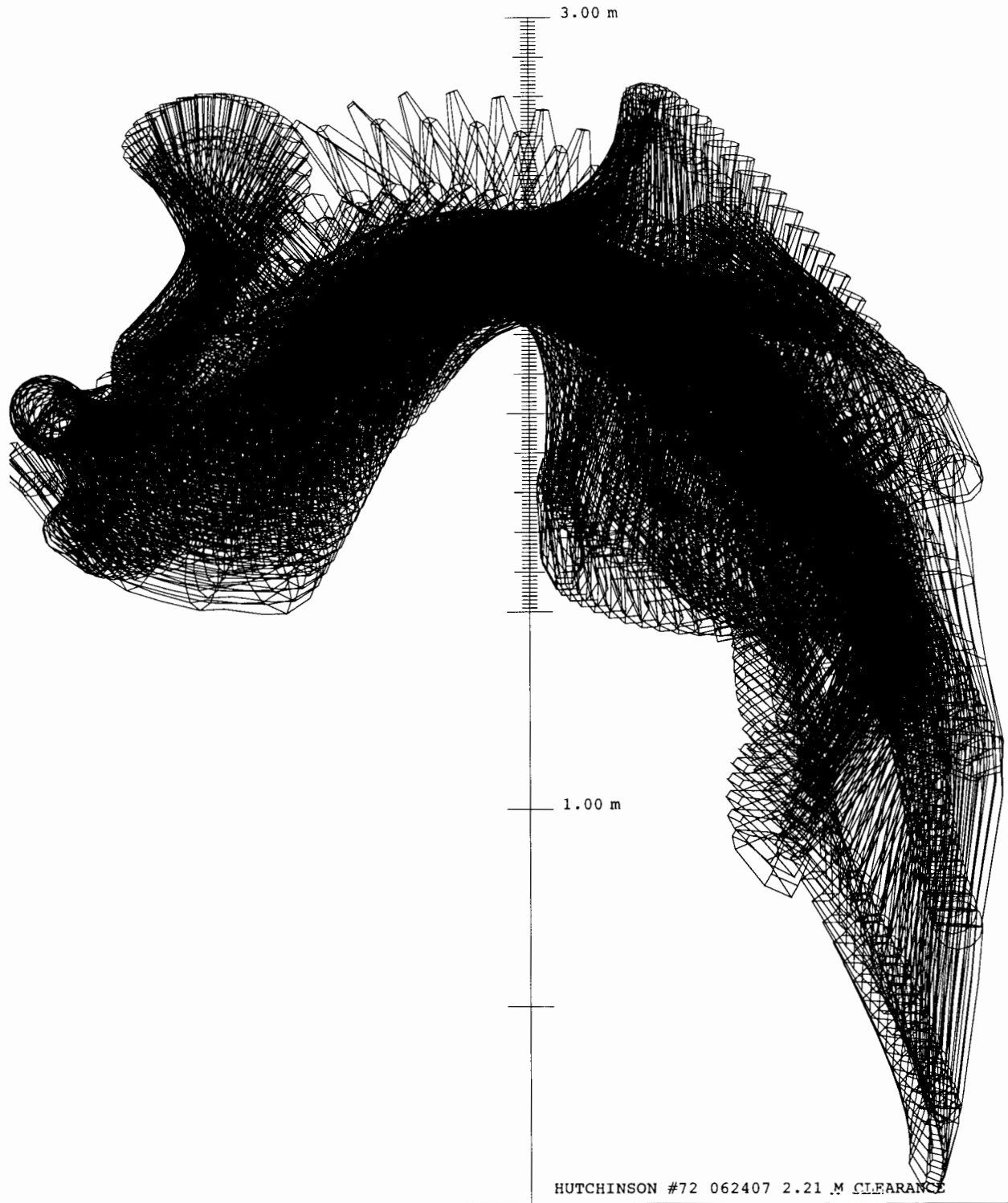

HUTCHINSON #72 062407 2.21 M CLEARANCE

Will LITTLETON

Jump 48 was Littleton's last successful clearance at the 2007 USATF Championships (2.18 m).

Littleton's vertical velocity at takeoff in jump 48 was $v_{ZTO} = 4.15$ m/s. However, the USATF Championships were not a very good competition for him, and thus Littleton's 4.15 m/s v_{ZTO} value presents a distorted view of his physical condition during the 2007 season. Littleton's best mark of the season was 2.28 m. Even though we have no hard data on his 2.28 m jump, we can estimate fairly accurately that he must have generated about 4.35 m/s of vertical velocity in that jump. Therefore, we will consider $v_{ZTO} = 4.35$ m/s the best indicator of Littleton's physical condition.

Based on a vertical velocity at takeoff of $v_{ZTO} = 4.35$ m/s, a technique of average quality would have included a final run-up speed of about 7.4 m/s and a c.m. height at the end of the run-up equal to about 47% of his own standing height. In jump 48, Littleton was actually slightly lower at the end of the run-up ($h_{TD} = 46\%$) than what would be expected in a technique of average quality, and he was also much faster ($v_{HI} = 7.9$ m/s). This was a very good combination for him.

At the end of the run-up, Littleton planted the takeoff foot too parallel to the bar. Because of this, the angle between the longitudinal axis of the takeoff foot and the horizontal force received by the foot was too large ($e_3 = 34^\circ$). This would normally lead us to predict a risk of foot pronation, and injury to the ankle and foot. (See the section on "Orientation of the takeoff foot, and potential for ankle and foot injuries" in the main text of the report.) However, direct examination of the videos showed only moderate amounts of pronation in Littleton's jumps.

Until last year we recorded the jumps with movie cameras (16 mm film), and the images of the jumps were generally not clear enough to actually see the pronation of the foot during the takeoff phase. This year, we have switched to high definition video cameras, and the images are clearer. This sometimes allows us to see the pronation when it occurs. The images in this page show screen captures of two separate views of Littleton's takeoff foot during the takeoff phase in jump 48. Only a small amount of pronation is evident. Both views showed that the foot rolled: The left image of the bottom sequence shows the tilted shoe; the top sequence does not show the tilt directly, but it does show that the outside edge of the shoe actually lifted off from the ground

2.18 m clearance (jump 48)

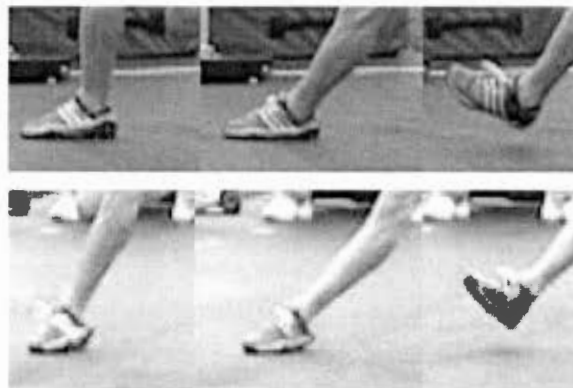

between the middle image and the image on the left, as indicated by the larger amount of black sole visible in the image on the left. Other jumps by Littleton during the competition showed similar signs of pronation. It is true that the amount of pronation does not seem very severe in these images, but we need to keep in mind that neither one of these two sequences were taken from the best viewpoint for the observation of pronation, so it is possible that the pronation might be more severe than what meets the eye.

Littleton did not prepare his arms for a double-arm takeoff. (See the side-view and back-view sequences of the run-up between $t = 9.58$ s and $t = 10.00$ s.) Still, he managed to have both arms in moderately low positions at the start of the takeoff phase ($t = 10.00$ s), which raised the possibility that he might still be able to use reasonably strong arm actions during the takeoff phase. Indeed, Littleton lifted his right arm to a high position by the end of the takeoff phase, so its action was fairly strong (AAN = 8.2 mm/m). (See the detailed sequence of the takeoff phase between $t = 10.00$ s and $t = 10.16$ s; see also Figure 9 in the main text of the report.) He also lifted his left elbow to a high position by the end of the takeoff phase, but in addition he executed an internal rotation of the left upper arm that put the left forearm in a horizontal orientation at the end of the takeoff, which put the left wrist barely higher than the left elbow and shoulder. (See the sequence of the takeoff phase at $t = 10.16$ s.) This made the action of Littleton's left arm be very weak (AAF = 7.2 mm/m). Keep in mind that the arm farthest from the bar (the left arm in Littleton's case) is the one that normally makes a stronger action in most high jumpers. Because of the weak action of his left arm, Littleton's total arm action was somewhat weak (AAT = 15.5 mm/m). Littleton did not lift his right knee high enough at the end of the takeoff phase. Therefore,

the action of his lead leg was weak ($LLA = 15.3$ mm/m). His overall combination of arm and lead leg actions was also weak ($FLA = 30.8$ mm/m).

In jump 48, Littleton's trunk had only a very small amount of backward lean at the start of the takeoff phase ($BFTD = 84^\circ$). Then he rotated forward, and by the end of the takeoff his trunk was vertical ($BFTO = 90^\circ$). This position at the end of the takeoff phase was very good. But, given that Littleton's backward lean at the start of the takeoff phase was very small, and that he did not rotate forward through a very large angle during the takeoff phase (since he had not gone beyond the vertical by the end of the takeoff), we expected him to generate only a limited amount of forward somersaulting angular momentum. However, he was able to generate a large amount of forward somersaulting angular momentum ($H_F = 90$). It's not entirely clear how Littleton managed to do this. In part, it may have been facilitated by the weakness of his arm and lead leg actions. (Weak arm and lead leg actions can hamper the generation of lift, but they do facilitate the generation of forward somersaulting angular momentum.)

Littleton's trunk had a moderate amount of lean toward the left at the start of the takeoff phase ($LRTD = 79^\circ$). Then he rotated toward the right, and by the end of the takeoff he was 11° past the vertical in the view from the back ($LRTO = 101^\circ$). In the view from the back, it's normal to go a few degrees past the vertical at the end of the takeoff. We consider it acceptable (indeed, desirable) to tilt up to 10° past the vertical at the end of the takeoff (in the view from the back) because we believe that this may be the best compromise between the generation of lift and the generation of rotation (angular momentum). Littleton was essentially at the acceptable limit for lean toward the right at the end of the takeoff phase. That was very good. The fact that Littleton had only a moderate amount of lean toward the left at the start of the takeoff phase limited somewhat the amount of rotation toward the right that he could go through during the takeoff phase without being over-rotated at the end of the takeoff. Because of this, the amount of lateral somersaulting angular momentum that he was able to generate was somewhat small ($H_L = 90$).

Littleton's forward and lateral components of somersaulting angular momentum added up to a good total amount of somersaulting angular momentum ($H_S = 125$).

The peak height reached by the c.m. in jump 48

was $h_{PK} = 2.20$ m. The "saturation graph" shows that in this jump Littleton could have cleared cleanly a bar set also at about $h_{CLS} = 2.20$ m. In relation to the peak height of the c.m. (2.20 m), the 2.20 m clean clearance height indicated an extremely effective bar clearance.

Recommendations

Almost all aspects of Littleton's technique were very good. He was reasonably low and very fast at the end of the run-up. Then, without producing excessive leans forward nor toward the right at the end of the takeoff, he generated good amounts of angular momentum, which contributed to make his bar clearance extremely effective. These are some of the most important technique aspects of high jumping, and Littleton did them all very well.

The only significant concern that we have about Littleton's technique is the orientation of his left foot during the takeoff phase. He planted the takeoff foot too parallel to the bar. Based on this, we advise him to plant the takeoff foot on the ground with its longitudinal axis more in line with the final direction of the run-up, with the toe pointing at least 15° more clockwise than in jump 48. This technique change will help to prevent foot pronation, and injury to the ankle and foot.

In the past, to advise high jumpers about the appropriate orientation of the takeoff foot, we relied exclusively on the orientation of the takeoff foot relative to the direction of the horizontal force made by the athlete on the ground during the takeoff phase (angle e_3). This was because it was almost never possible to actually see the foot pronation in the images of the 16 mm movie film that we used. This has changed to some extent with our switch to high definition video. The images are much clearer, and we have a better chance of actually seeing the pronation in the video images. For athletes who approach from the left, we can generally see the pronation quite well if it occurs. Unfortunately, for athletes who approach from the right (like Littleton), it is not so easy to see, due to the positions in which we have to place our cameras. Still, we were able to detect some pronation in most of Littleton's jumps. Because of the rather large value of the e_3 angle in jump 48 and the existence of pronation in Littleton's jumps (even though we can't judge very well how severe that pronation was), our advice to Littleton is to play it safe by planting the takeoff foot more in line with the final direction of the run-up.

Other than the just described change in the orientation of the takeoff foot, we have no other strong advice for Littleton. Sure, we could advise him to swing his left arm and the knee of his right leg harder forward and up, to higher positions by the end of the takeoff phase. Such actions might allow Littleton to generate more lift. However, it is possible that, with his very fast and low run-up, Littleton might be already near his limit for buckling, in which case a marked increase in his arm or lead leg actions might be counterproductive.

Even if increased arm and lead leg actions would increase Littleton's lift (which is something that we are not sure of), they could also produce other problems unless other changes are also incorporated into his technique, as will be explained next. As we stated previously, it is possible that the weakness of Littleton's arm and lead leg actions might be what allows him to generate a good total amount of somersaulting angular momentum, because they compensate for the problem created by the very small size of his backward lean at the start of the takeoff phase. If Littleton strengthened his arm and lead leg actions without first correcting (i.e., increasing) his backward lean at the start of the takeoff phase, it is possible that the amount of forward somersaulting angular momentum that he would be able to generate would become smaller. This would reduce his total amount of somersaulting angular momentum, which in turn would probably deteriorate the effectiveness of Littleton's bar clearance. Thus, what Littleton would gain in lift (through his enhanced arm and lead leg actions) might be lost through reduced effectiveness in his bar clearance. Therefore, simply making stronger use of the arms and lead leg during the takeoff phase is probably not a good idea for Littleton.

What would happen if Littleton were to thrust his hips further forward in the last step of the run-up, and thus acquire a larger amount of backward lean at the start of the takeoff phase? In such case, he would have available a larger range of motion of forward rotation from there all the way to the vertical by the end of the takeoff phase, and this would favor the generation of a larger amount of forward somersaulting angular momentum. This would compensate for any angular momentum loss produced by the use of stronger arm and lead leg actions. In this way, Littleton might be able to generate more lift through stronger use of his arms and lead leg without incurring any ill effects on the effectiveness of his bar clearance. This sounds like a good idea. However, it brings us back to the fact that we don't know if enhanced arm and lead leg actions

will actually produce more lift for Littleton. (See the previous two paragraphs.) Taking all of this into account, is it worthwhile to experiment with all these changes? We think that it probably isn't. Our advice is to work only on the improved orientation of the takeoff foot, and to leave everything else in Littleton's technique as it was in jump 48.

Future improvements in Littleton's results will probably need to be based on improvements in his physical condition rather than in his technique, because his technique is already very good.

LITTLETON #48 062407 2.18 M CLEARANCE

RUN-UP

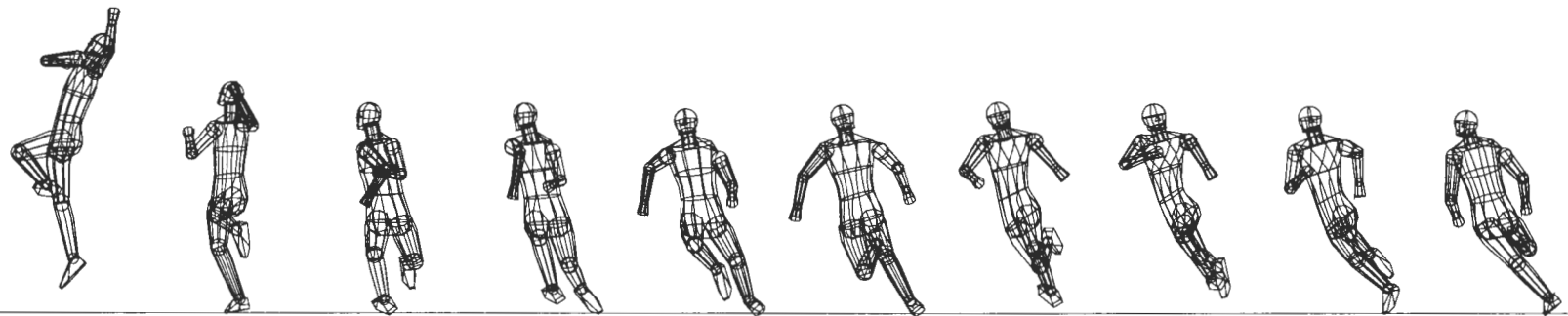
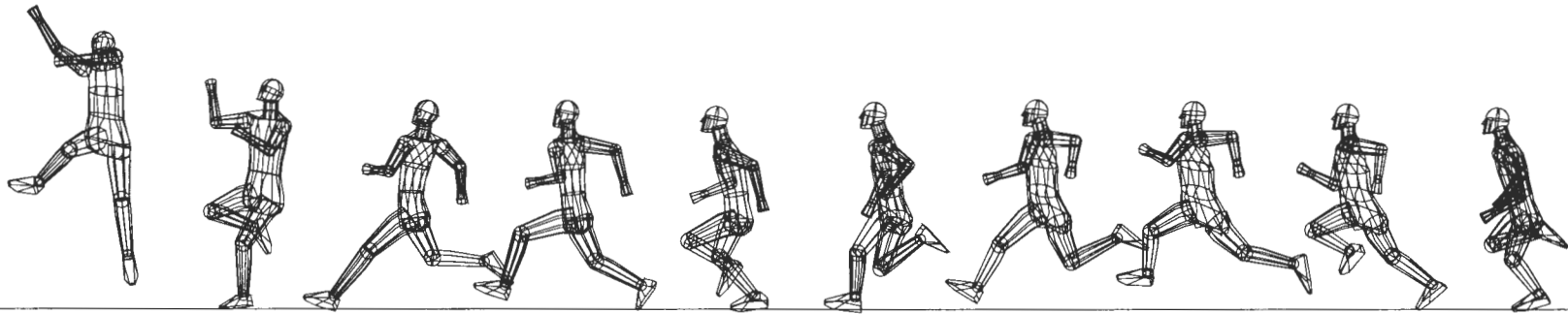

10.20

10.10

10.00

9.94

9.88

9.82

9.76

9.70

9.64

9.58

LITTLETON #48 062407 2.18 M CLEARANCE

TAKEOFF PHASE

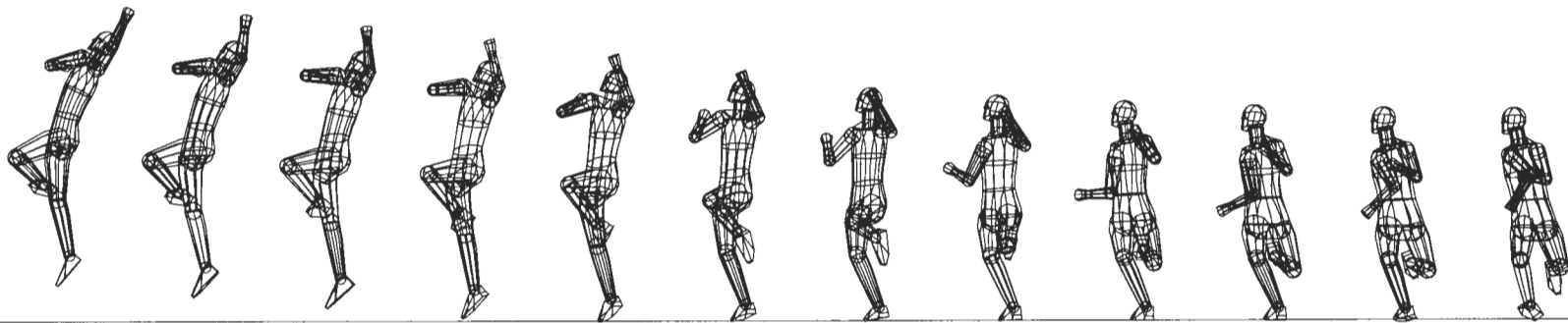
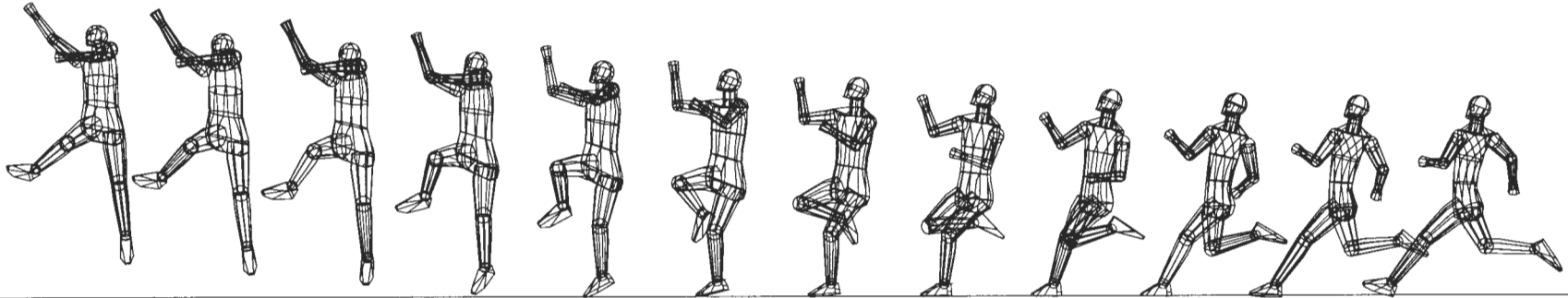

10.22

10.20

10.18

10.16

10.14

10.12

10.10

10.08

10.06

10.04

10.02

10.00

LITTLETON #48 062407 2.18 M CLEARANCE

BAR CLEARANCE

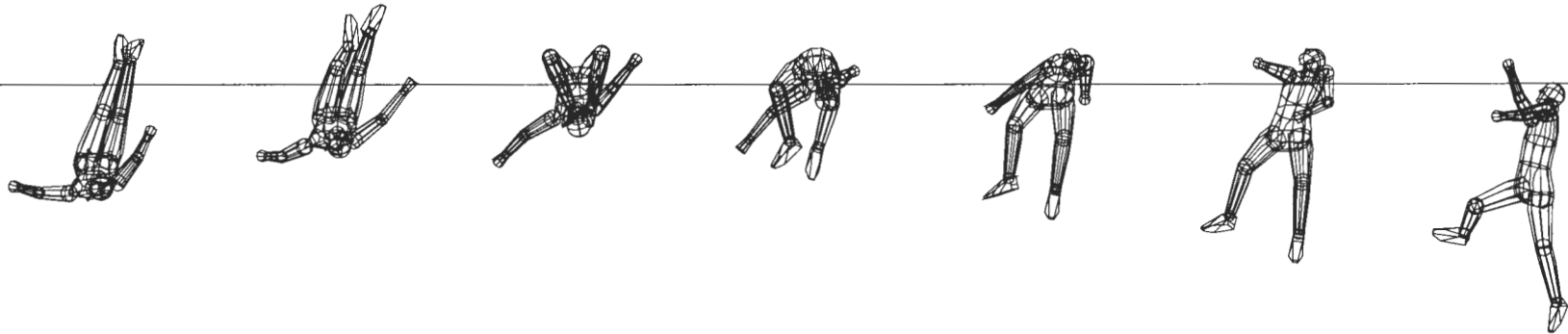
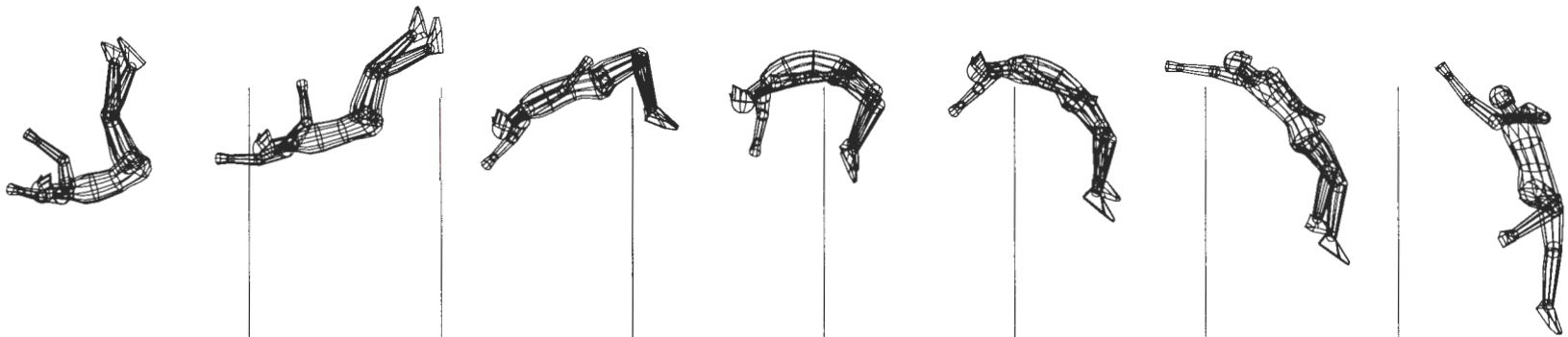

10.94

10.82

10.70

10.58

10.46

10.34

10.22

C.M. HEIGHT VS TIME

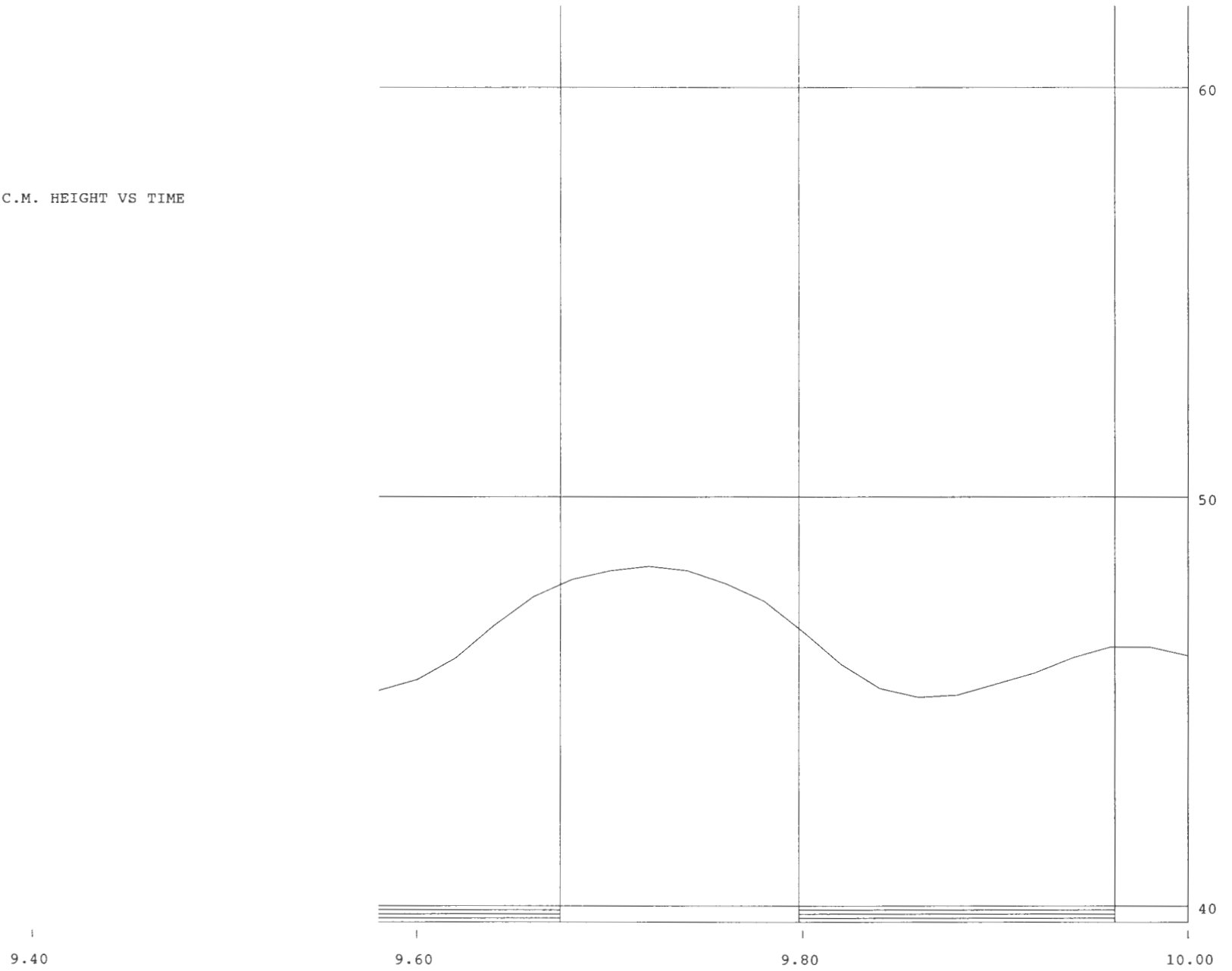

LITTLETON #48 062407 2.18 M CLEARANCE

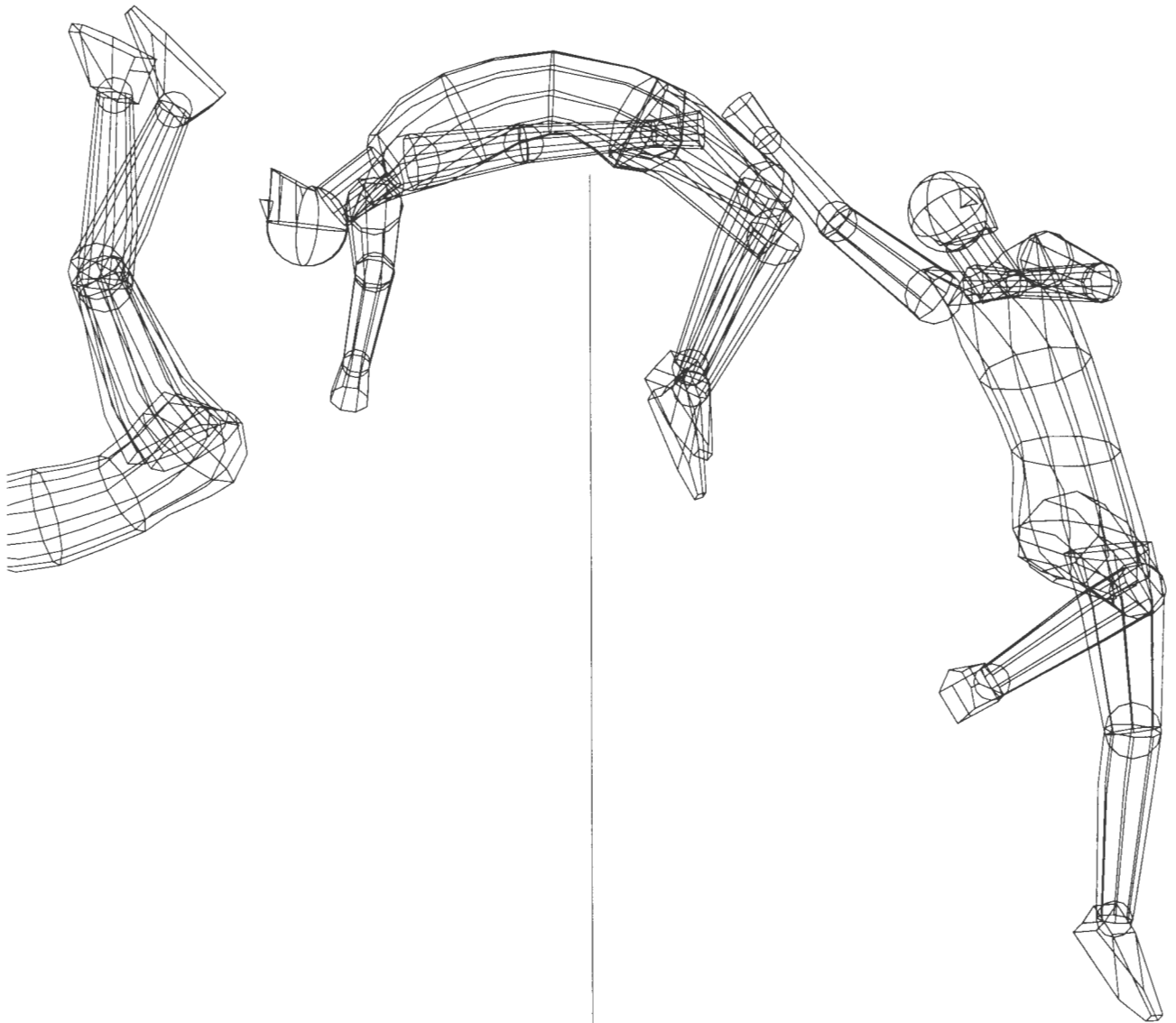

LITTLETON #48 062407 2.18 M CLEARANCE

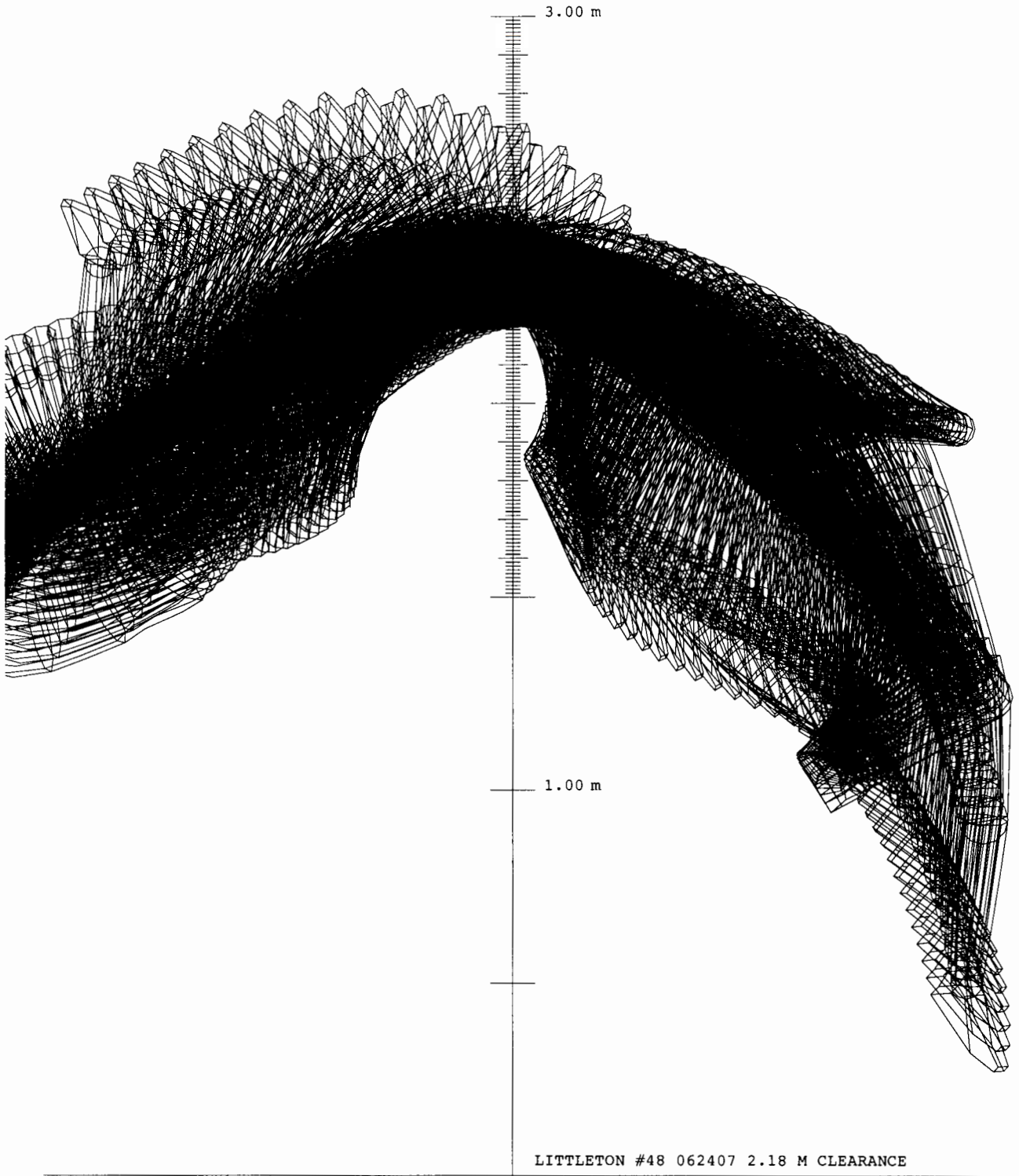

LITTLETON #48 062407 2.18 M CLEARANCE

Keith MOFFATT

Jump 84 was Moffatt's last successful clearance at the 2007 USATF Championships (2.24 m).

Based on Moffatt's vertical velocity at takeoff in jump 84 ($v_{ZTO} = 4.30$ m/s), a technique of average quality would have included a final run-up speed of about 7.4 m/s and a c.m. height at the end of the run-up equal to about 47% of his own standing height. At the end of the run-up, Moffatt's c.m. was actually higher than what would be expected for a technique of average quality ($h_{TD} = 48.5\%$), and his speed was slower ($v_{HI} = 7.2$ m/s). This overall combination of run-up speed and c.m. height that Moffatt used in jump 84 was a very weak challenge for a jumper capable of generating 4.30 m/s of vertical velocity. In fact, it was worse than the combinations that he used in his previous analyzed jumps. Over time, Moffatt has used progressively weaker combinations of final speed and c.m. height at the end of the run-up. (See the graphic below, based on Figure 3.) This is the most important performance-related problem in Moffatt's technique.

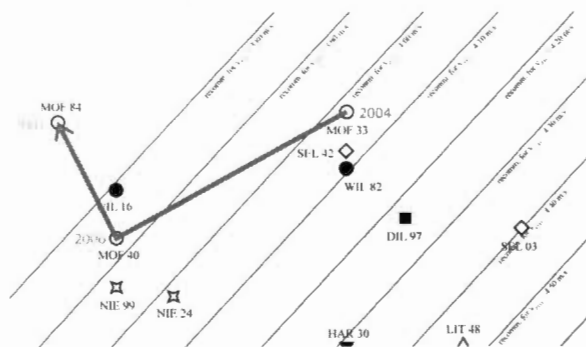

At the end of the run-up of jump 84, Moffatt planted the takeoff foot too parallel to the bar. Because of this, the angle between the longitudinal axis of the takeoff foot and the horizontal force received by the foot was too large ($e_3 = 28^\circ$), and created a risk of ankle pronation, and injury to the ankle and foot. (See the section on "Orientation of the takeoff foot, and potential for ankle and foot injuries" in the main text of the report.)

Until last year we recorded the jumps with movie cameras (16 mm film), and the images of the jumps were generally not clear enough to actually see the pronation of the foot during the takeoff phase. This year, we have switched to high definition video cameras, and the images are clearer. This sometimes allows us to see the pronation when it occurs. The sequence images on this page show screen captures of Moffatt's takeoff foot during the takeoff phase in

2.24 m clearance
(jump 84)



2.27 m third miss



his 2.24 m clearance (jump 84) and in his third miss at 2.27 m. Even though this camera view is not the best for the observation of takeoff foot pronation, it is clear that there was pronation: In both jumps, the outside edge of the shoe lifted off from the ground between the middle image and the image on the left. The effect was more marked in the bottom jump.

Moffatt's arm actions during the takeoff phase were weak (AAT = 12.0 mm/m). The action of the lead leg was strong (LLA = 19.6 mm/m). The overall combination of arm and lead leg actions was somewhat weak (FLA = 31.6 mm/m), weaker than in 2006.

Moffatt had only a small amount of backward lean at the start of the takeoff phase in jump 84 (BFTD = 87°). By itself, this presented a problem for the generation of forward somersaulting angular momentum. But then the problem was compounded: As in 2004 and 2006, instead of rotating forward toward the vertical during the takeoff phase, Moffatt's trunk actually rotated backward, so that at the end of the takeoff his trunk had a larger backward lean than at the start (BFTO = 83°). Given this, it was not surprising that Moffatt was only able to generate a very small amount of forward somersaulting angular momentum ($H_F = 45$).

Moffatt's trunk had a moderate lean toward the left at the start of the takeoff phase (LRTD = 79°). Then, he rotated toward the right during the takeoff phase, and by the end of the takeoff he was 11° past the vertical in the view from the back (LRTO = 101°). In the view from the back, it's normal to go a few degrees past the vertical at the end of the takeoff.

We consider it acceptable (indeed, desirable) to tilt up to 10° past the vertical at the end of the takeoff phase (in the view from the back) because we believe that this may be the best compromise between the generation of lift and the generation of rotation (angular momentum). So Moffatt was essentially at the allowable limit for tilt at the end of the takeoff. This was good, and an improvement relative to 2006. Moffatt was able to generate a good amount of lateral somersaulting angular momentum ($H_L = 95$).

Moffatt's very small forward and large lateral components of somersaulting angular momentum added up to a small total amount of somersaulting angular momentum ($H_S = 105$).

The peak height reached by the c.m. in jump 84 was $h_{PK} = 2.33$ m. The "saturation graph" shows that in this jump Moffatt could have cleared cleanly a bar set at about $h_{CLS} = 2.25$ m, and at $h_{CLA} = 2.27$ m if he had taken off about 10 cm closer to the bar. In relation to the peak height of the c.m. (2.33 m), the 2.27 m clean clearance height indicated that Moffatt's bar clearance was not very effective.

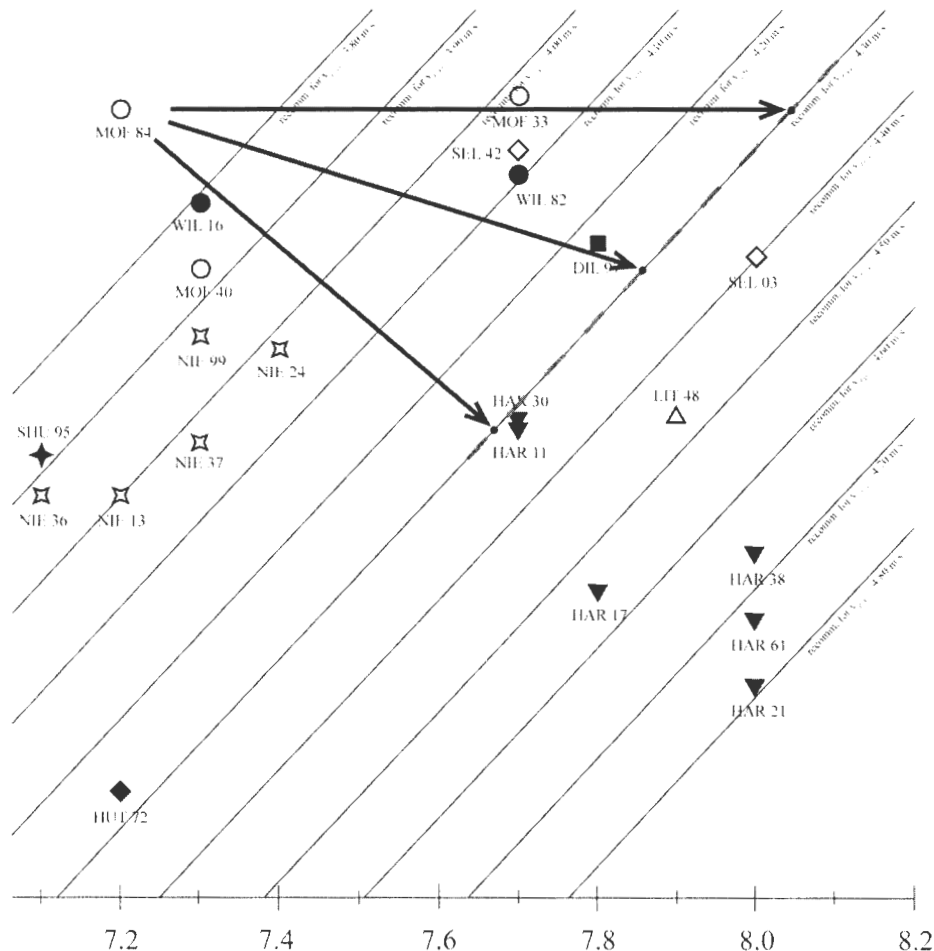

Recommendations

To a great extent, our recommendations to Moffatt are the same as last year's.

In jump 84, Moffatt was very high and very slow at the end of the run-up. This is the most important performance-related problem in his technique. Moffatt needs to be much faster and/or lower. For any jumper, the optimum combination of run-up speed and c.m. height at the end of the run-up is faster and/or lower than the expected average ("ordinary") combination. In terms of Figure 3, all solutions to this problem involve moving Moffatt's point to the diagonal line recommended for $v_{ZTO} = 4.30$ m/s. One possible option would be to combine the height that Moffatt had at the end of the run-up in jump 84 ($h_{TD} = 48.5\%$) with a much faster speed ($v_{HI} = 8.0$ - 8.1 m/s). (See the horizontal arrow in the graph below.) This larger amount of final run-up speed should allow Moffatt to generate more lift during the takeoff phase, and thus to produce a larger height for his c.m. at the peak of the jump. (See Appendix 2 for exercises that will help to produce fast and low conditions at the end of the run-up.)

An alternative option would be to put the c.m. at the end of the run-up in a lower position, equivalent to about 47% of Moffatt's own standing height. This would be a final run-up height similar to the one used by Moffatt in jump 40 from 2006. With such a position at the end of the run-up, a final horizontal speed of about 7.8-7.9 m/s would be sufficient to qualify as optimal. (See the intermediate arrow in the graph.)

A third possibility would be to put the c.m. at the end of the run-up in a still lower position, equivalent to about 46% of Moffatt's own standing height. This would be a final run-up height similar to those used by Littleton or Shunk at the 2007 USATF Championships. With such a position at the

end of the run-up, a final horizontal speed of about 7.7 m/s would be sufficient to qualify as optimal. (See the lowest of the three arrows in the graph.)

(Standard caution when increasing the run-up speed and/or lowering the c.m. height at the end of the run-up: *The use of a faster and/or lower run-up will put a greater stress on the takeoff leg, and thus it may increase the risk of injury if the leg is not strong enough. Therefore, it is always important to use caution in the adoption of a faster and/or lower run-up. If the desired change is very large, it would be advisable to make it gradually, over a period of time. In all cases, it may be wise to further strengthen the takeoff leg, so that it can withstand the increased force of the impact produced when the takeoff leg is planted.*)

Based on the angle between the longitudinal axis of the takeoff foot and the horizontal force received by the foot (angle ϵ_3) in jump 84, Moffatt's foot orientation did not seem too dangerous. However, the video images strongly suggested that the problem may be more serious. Therefore, we advise Moffatt to plant the takeoff foot on the ground with the longitudinal axis of the foot more in line with the final direction of the run-up: It should be planted on the ground in a more clockwise orientation, with the toe pointing at least 10° more toward the landing pit than in jump 84. This technique change should help to prevent ankle pronation, and injury to the ankle and foot.

In regard to Moffatt's forward/backward and left-right leans during the takeoff phase, and to his bar clearance, the changes in these aspects of his technique since last year have been quite small. Please refer to the advice given in last year's report in regard to these aspects of Moffatt's technique.

Moffatt's arm actions during the takeoff phase suffered some deterioration between 2006 and 2007. Moffatt needs to thrust his arms harder forward and upward during the takeoff phase, to a higher position by the end of the takeoff. These actions will help him to generate more lift. The action of Moffatt's lead leg during the takeoff phase is not bad, and therefore it does not need any changes.

The changes proposed for Moffatt are, by order of importance: (a) correct the orientation of the takeoff foot—this is an important safety-related issue; (b) use a faster speed and a lower position at the end of the run-up—this is the most important performance-related issue; (c) make changes in the bar clearance technique, as explained in last year's

report; (d) use stronger arm actions during the takeoff phase.

Among the athletes analyzed in this report, Moffatt is probably the one who is performing farthest from his potential. If he ever corrects his many and important technique problems, he could make tremendous progress in his high jump results.

MOFFATT #84 062407 2.24 M CLEARANCE

RUN-UP

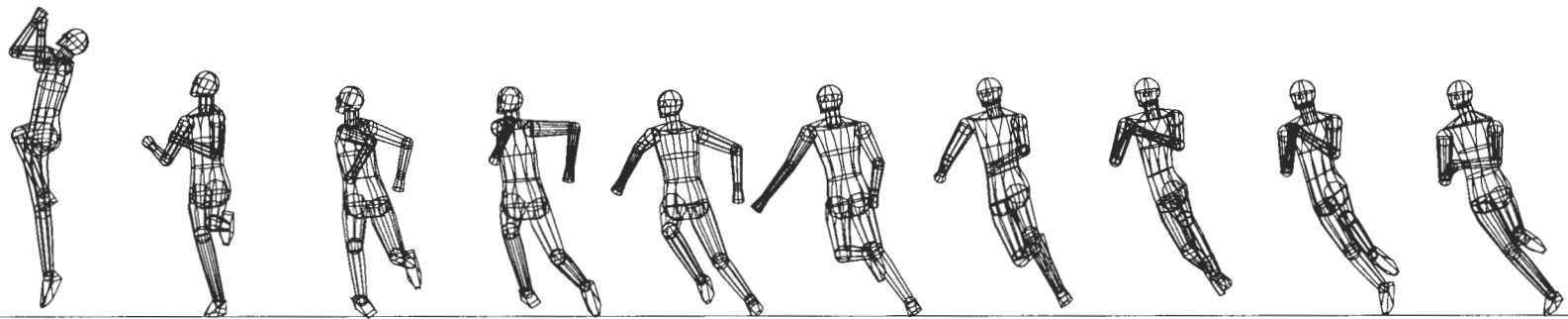
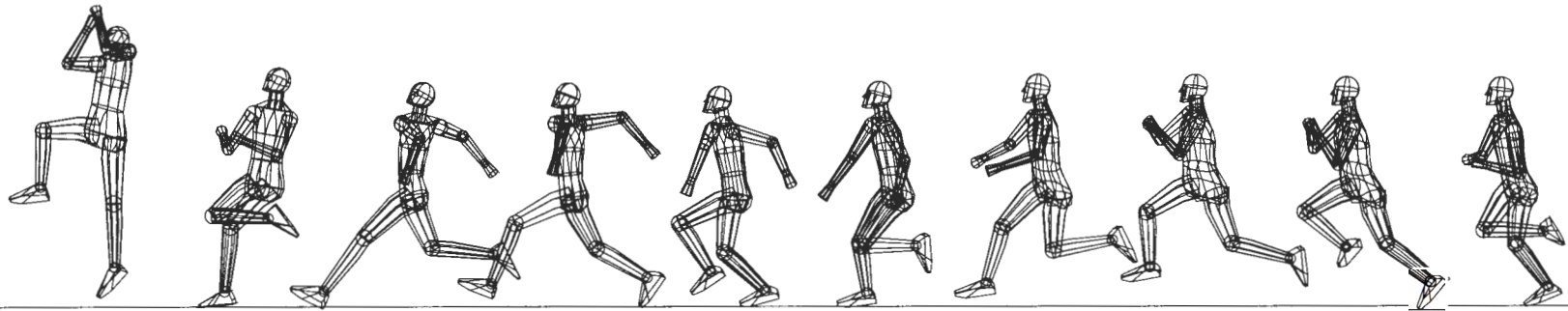

10.20

10.10

10.00

9.94

9.88

9.82

9.76

9.70

9.64

9.58

MOFFATT #84 062407 2.24 M CLEARANCE

TAKEOFF PHASE

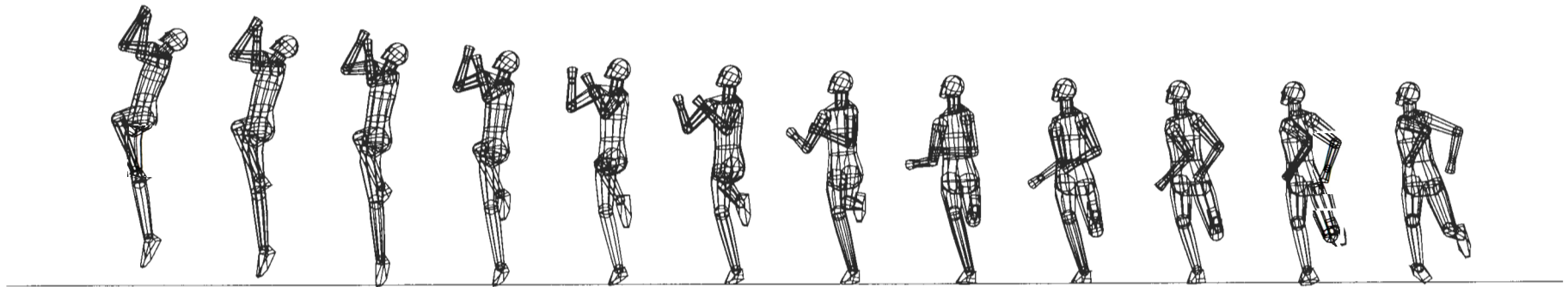
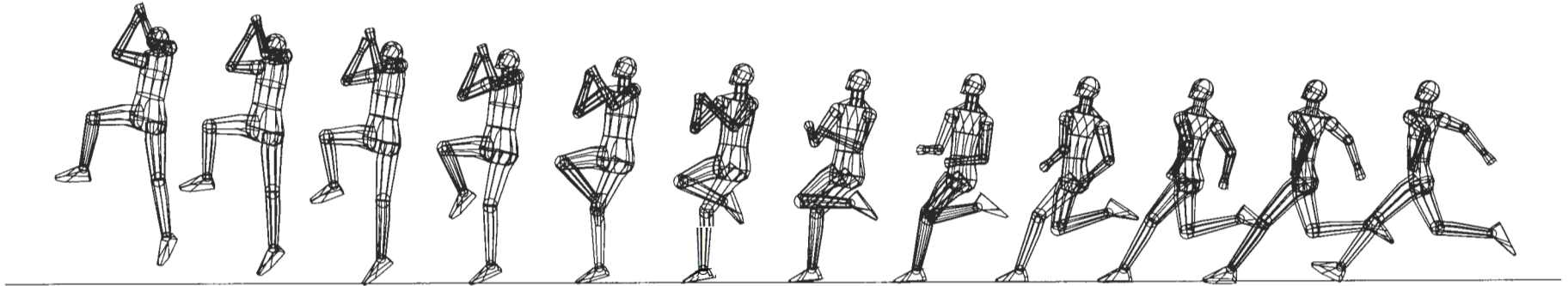

10.22

10.20

10.18

10.16

10.14

10.12

10.10

10.08

10.06

10.04

10.02

10.00

MOFFATT #84 062407 2.24 M CLEARANCE

BAR CLEARANCE

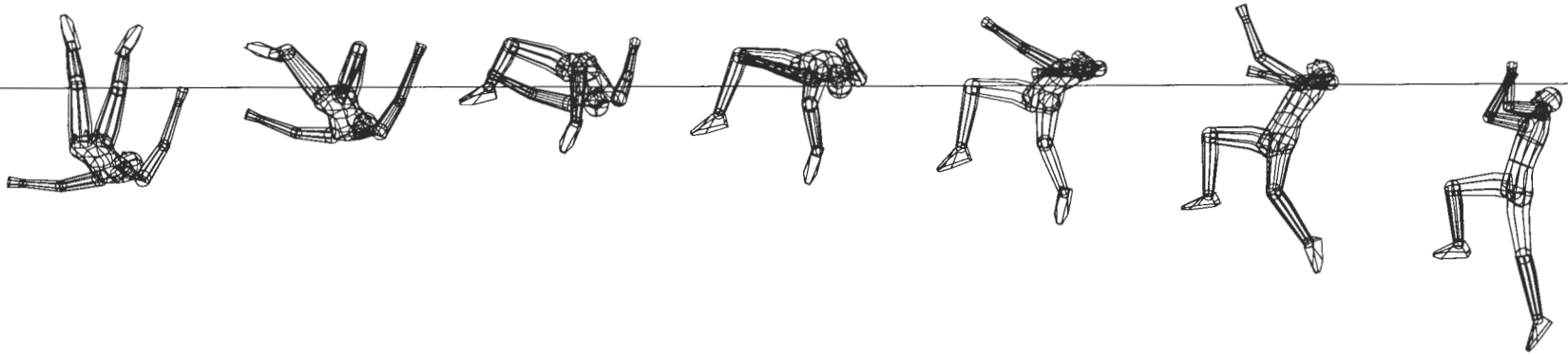
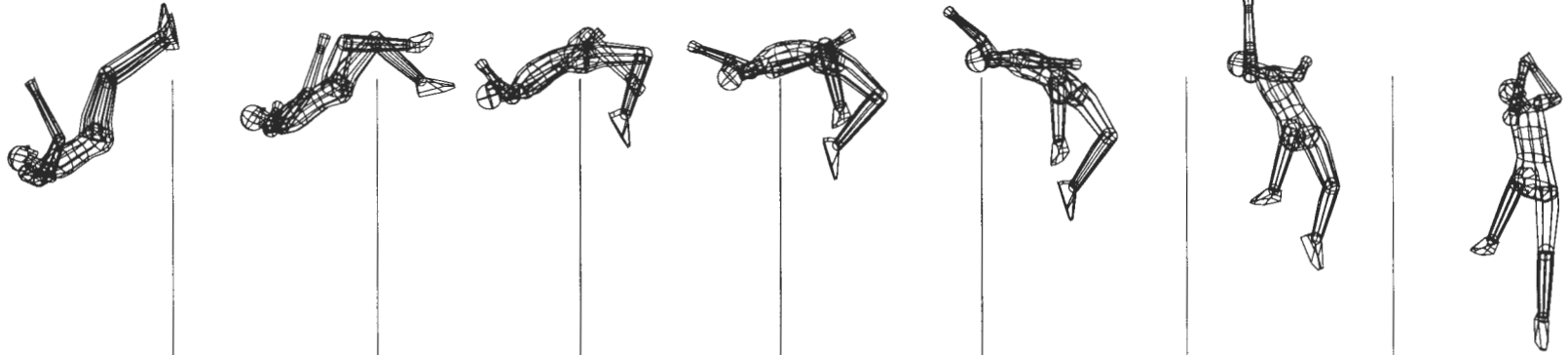

10.94

10.82

10.70

10.58

10.46

10.34

10.22

C.M. HEIGHT VS TIME

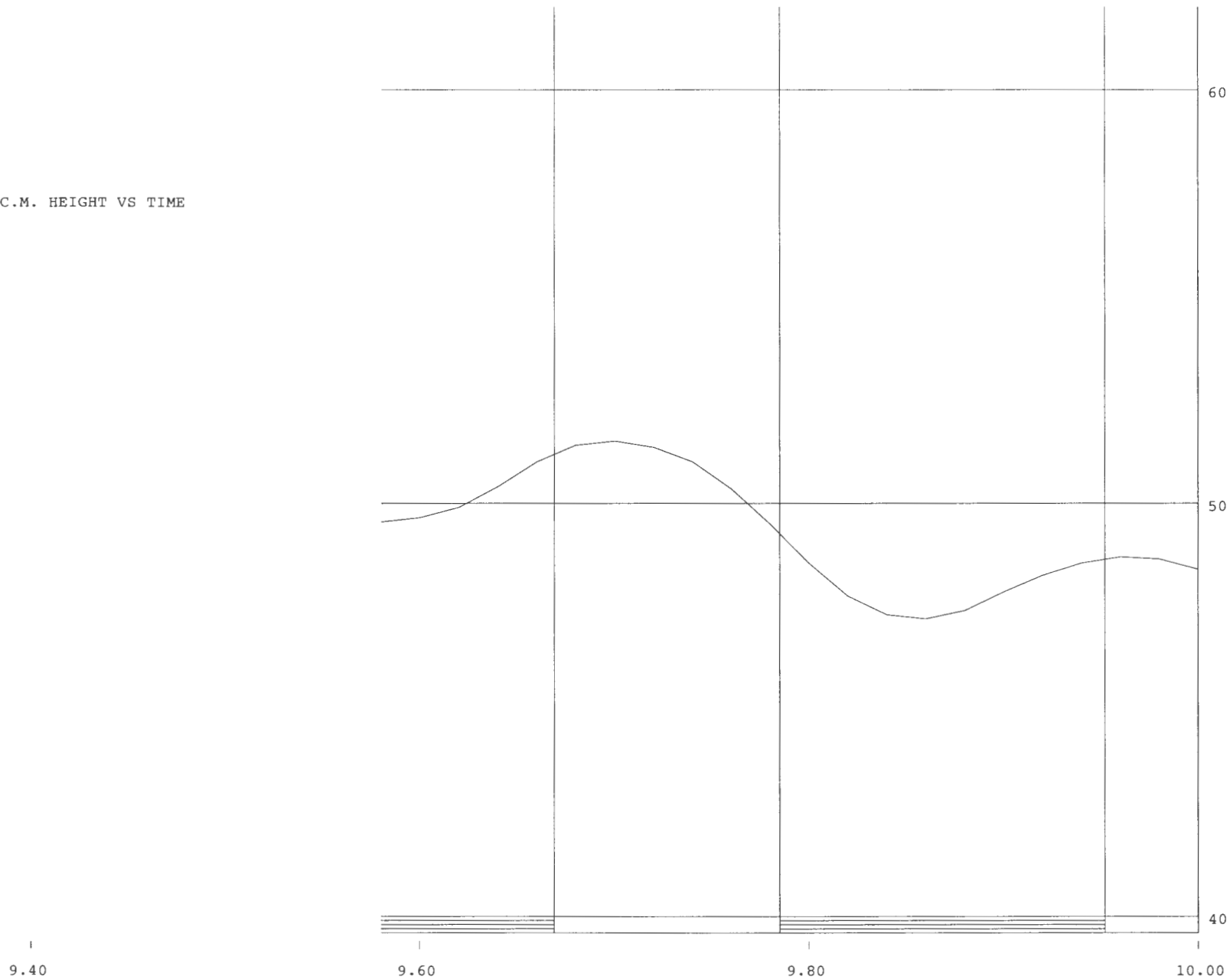

MOFFATT #84 062407 2.24 M CLEARANCE

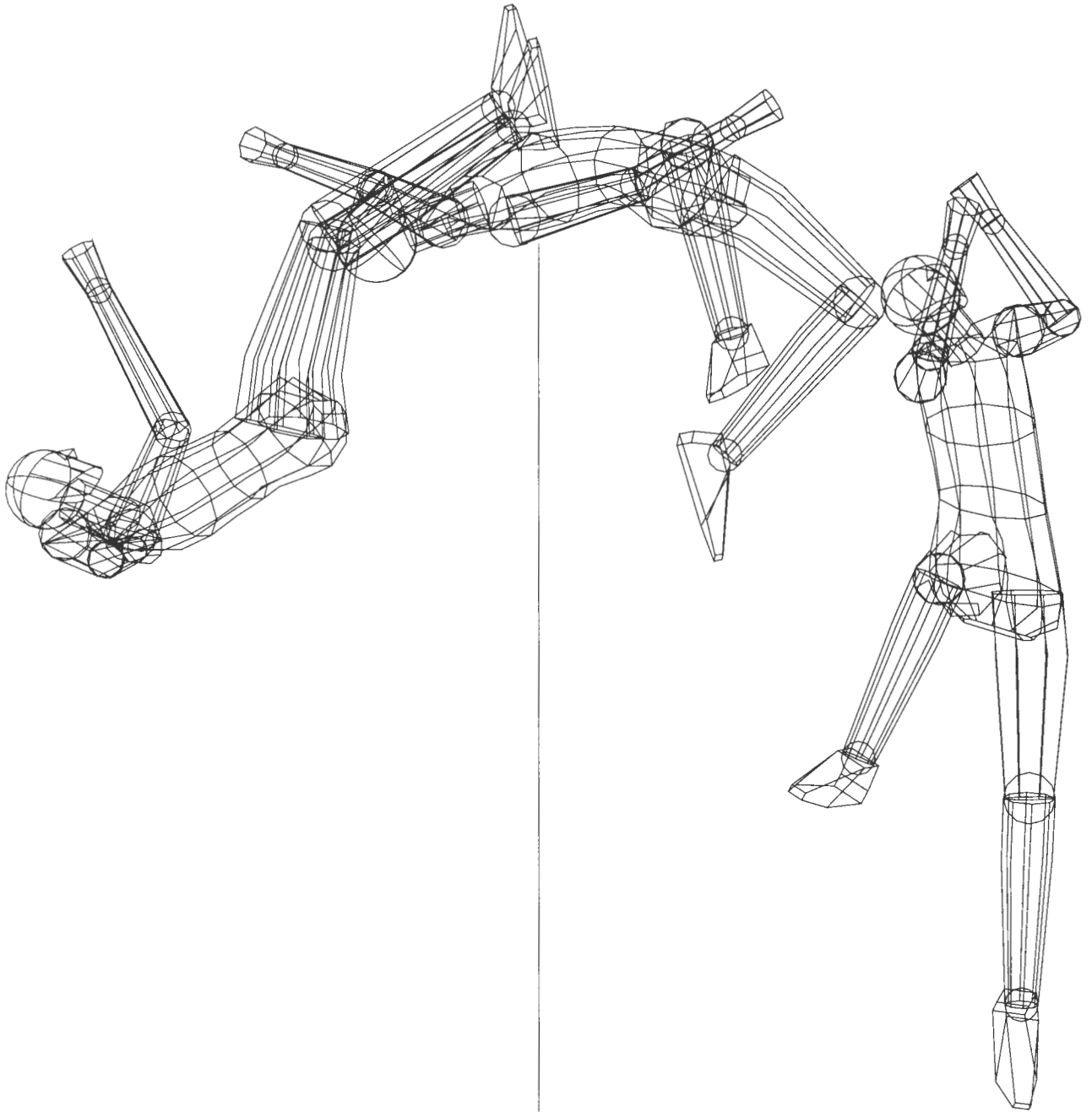

MOFFATT #84 062407 2.24 M CLEARANCE

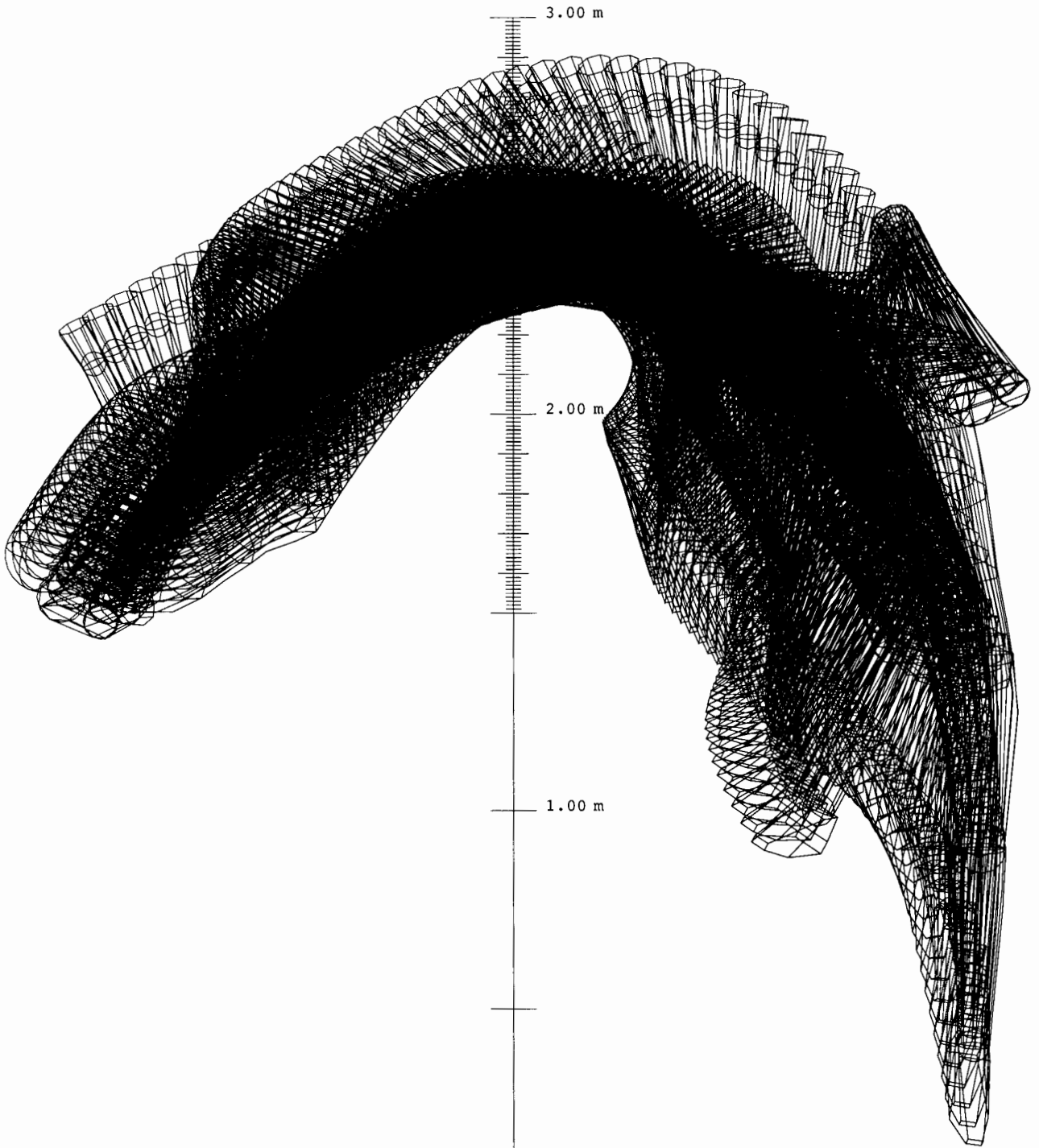

MOFFATT #84 062407 2.24 M CLEARANCE

Jamie NIETO

Jump 99 was Nieto's last successful clearance in the "administrative tiebreaker" to decide 2nd place at the 2007 USATF Championships (2.25 m).

Based on Nieto's vertical velocity at takeoff in jump 99 ($v_{ZTO} = 4.30$ m/s), a technique of average quality would have included a c.m. height equal to about 47% of his own standing height at the end of the run-up, and a final run-up speed of about 7.4 m/s. Nieto's actual c.m. height and speed at the end of the run-up ($h_{TD} = 46.5\%$; $v_{H1} = 7.3$ m/s) were similar to those expected for a technique of average quality. Therefore, the overall combination of final run-up speed and c.m. height that Nieto used in jump 99 was not very bad, but also not particularly good.

At the end of the run-up, Nieto planted the takeoff foot too parallel to the bar. Because of this, the angle between the longitudinal axis of the takeoff foot and the horizontal force received by the foot was extremely large ($e_3 = 52^\circ$). This would normally lead us to predict a very large risk of foot pronation, and injury to the ankle and foot. (See the section on "Orientation of the takeoff foot, and potential for ankle and foot injuries" in the main text of the report.) However, through direct viewing of the videos we noticed that there was only a moderate amount of pronation in Nieto's jumps. (See the images on this page.)

Nieto's arm actions during the takeoff phase were strong (AAT = 17.3 mm/m), and the action of his lead leg was somewhat weak (LLA = 18.1 mm/m). In consequence, the overall combination of Nieto's arm and lead leg actions in jump 99 was somewhat weak (FLA = 35.4 mm/m). This was not quite as good as in 2004, but better than in any other of Nieto's previous analyzed jumps.

Nieto had only a small amount of backward lean at the start of the takeoff phase in jump 99 (BFTD = 82°). Then he rotated forward during the takeoff phase, and at the end of the takeoff he was essentially vertical (BFTO = 89°). A problem with this was that, due to his small amount of backward lean at the start of the takeoff phase, Nieto did not rotate forward through a large enough angle during the takeoff phase. This limited to a somewhat small value the amount of forward somersaulting angular momentum that he was able to generate ($H_F = 65$).

Nieto's trunk had a very good lean toward the right at the start of the takeoff phase (LRTD = 73°). Then his trunk rotated toward the left during the

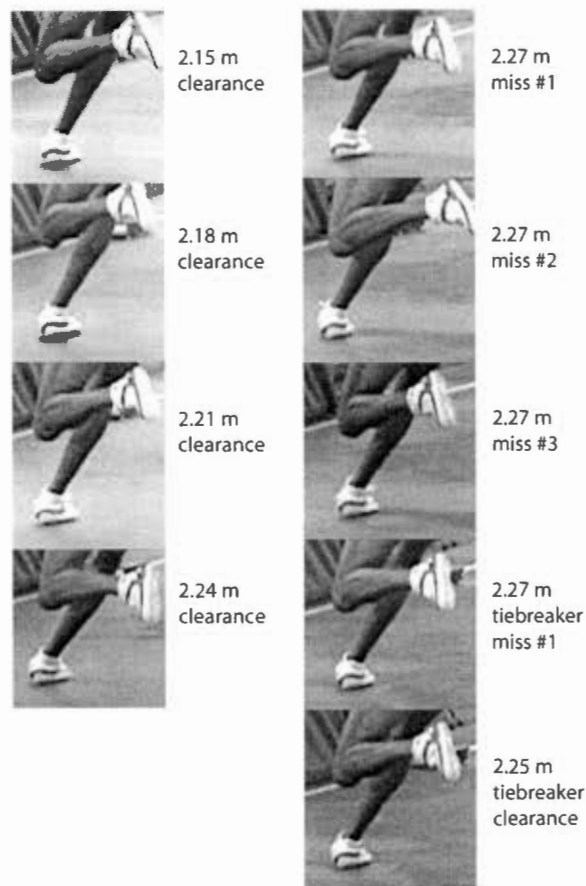

takeoff phase, and it was 7° beyond the vertical by the end of the takeoff (LRTO = 97°). In the view from the back, it's normal for high jumpers to go up to 10° past the vertical at the end of the takeoff. This seems to provide an optimum compromise between the generation of lift and the generation of enough lateral somersaulting angular momentum to permit a good rotation over the bar. Therefore, Nieto's position at the end of the takeoff was quite good. His large amount of rotation toward the left during the takeoff phase allowed him to generate a good amount of lateral somersaulting angular momentum ($H_L = 100$).

Nieto's somewhat small amount of forward somersaulting angular momentum and large amount of lateral somersaulting angular momentum combined into a somewhat small total amount of somersaulting angular momentum ($H_S = 115$).

Nieto's c.m. reached a maximum height $h_{PK} = 2.30$ m in jump 99. The "saturation graph" shows that in this jump he could have cleared cleanly a bar set at about $h_{CLS} = 2.28$ m, and at $h_{CLA} = 2.29$ m if he had taken off slightly farther from the plane of the bar and the standards. In relation to the peak height

of the c.m. (2.30 m), the 2.29 m clean clearance height indicated a very effective bar clearance. This had particular merit in view of the fact that Nieto's total amount of somersaulting angular momentum was somewhat small.

Overall, Nieto's leans at the plant and at the end of the takeoff, his generation of angular momentum, and his bar clearance were very good.

Recommendations

The main problem in Nieto's technique was his combination of speed and c.m. height at the end of the run-up. He needs to be faster and/or lower than in jump 99. The optimum combination for any jumper is faster and/or lower than the expected average ("ordinary") combination. In terms of Figure 3, all solutions to this problem involve moving Nieto's point to the diagonal line recommended for $v_{ZTO} = 4.30$ m/s. One possible option would be to combine the height that Nieto had at the end of the run-up in jump 99 ($h_{TD} = 46.5\%$) with a much faster speed ($v_{HI} = 7.7-7.8$ m/s). (See the horizontal arrow in the graph shown in this page.) This larger amount of final run-up speed should allow Nieto to generate more lift during the takeoff phase, and thus to produce a larger height for his c.m. at the peak of the jump. (See Appendix 2 for exercises that will help to produce fast and low conditions at the end of the run-up.)

An alternative option would be to put the c.m. at the end of the run-up in a lower position, equivalent to about 45.5% of Nieto's own standing height. This would be a final run-up height similar to those used by Nieto in jumps 36 and 13 from 2001/2002. With such a position at the end of the run-up, a final horizontal speed of about 7.6 m/s would be sufficient to qualify as optimal. (See the arrow pointing downward and toward the right in the graph.)

(Standard caution when increasing the run-up speed and/or lowering the c.m. height at the end of the run-up: The use of a faster and/or lower run-up will put a greater stress on the takeoff leg, and thus it may increase the risk of injury if the leg is not strong enough. Therefore, it is always

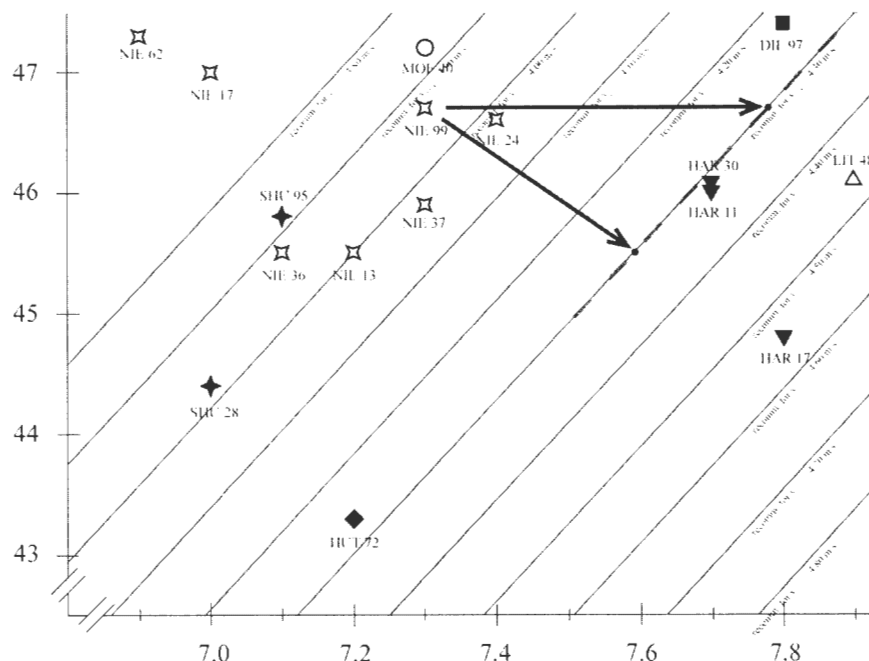

important to use caution in the adoption of a faster and/or lower run-up. If the desired change is very large, it would be advisable to make it gradually, over a period of time. In all cases, it may be wise to further strengthen the takeoff leg, so that it can withstand the increased force of the impact produced when the takeoff leg is planted.)

In spite of the very large angle between the longitudinal axis of Nieto's takeoff foot and the horizontal force received by the foot (angle e_3), direct observation of the videotape images indicate that Nieto's ankle only experienced a moderate amount of pronation. Angle e_3 is not the only factor that determines the amount of pronation, and it may be that Nieto's ankle musculature is strong enough to control the amount of pronation of the foot in spite of the very large e_3 angle. We still think it would be good for Nieto to plant the takeoff foot on the ground in a more counterclockwise orientation, with the toe pointing more toward the landing pit than in jump 99. However, due to the information gleaned from Nieto's video images, we are not as concerned about Nieto's ankle as we were in previous reports.

Nieto's arm and lead leg actions in jump 99 were overall somewhat weak, but this was not a very important problem. The problem would be completely eliminated if Nieto lifted his left knee a little bit higher at the end of the takeoff phase.

No changes should be made in Nieto's leans at the start and at the end of the takeoff phase, in his generation of angular momentum, nor in his actions

on top of the bar. These aspects of his technique are already very good.

NIETO #99 062407 2.25 M CLEARANCE

RUN-UP

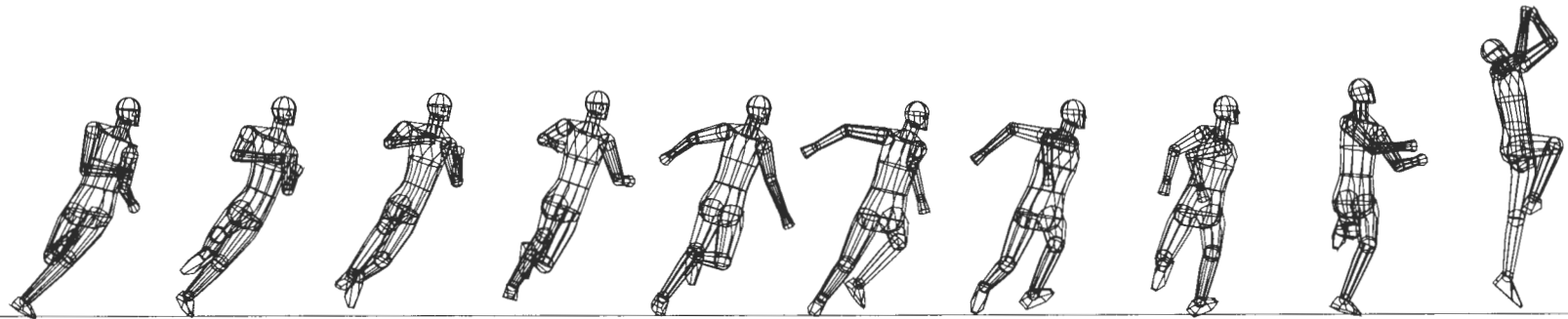
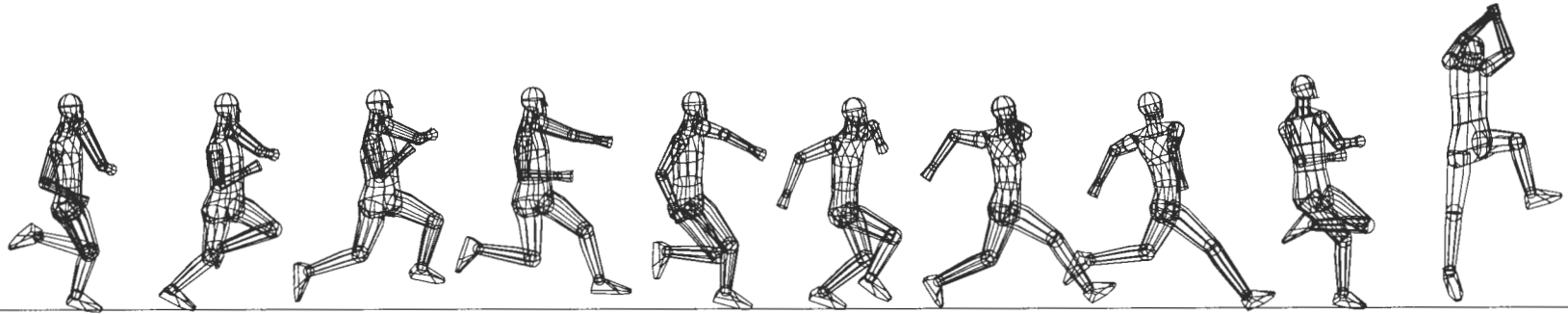

9.58

9.64

9.70

9.76

9.82

9.88

9.94

10.00

10.10

10.20

NIETO #99 062407 2.25 M CLEARANCE

TAKEOFF PHASE

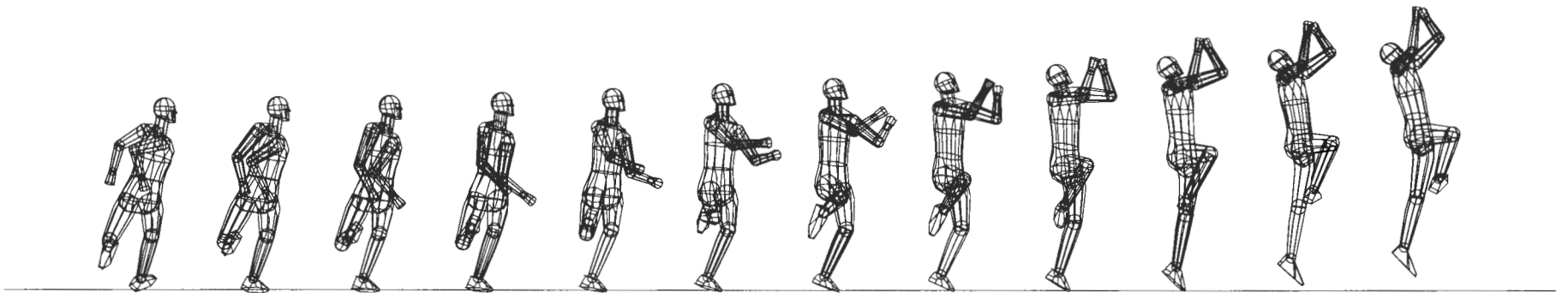
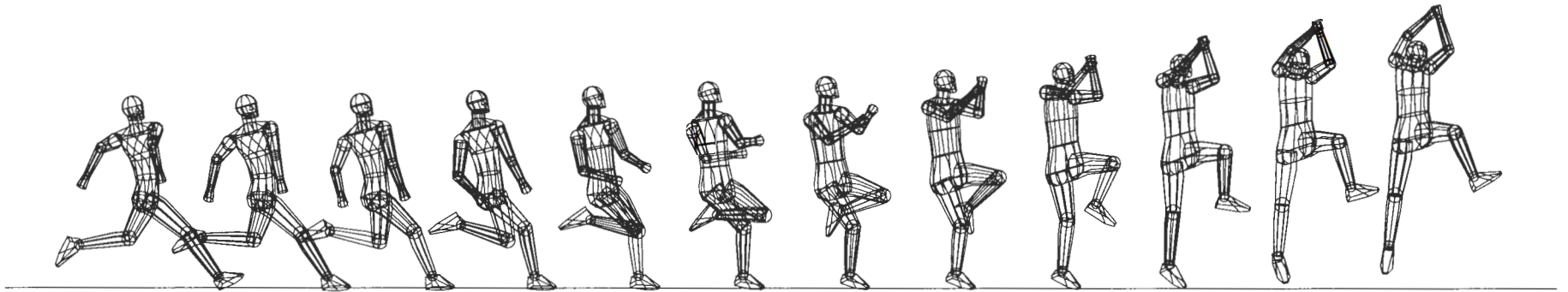

10.00

10.02

10.04

10.06

10.08

10.10

10.12

10.14

10.16

10.18

10.20

10.22

NIETO #99 062407 2.25 M CLEARANCE

BAR CLEARANCE

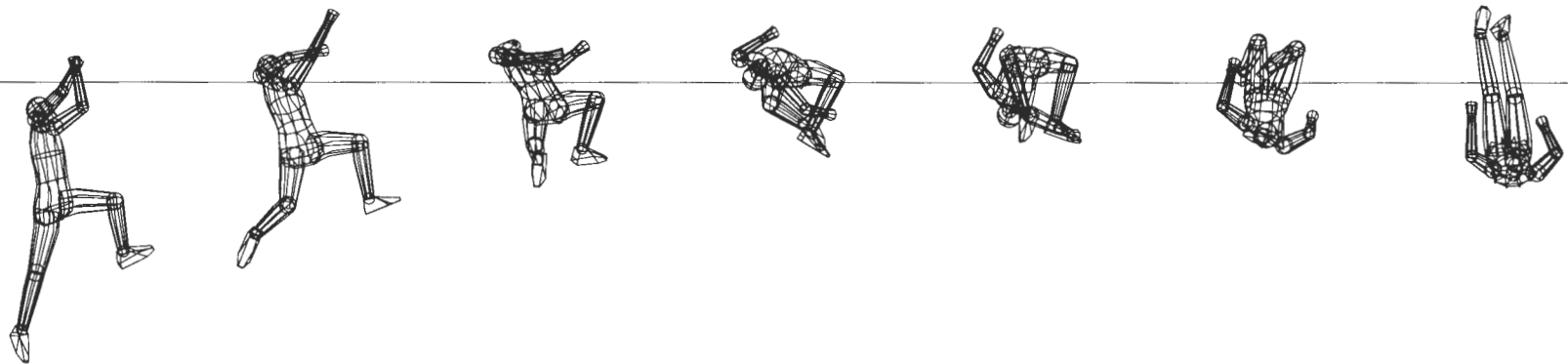
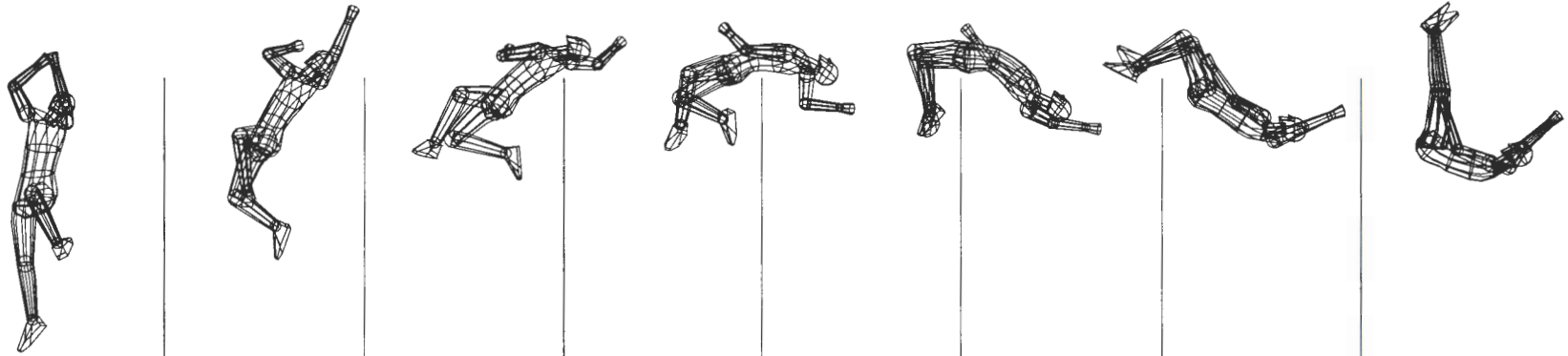

10.22

10.34

10.46

10.58

10.70

10.82

10.94

C.M. HEIGHT VS TIME

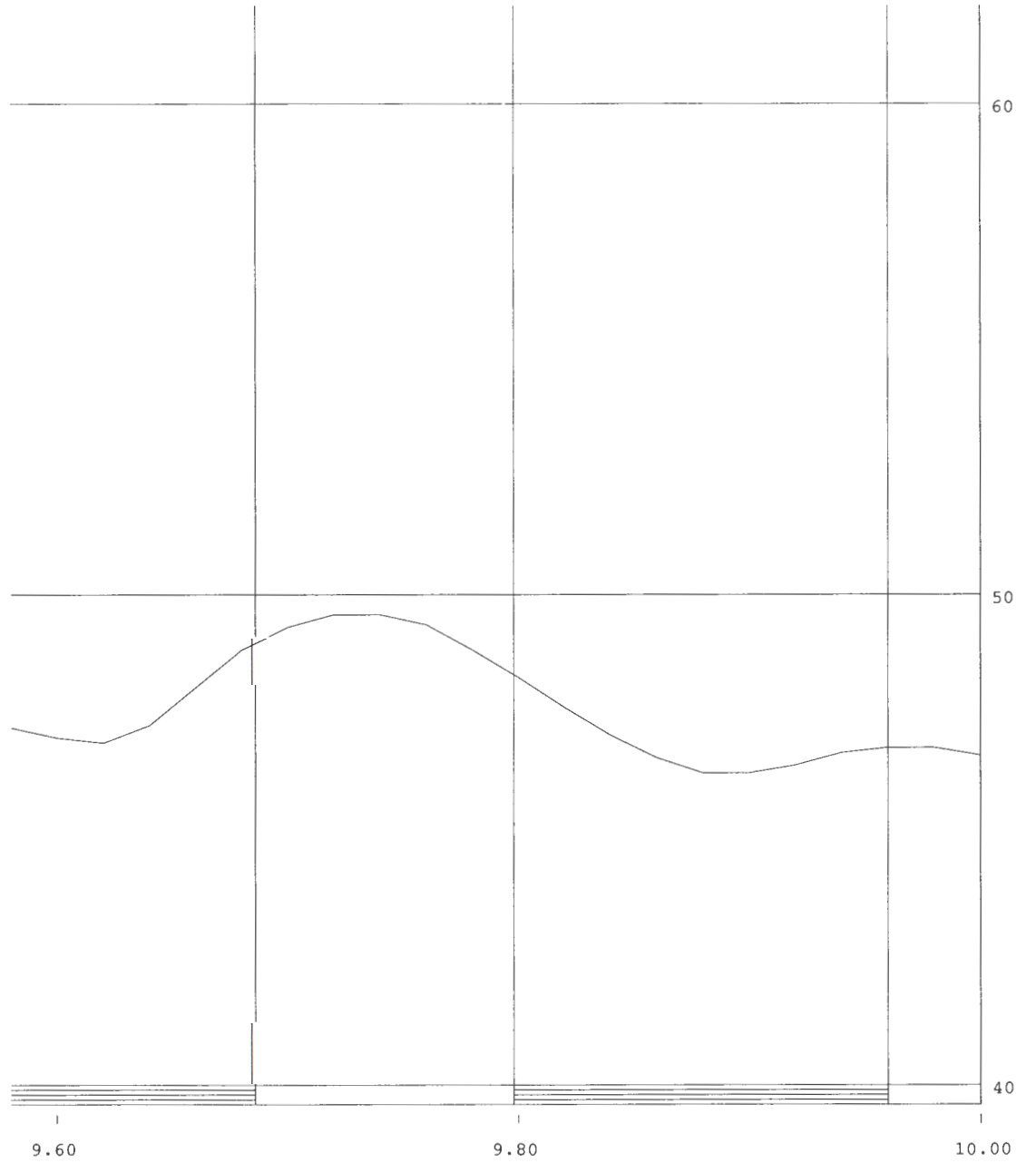

1
9.40

1
9.60

1
9.80

1
10.00

NIETO #99 062407 2.25 M CLEARANCE

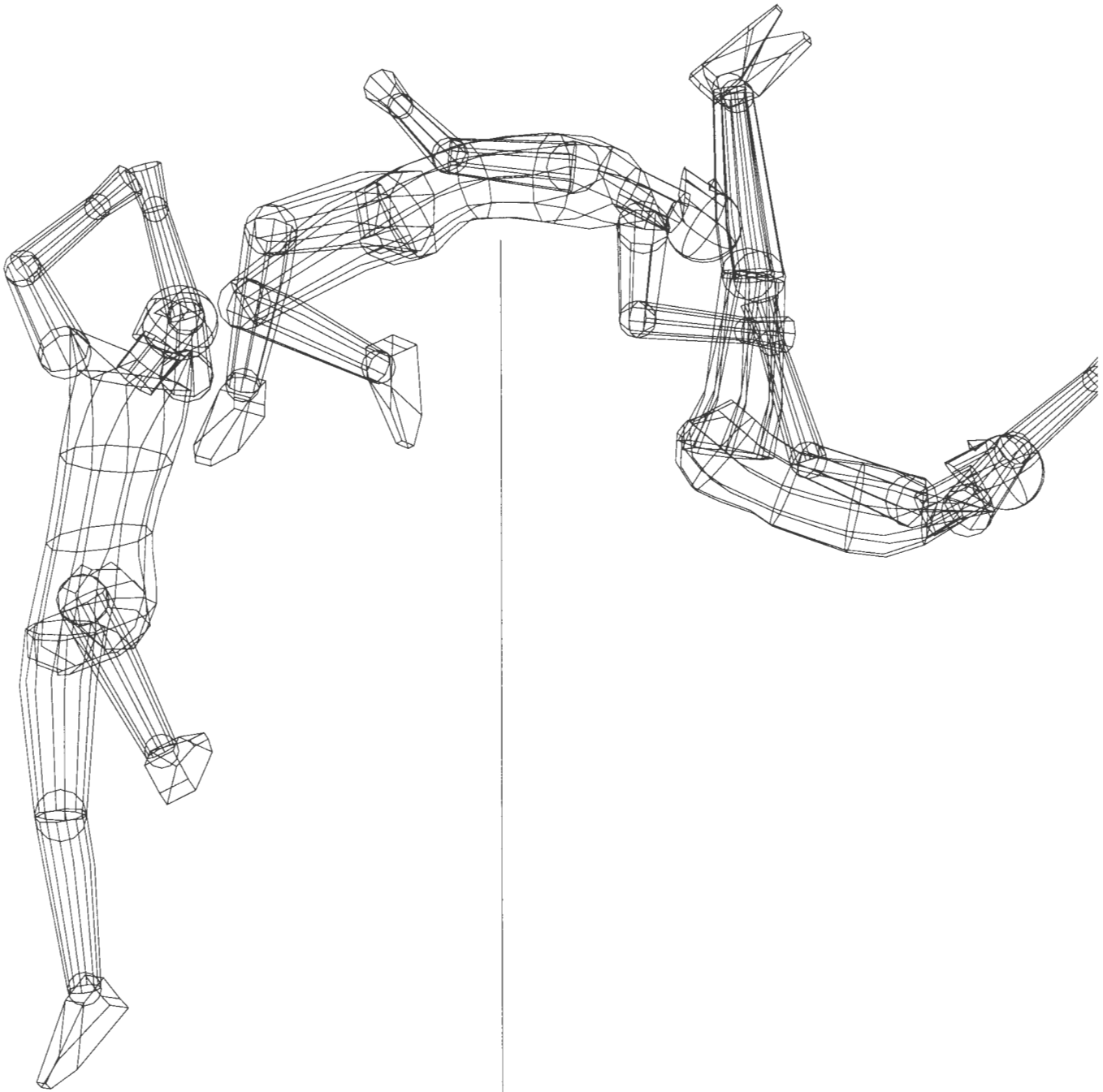

NIETO #99 062407 2.25 M CLEARANCE

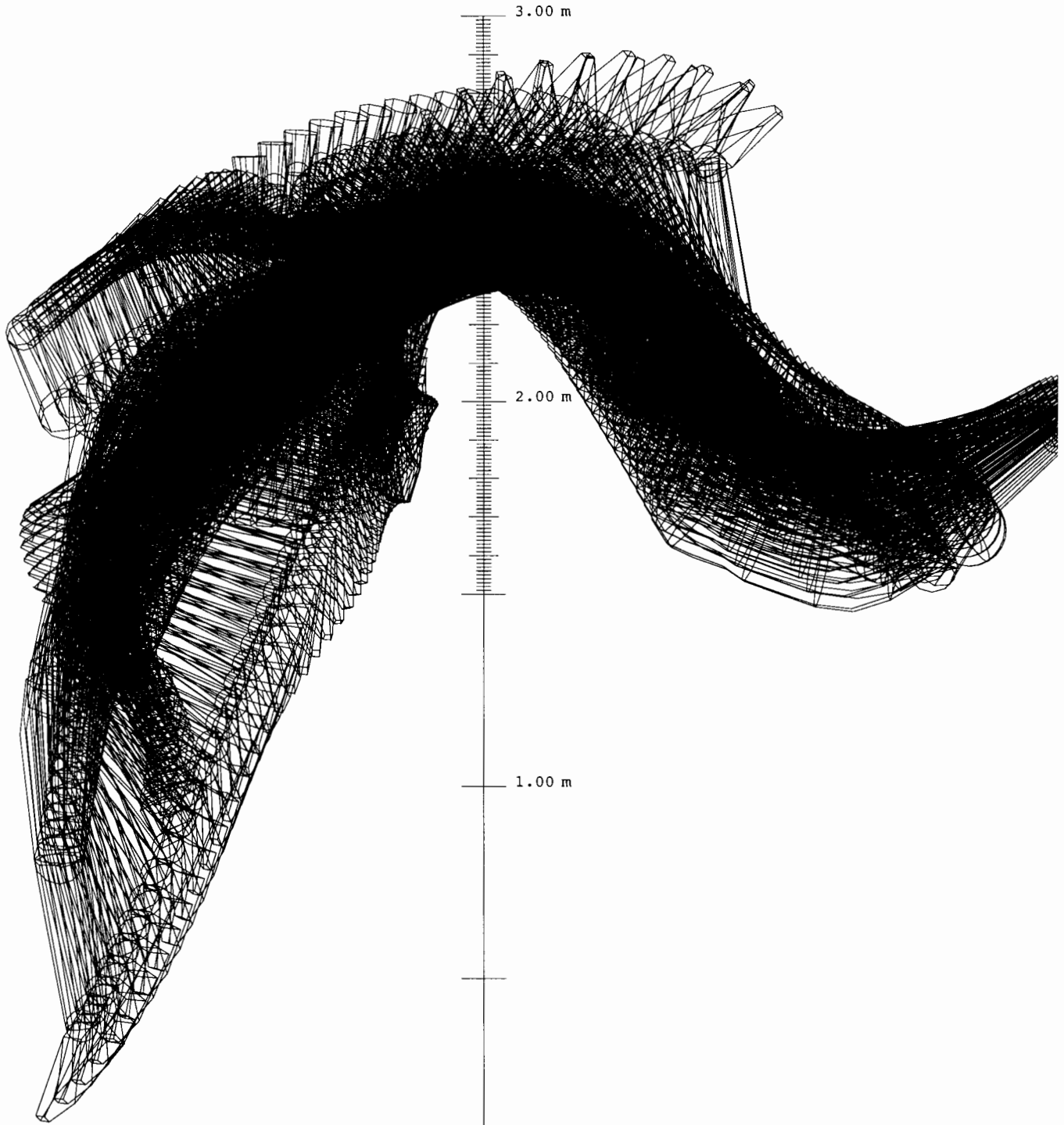

NIETO #99 062407 2.25 M CLEARANCE

Scott SELLERS

Jump 42 was Sellers' last successful clearance at the 2007 USATF Championships (2.18 m).

Sellers' vertical velocity at takeoff in jump 42 was $v_{ZTO} = 4.25$ m/s. However, the USATF Championships were a particularly bad competition for him, and thus Sellers' 4.25 m/s v_{ZTO} value presents a distorted view of his physical condition during the 2007 season. Sellers' best mark of the season was 2.33 m. Even though we have no hard data on his 2.33 m jump, we can estimate fairly accurately that he must have generated about 4.55 m/s of vertical velocity in that jump. Therefore, we will consider $v_{ZTO} = 4.55$ m/s the best indicator of Sellers' physical condition.

Based on a vertical velocity at takeoff of $v_{ZTO} = 4.55$ m/s, a technique of average quality would have included a final run-up speed of about 7.6 m/s and a c.m. height at the end of the run-up equal to about 46.5% of his own standing height. In jump 42, Sellers was actually slightly faster at the end of the run-up ($v_{HI} = 7.7$ m/s) than what would be expected in a technique of average quality, but his c.m. was also clearly higher ($h_{TD} = 48\%$). This was much worse than the 8.0/47.5 combination that he used in 2006, and a weak challenge for a high jumper with a takeoff leg capable of generating 4.55 m/s of vertical velocity. The wet conditions of the track in the 2007 competition may have played a role in this problem, but we don't know for sure.

The last step of Sellers' run-up was somewhat too long ($SL_1 = 2.09$ m, or 111% of his own standing height). This long length of the last step of the run-up probably contributed to Sellers' somewhat large negative vertical velocity at the start of the takeoff phase ($v_{ZTD} = -0.6$ m/s). A large negative v_{ZTD} value is not advisable, because it requires the athlete to make an extra effort to stop the downward motion before producing the needed upward vertical velocity.

At the end of the run-up, Sellers planted the takeoff foot at what we consider to be a very good orientation, not too parallel to the bar. As expected, the angle that this produced between the foot and the horizontal direction in which the foot pushed against the ground during the takeoff phase was small ($e_3 = 16^\circ$). (See the section on "Orientation of the takeoff foot, and potential for ankle and foot injuries" in the main text of the report.) This was similar to Sellers' e_3 angle value from 2006, and we would expect such a small e_3 angle to produce a very safe takeoff,



without any pronation of the takeoff foot. However, it is possible that Sellers' ankle may not be as safe as it seems.

Until last year we recorded the jumps with movie cameras (16 mm film), and the images of the jumps were generally not clear enough to actually see the pronation of the foot during the takeoff phase. This year, we have switched to high definition video cameras, and the images are clearer. This sometimes allows us to see the pronation when it occurs. The images above show screen captures of Sellers' takeoff foot during the takeoff phase in jump 42. Even though this camera view is not the best for the observation of takeoff foot pronation, some pronation is evident: The outside edge of the shoe actually lifted off from the ground between the middle image and the image on the left, and other jumps by Sellers during the competition showed similar evidence of pronation. It is not clear to us why Sellers' foot pronated when his e_3 angle was so good. It is true that the amount of pronation does not seem very severe in these images, but we need to keep in mind that the images were not taken from the best viewpoint for the observation of pronation, so it is possible that the pronation might be more severe than what meets the eye.

Sellers' arm actions during the takeoff phase were very strong ($AAT = 21.4$ mm/m), and the action of his lead leg was also strong ($LLA = 20.9$ mm/m). Therefore, his overall combination of arm and lead leg actions was also strong ($FLA = 42.3$ mm/m). This was all very good.

In jump 42, Sellers' trunk had only a small amount of backward lean at the start of the takeoff phase ($BFTD = 79^\circ$). Then he rotated forward, and by the end of the takeoff his trunk was 2° beyond the vertical ($BFTO = 92^\circ$). In the view from the side, the trunk should be vertical (i.e., at 90°) at the end of the takeoff, so Sellers' overrotation probably produced a slight loss of lift. Also, due to Sellers' small amount of backward lean at the start of the takeoff phase, and in spite of the fact that he was slightly overrotated forward by the end of the takeoff phase, the amount of forward somersaulting angular momentum that he was able to generate was somewhat small ($H_F = 70$).

This limitation in the amount of angular momentum was ultimately due to Sellers' insufficient backward lean at the start of the takeoff phase.

Sellers' trunk had only a very small amount of lean toward the left at the start of the takeoff phase (LRTD = 84°). Then he rotated toward the right, and by the end of the takeoff he was 16° past the vertical in the view from the back (LRTO = 106°). In the view from the back, it's normal to go a few degrees past the vertical at the end of the takeoff. We consider it acceptable (indeed, desirable) to tilt up to 10° past the vertical at the end of the takeoff (in the view from the back) because we believe that this may be the best compromise between the generation of lift and the generation of rotation (angular momentum). However, in his quest for the generation of lateral somersaulting angular momentum, Sellers went well beyond the acceptable limit for lean toward the right by the end of the takeoff phase. This probably produced a sizable loss of lift for the jump. And still, he was only able to generate a small amount of lateral somersaulting angular momentum ($H_L = 75$). This limited amount of angular momentum, as well as the loss of lift associated with the excessive lean toward the right at the end of the takeoff, were both ultimately due to Sellers' insufficient lean toward the left at the start of the takeoff phase. The wet conditions of the track in the 2007 competition may have played a role in this problem: Did the wet track make it impossible to use a curve tight enough to produce the necessary amount of lean toward the left? We don't know.

Sellers' forward and lateral components of somersaulting angular momentum added up to a small total amount of somersaulting angular momentum ($H_S = 105$). This was the same amount that he generated in 2006, but in jump 42 from 2007 Sellers' leans backward and toward the left at the start of the takeoff phase were clearly worse (smaller) than in 2006. This resulted in larger leans forward and toward the right at the end of the takeoff, with consequently larger losses of lift.

The peak height reached by the c.m. in jump 42 was $h_{PK} = 2.24$ m. The "saturation graph" shows that in this jump Sellers could have cleared cleanly a bar set at about $h_{CLS} = 2.18$ m. In relation to the peak height of the c.m. (2.24 m), the 2.18 m clean clearance height indicated a bar clearance that was not very effective. The effectiveness of Sellers' bar clearance was similar to that of 2006. In part the problem was due, as in 2006, to Sellers' limited total amount of somersaulting angular momentum, but there were other complicating factors as well.

Sellers' marked lean toward the bar at the end of the takeoff put his shoulders in danger of hitting the bar on the way up, even with his limited amount of somersaulting angular momentum. This may have been what led him to adopt a rather unusual "sitting" body configuration on the way up to the bar. As the athlete gets into such a configuration the legs rotate counterclockwise (in the view from the left standard, along the bar) while the upper trunk rotates clockwise and the hips drop down. (See the graphic above.) This is a good maneuver that helps to keep the shoulders away from the bar. It is generally not necessary in normal jumps in which the athlete is closer to vertical at the end of the takeoff phase. (We assume that the purpose of this "sitting" body configuration used by Sellers was indeed to prevent the shoulders from hitting the bar, and not an attempt at implementing the "knee bending" maneuver that we proposed in the 2006 report. The maneuver that we proposed was to "bend the knees as if the athlete were trying to kick the bar from below with his heels", quite different from the "sitting" position described above, which Sellers used in all of his jumps at the 2007 meet.)

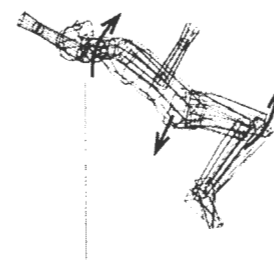

In jump 42, Sellers did not arch very much. The graphics below show his maximum arch in jump 03 from 2006 and in jump 42. (The image of jump 03 has been rotated counterclockwise to facilitate the comparison of arching.) The graphics show that Sellers used much less arching in jump 42 from 2007 than in jump 03 from 2006.

jump 03 from 2006

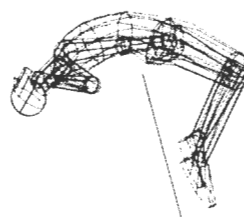

jump 42

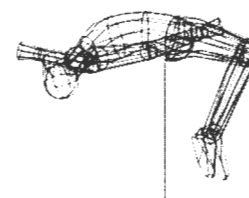

Recommendations

Sellers' technique was much worse in 2007 than in 2006. We do not know to what extent the problems were due to the slippery conditions of the track. (The track was wet in both meets, but it

seemed to dry off better toward the end of the meet in 2006 than in 2007.)

An important problem in Sellers' technique was his combination of speed and c.m. height at the end of the run-up. He needs to be faster and/or lower than in jump 42. The optimum combination for any jumper is faster and/or lower than the expected average ("ordinary") combination. In terms of Figure 3, all solutions to this problem involve moving Sellers' point to the diagonal line recommended for $v_{ZTO} = 4.55$ m/s. (See the graph on the right.) One possible option would be to combine the heights that Sellers had at the end of the run-up in jumps 03 or 42 with a much larger amount of speed than what Sellers had in jump 42. We would suggest for him a final speed of about 8.3 or 8.2 m/s. (See the horizontal arrow and the arrow that points slightly downward in the graph shown to the right of these lines.) These larger final speeds of Sellers' run-up should allow him to generate more lift during the takeoff phase, and thus to produce a larger height for his c.m. at the peak of the jump. (See Appendix 2 for exercises that will help to produce fast and low conditions at the end of the run-up.)

An alternative option would be to put the c.m. at the end of the run-up in a clearly lower position, equivalent, for instance, to about 46% of Sellers' own standing height. This would be a final run-up height similar to those used by Littleton or Shunk at the 2007 USATF Championships. With such a position at the end of the run-up, Sellers would not need to be traveling at 8.2/8.3 m/s at the end of the run-up for his technique to be considered optimum: A final horizontal speed of about 8.0 m/s would do. (See the arrow pointing steeply downward and toward the

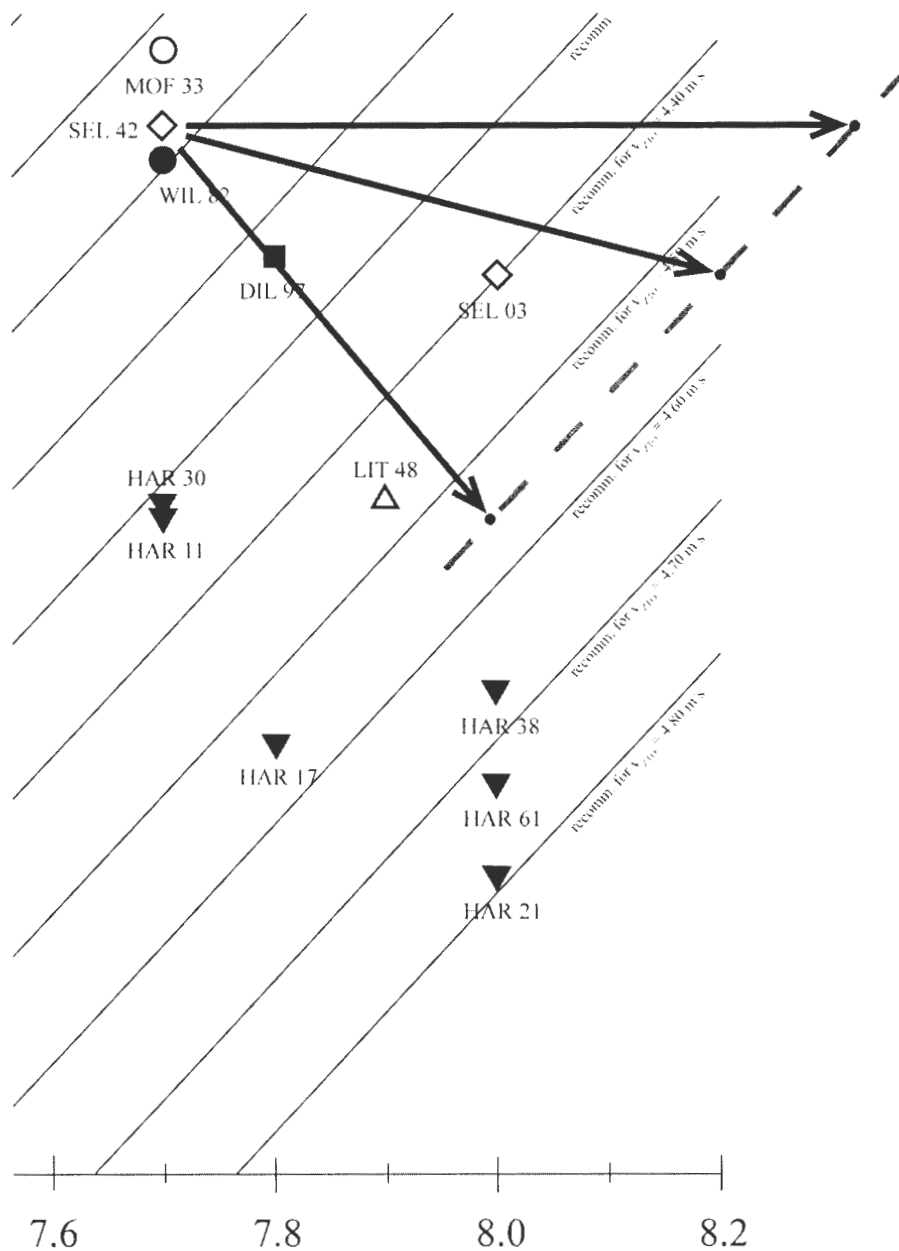

right in the graph above.)

These recommended combinations of speed and height at the end of the run-up are based on the use of average "run-of-the-mill" arm and lead leg actions during the takeoff phase. Athletes such as Sellers who use very strong arm and lead leg actions during the takeoff phase should compensate by using somewhat slower and/or higher run-ups; otherwise, the takeoff leg might buckle during the takeoff phase.

(Standard caution when increasing the run-up speed and/or lowering the c.m. height at the end of the run-up: The use of a faster and/or lower run-

up will put a greater stress on the takeoff leg, and thus it may increase the risk of injury if the leg is not strong enough. Therefore, it is always important to use caution in the adoption of a faster and/or lower run-up. If the desired change is very large, it would be advisable to make it gradually, over a period of time. In all cases, it may be wise to further strengthen the takeoff leg, so that it can withstand the increased force of the impact produced when the takeoff leg is planted.)

The most important problem in Sellers' technique was probably the minimal amount of lean that he had toward the left at the start of the takeoff phase. (See the back views of his run-up sequence or of his takeoff sequence at $t = 10.00$ s.) It led him to acquire a very large lean of his trunk toward the right at the end of the takeoff phase (see the back view of the takeoff sequence at $t = 10.18$ s), which in turn led to a large loss of lift. The faster run-up speed that we propose for Sellers should help to produce a slight increase in his lean toward the left at the end of the run-up. However, to acquire the necessary amount of lean he will probably also have to tighten the run-up curve, i.e., to use a curve with a shorter radius. See Appendix 4 for more information on how to change the shape of the run-up curve.

A smaller problem is Sellers' insufficient backward lean at the start of the takeoff phase. He should thrust his hips further forward in the very last step of the run-up. This will give his trunk a larger amount of backward lean at the start of the takeoff phase. Then, he should allow his trunk to rotate forward during the takeoff phase, but only up to the vertical by the end of the takeoff. This should produce a larger amount of forward somersaulting angular momentum, while avoiding any loss of lift that might have been produced through excessive forward lean at the end of the takeoff.

Another small problem was the rather long length of Sellers' last step of the run-up. To correct this, he should try to increase the tempo of the last two foot landings, i.e., he should try to plant the left foot on the ground almost immediately after he plants the right foot. By increasing the tempo of the last two foot landings, Sellers should be able to reduce the length of the last step of the run-up, but more importantly, he will reduce the time that he spends in the air during that step. This will prevent him from accumulating too much downward (negative) vertical velocity in the air, so that he does not have an excessively large downward vertical velocity when he plants the left foot on the ground to start the takeoff phase.

As explained before, we do not know why Sellers' takeoff foot pronated, when it had such a good orientation during the takeoff phase. Maybe the muscles that fight against pronation are weak in relation to the other muscles of his takeoff leg. Or he might have flat feet, although we think that this is unlikely. We also are not sure how severe the amount of pronation is. In any case, it may not be a bad idea to have Sellers be examined by a physician or a physical therapist. Maybe there is nothing wrong with his foot or ankle, but maybe there is, and an orthotic might help to protect against injury.

Sellers' arm and lead leg actions during the takeoff phase were very good. No changes are needed this aspect of his technique. In fact, as mentioned above, Sellers' free limb actions were so strong that, for optimum technique, he should probably use a slightly slower and/or higher run-up than what was recommended in the previous page.

In the air, our advice to Sellers is to implement the airborne actions proposed in the 2006 report: He should bend the knees as if he were trying to kick the bar from below with his heels. (See the 2006 report for further details.)

In summary, Sellers should use a faster and/or lower run-up. He should also tighten (i.e., shorten) the radius of his curve, and he should thrust his hips further forward in the last step of the run-up. This will produce good leans toward the left and backward at the start of the takeoff phase. He should try to plant the takeoff foot on the ground immediately after he plants the right foot on the ground. Then he should rotate during the takeoff phase forward all the way to the vertical, and toward the right to a position no more than 10° beyond the vertical in the view from the back. By doing this, he will generate a good amount of somersaulting angular momentum without losing any lift. In the air, he needs to implement the airborne actions proposed in the 2006 report (including the bending of the knees as if he were trying to kick the bar from below with his heels: mimic the actions of simulation #2 from the 2006 report). No changes should be made in Sellers' arm or lead leg actions during the takeoff phase, because they are already very good. It may be a good idea to get his takeoff foot examined by a physician or a physical therapist—maybe there isn't anything wrong with it, but maybe there is.

SELLERS #42 062407 2.18 M CLEARANCE

RUN-UP

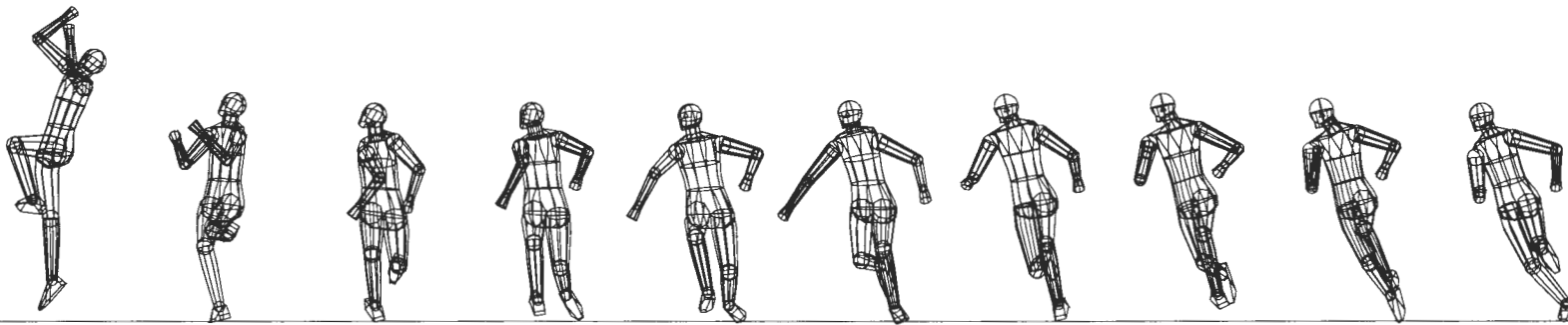
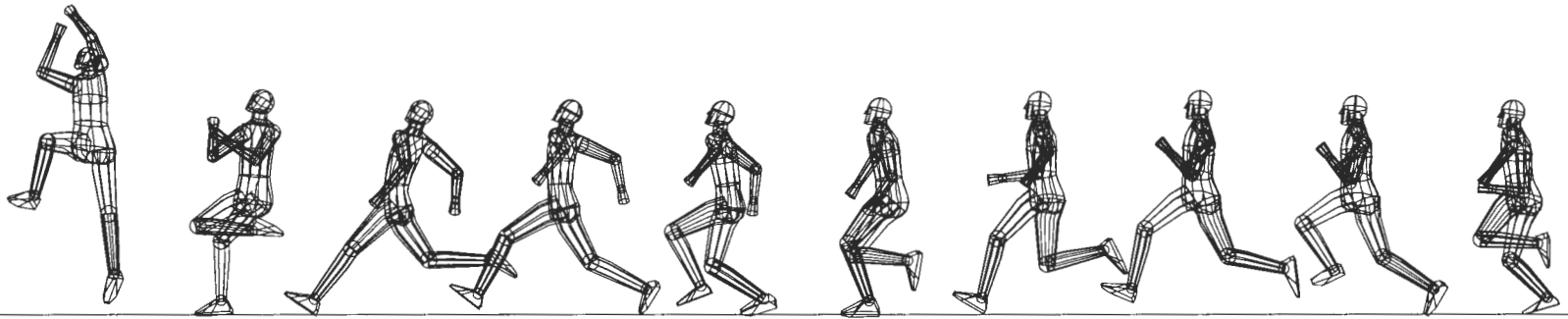

10.20

10.10

10.00

9.94

9.88

9.82

9.76

9.70

9.64

9.58

SELLERS #42 062407 2.18 M CLEARANCE

TAKEOFF PHASE

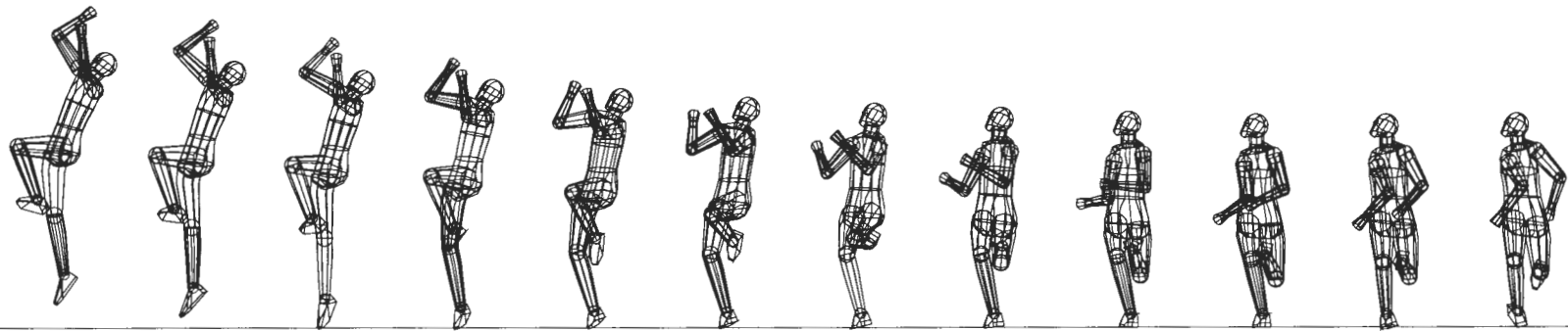
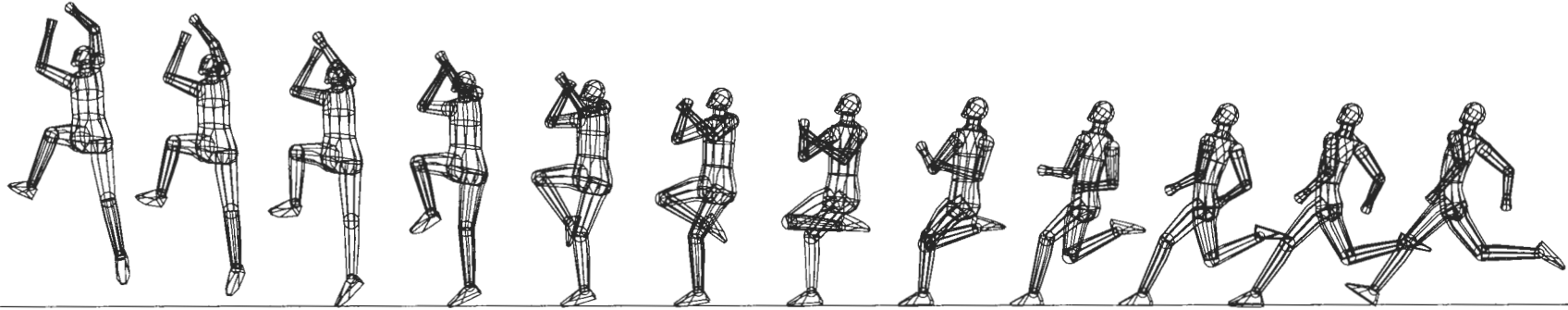

10.22

10.20

10.18

10.16

10.14

10.12

10.10

10.08

10.06

10.04

10.02

10.00

SELLERS #42 062407 2.18 M CLEARANCE

BAR CLEARANCE

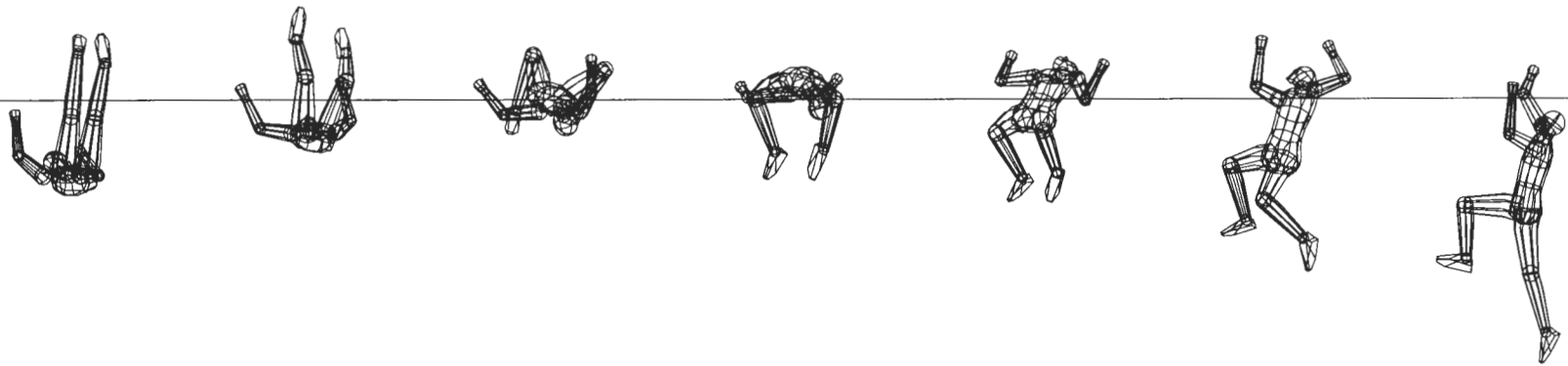
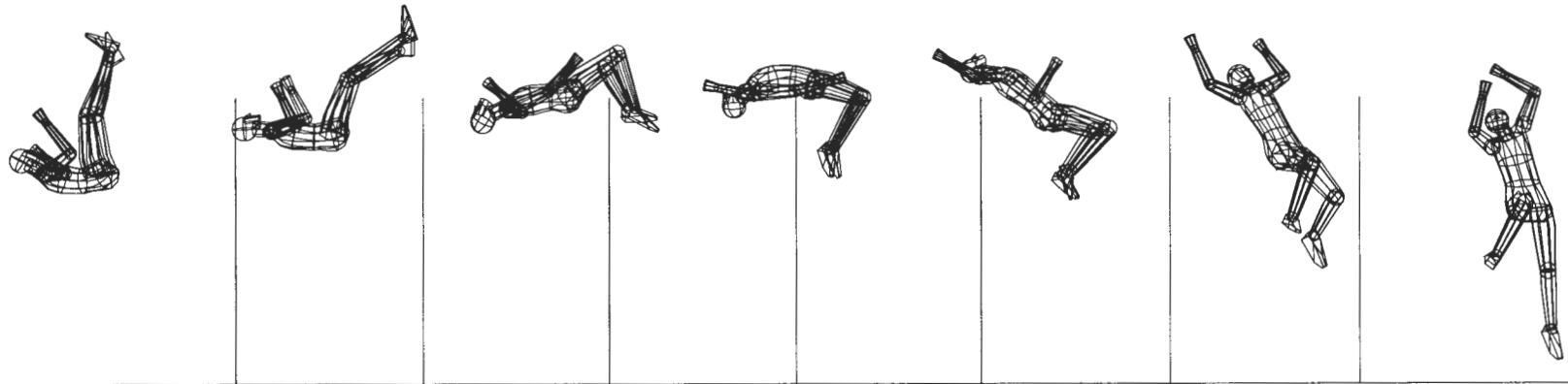

10.94

10.82

10.70

10.58

10.46

10.34

10.22

C.M. HEIGHT VS TIME

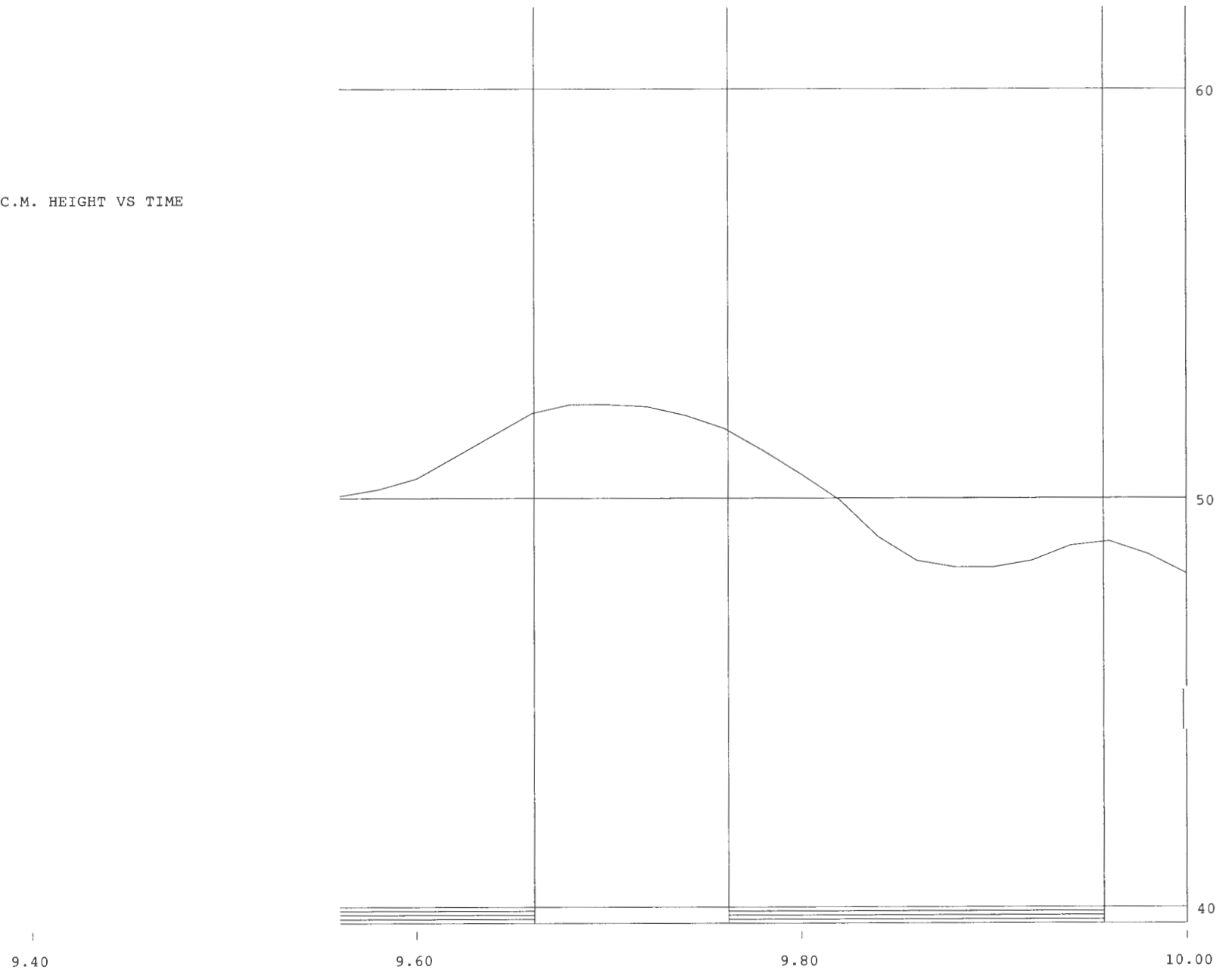

SELLERS #42 062407 2.18 M CLEARANCE

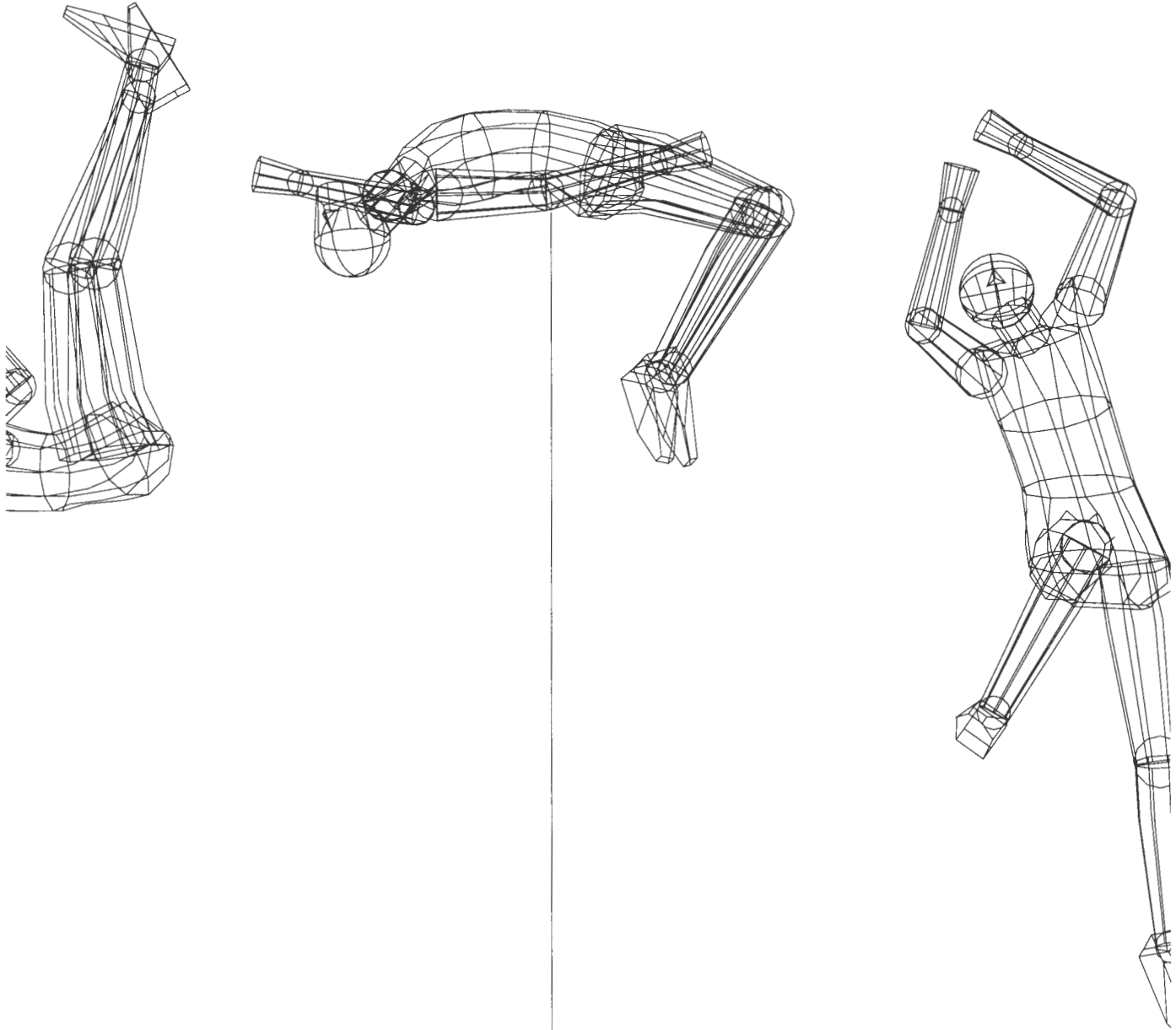

SELLERS #42 062407 2.18 M CLEARANCE

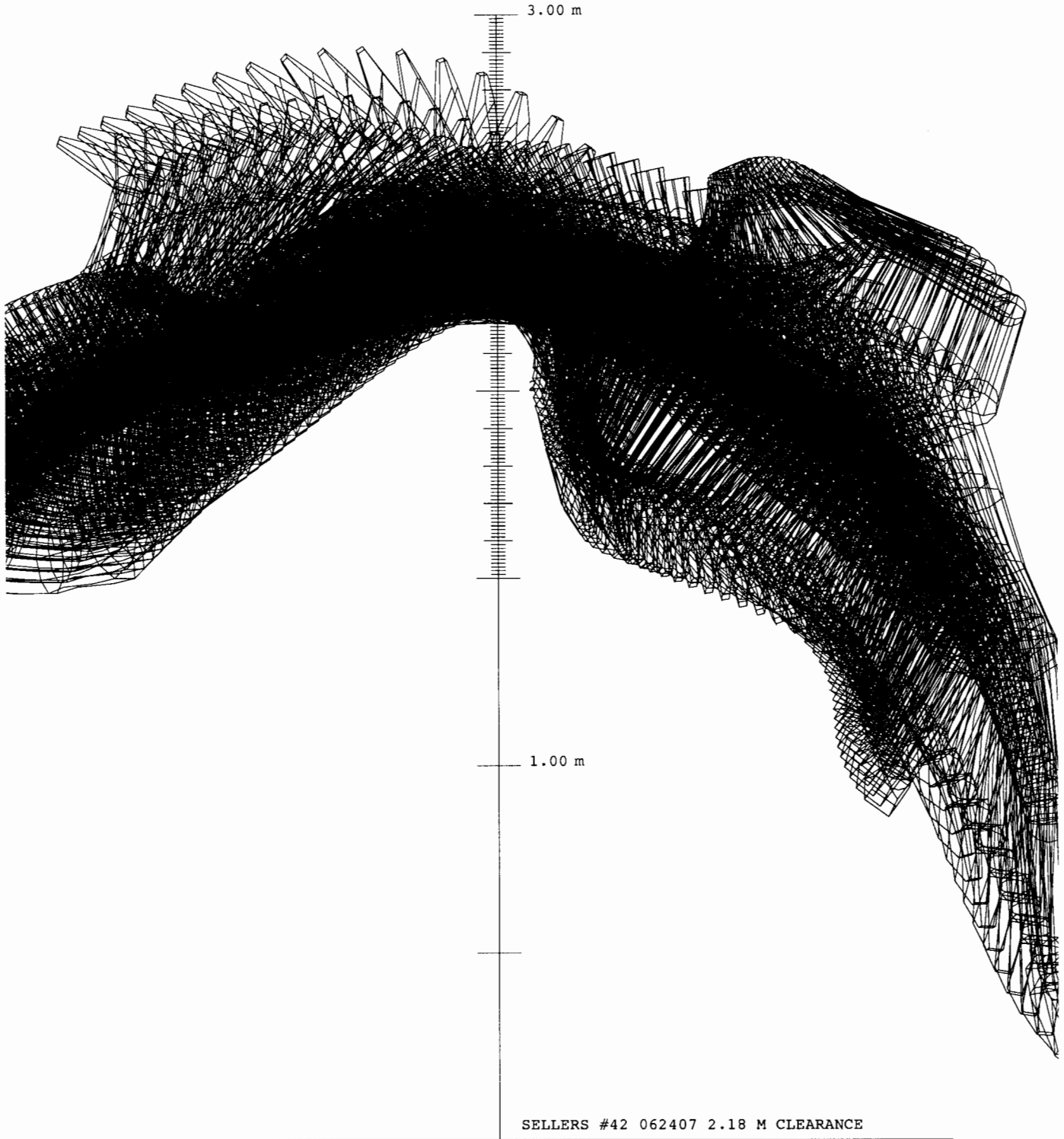

SELLERS #42 062407 2.18 M CLEARANCE

Adam SHUNK

Jump 95 was Shunk's 2nd attempt at 2.27 m at the 2007 USATF Championships. It was a close miss, and probably his best jump of the day.

Based on Shunk's vertical velocity at takeoff in jump 95 ($v_{ZTO} = 4.40$ m/s), a technique of average quality would have included a final run-up speed of about 7.5 m/s and a c.m. height at the end of the run-up equal to about 47% of his own standing height. Shunk was actually in a slightly lower position at the end of the run-up than what would be expected for a technique of average quality ($h_{TD} = 46\%$), but he was also very slow ($v_{H1} = 7.1$ m/s). Overall, the combination of run-up speed and c.m. height that Shunk used in jump 95 was a weak challenge for a high jumper with a takeoff leg capable of generating 4.40 m/s of vertical velocity. Shunk actually had a good amount of speed in the next-to-last step of the run-up ($v_{H2} = 7.7$ m/s), but lost a lot of it (0.6 m/s) as he passed over the right foot.

At the end of the run-up, Shunk planted the takeoff foot too parallel to the bar. Because of this, the angle between the longitudinal axis of the takeoff foot and the horizontal force received by the foot was very large ($e_3 = 43^\circ$). This produced a very large risk of ankle pronation, and injury to the ankle and foot. (See the section on "Orientation of the takeoff foot, and potential for ankle and foot injuries" in the main text of the report.)

Shunk's arm actions during the takeoff phase were strong (AAT = 16.1 mm/m). However, the action of his lead leg was somewhat weak (LLA = 16.9 mm/m). Because of this, his overall combination of arm and lead leg actions was somewhat weak (FLA = 33.0 mm/m).

Shunk's trunk had a good backward lean at the start of the takeoff phase (BFTD = 73°). But then he did not rotate forward enough during the takeoff phase, and at the end of the takeoff he was still far from the vertical in the view from the side (BFTO = 81°). Because of this, the amount of forward somersaulting angular momentum that Shunk was able to generate was small ($H_F = 55$).

Shunk's trunk had a very good lean toward the left at the start of the takeoff phase (LRTD = 74°). Then, he rotated toward the right, and by the end of the takeoff he was 10° past the vertical in the view from the back (LRTO = 100°). In the view from the back, it's normal to go a few degrees past the vertical

at the end of the takeoff. We consider it acceptable (indeed, desirable) to tilt up to 10° past the vertical at the end of the takeoff phase (in the view from the back) because we believe that this may be the best compromise between the generation of lift and the generation of rotation (angular momentum). So Shunk's left/right lean angles at the start and at the end of the takeoff phase were both very good. This allowed him to generate a large amount of lateral somersaulting angular momentum during the takeoff phase ($H_L = 95$).

Shunk's forward and lateral components of somersaulting angular momentum added up to a somewhat small total amount of somersaulting angular momentum ($H_S = 110$).

The peak height reached by the c.m. in jump 95 was $h_{PK} = 2.27$ m. The "saturation graph" shows that in this jump Shunk could have cleared cleanly a bar set at about $h_{CLS} = 2.23$ m, and at $h_{CLA} = 2.28$ m if he had taken off about 5 cm farther from the plane of the bar and the standards. In relation to the peak height of the c.m. (2.27 m), the 2.28 m clean clearance height indicated an extremely effective bar clearance. Considering that Shunk's angular momentum was somewhat small, this indicated that his actions in the air were exceptionally good.

Recommendations

Shunk had two main problems in his technique. The first one was his combination of speed and c.m. height at the end of the run-up. The optimum combination for any jumper is faster and/or lower than the expected average ("ordinary") combination. Although Shunk was in a reasonably low position at the end of the run-up, his final run-up speed was not fast enough. There are several ways in which Shunk can solve this problem. In terms of Figure 3, all options involve moving his point to the diagonal line recommended for $v_{ZTO} = 4.40$ m/s. (See the graph in the next page.) One possible option would be to combine the reasonably good (low) height that Shunk already had at the end of the run-up in jump 95 with a much larger amount of speed. We would suggest for him a final speed of about 7.8 m/s. (See the horizontal arrow in the graph shown in the next page.) To achieve this, Shunk would not actually have to run faster during the entire final part of the run-up. He already has a good amount of speed in the next-to-last step of the run-up ($v_{H2} = 7.7$ m/s), so he just needs to concentrate on not losing any of this speed as he passes over the last support on his right foot. For this, Shunk needs to try to pull backward harder on the ground with his right foot. A larger

final speed of his run-up should allow Shunk to generate more lift during the takeoff phase, and thus to produce a larger height for his c.m. at the peak of the jump. (See Appendix 2 for exercises that will help to produce fast and low conditions at the end of the run-up.)

An alternative option would be to put the c.m. in a slightly lower position, similar to the lower height that Shunk had at the end of the run-up in jump 28 from 2004. If Shunk is able to achieve this, he would not need to be traveling at 7.8 m/s at the end of the run-up for his technique to be considered optimum: A final horizontal speed of 7.5 m/s would do. (See the arrow pointing downward and toward the right in the graph on this page.)

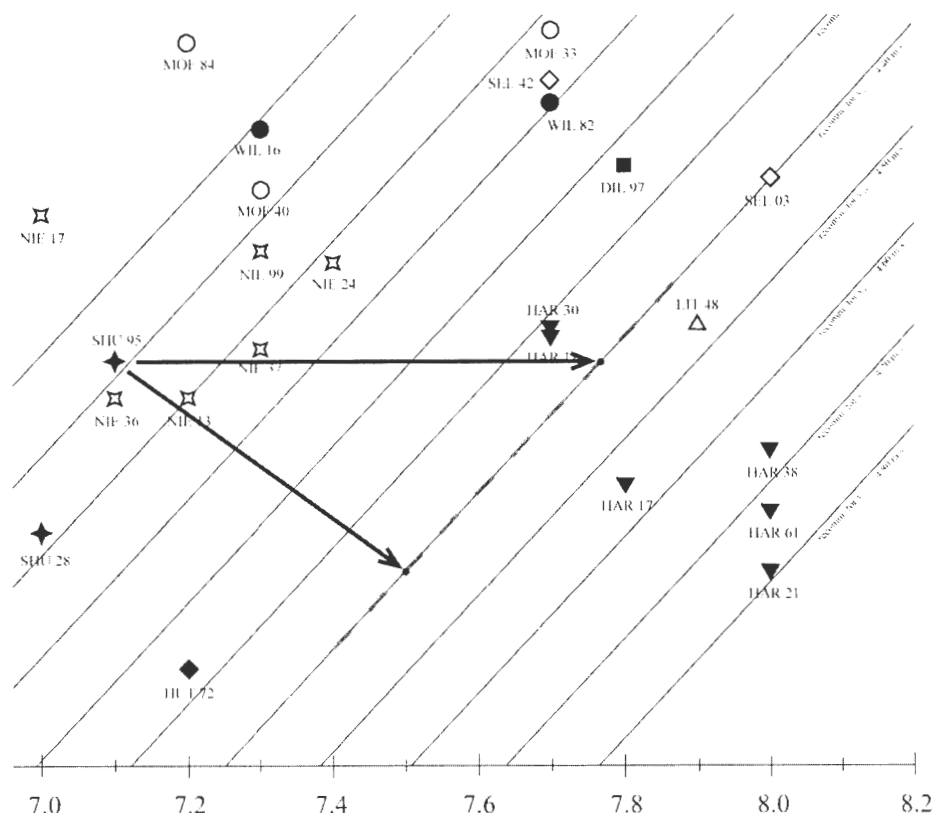

(Standard caution when increasing the run-up speed and/or lowering the c.m. height at the end of the run-up: The use of a faster and/or lower run-up will put a greater stress on the takeoff leg, and thus it may increase the risk of injury if the leg is not strong enough. Therefore, it is always important to use caution in the adoption of a faster and/or lower run-up. If the desired change is very large, it would be advisable to make it gradually, over a period of time. In all cases, it may be wise to further strengthen the takeoff leg, so that it can withstand the increased force of the impact produced when the takeoff leg is planted.)

The second major problem in Shunk's technique was the orientation of the left foot during the takeoff phase. He planted the takeoff foot too parallel to the bar. Based on this, we advise him to plant the takeoff foot on the ground with its longitudinal axis more in line with the final direction of the run-up, with the toe pointing at least 25° more clockwise than in jump 95. This technique change will help to prevent foot pronation, and injury to the ankle and foot.

In the past, to advise high jumpers about the appropriate orientation of the takeoff foot, we relied

exclusively on the orientation of the takeoff foot relative to the direction of the horizontal force made by the athlete on the ground during the takeoff phase (angle e_3). This was because it was almost never possible to actually see the foot pronation in the images of the 16 mm movie film that we used. This has changed to some extent with our switch to high definition video. The images are much clearer, and we have a better chance of actually seeing the pronation in the video images. For athletes who approach from the left, we can generally see the pronation quite well if it occurs. Unfortunately, for athletes who approach from the right (like Shunk), it is not so easy to see, due to the positions in which we have to place our cameras. Still, we were able to detect pronation in most of Shunk's jumps. The two series of images in the next page show the takeoff foot in two of Shunk's jumps. The first jump was his clearance at 2.21 m; the second one was his second miss at 2.27 m (jump 95). The middle photo of the first sequence (the 2.21 m clearance) shows what the takeoff foot looks like immediately after the entire shoe sole establishes full contact with the ground, before hardly any pronation has occurred. A comparison of this photo with the left photo of the same jump and with the middle and left photos of the second miss at 2.27 m (all three of which corresponded to slightly later times within the takeoff

2.21 m clearance

2.27 m second miss
(jump 95)

phase) shows that, in the latter three photos, the outside edge of the shoe was lifted off from the ground. This indicated that there was pronation. Given the very large value of the e_3 angle in jump 95 and the existence of pronation in Shunk's jumps (even though we can't judge very well how severe that pronation was), our advice to Shunk is to play it safe, and plant the takeoff foot more in line with the final direction of the run-up.

A minor problem in Shunk's technique was the somewhat weak action of his lead leg. It would be good to lift the knee of the right leg higher by the end of the takeoff. This should help Shunk to generate a slightly larger amount of lift.

Shunk should not make any changes in his leans at the start nor at the end of the takeoff phase, nor in his actions over the bar, because these aspects of his technique are already near-perfect. It is true that Shunk did not rotate forward enough during the takeoff phase, and that this limited his forward component of somersaulting angular momentum, and consequently also his total amount of somersaulting angular momentum. However, this was not a problem for him. The amount of somersaulting angular momentum that he generated, together with his very good actions in the air, produced an extremely effective bar clearance: He would have been able to clear a bar set 1 cm higher than the peak height reached by his c.m. This is the most effective bar clearance that we have ever measured in an American high jumper. That is why we advise Shunk

not to make any changes in his leans at the start nor at the end of the takeoff phase, nor in his actions over the bar

We do advise Shunk to take off a little bit farther from the bar than he did in jump 95. This is necessary in order to center his body better over the bar, and thus to reap the full benefits of his excellent bar clearance.

So our main advice to Shunk is to pass more smoothly over the right leg in the penultimate step of the run-up, losing little or no horizontal speed, and to plant the takeoff foot more in line with the final direction of the run-up. He also needs to take care not to take off too close to the bar.

SHUNK #95 062407 2.27 M MISS

RUN-UP

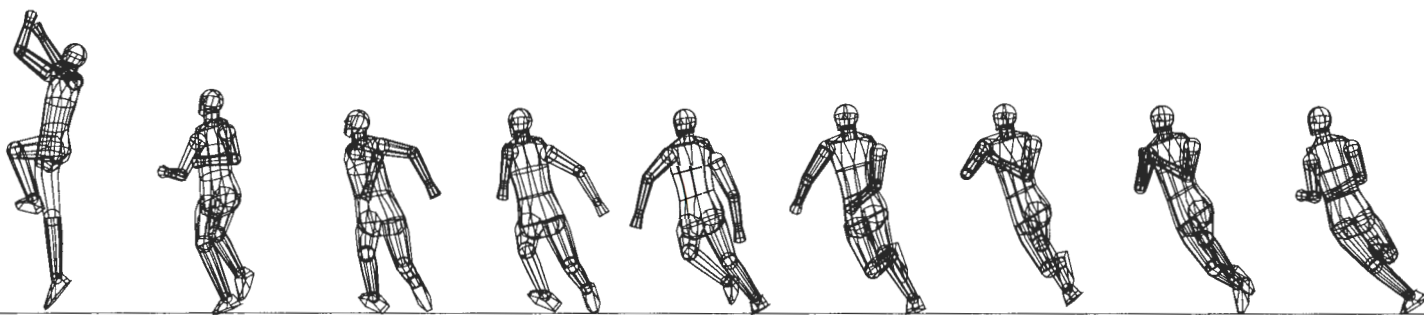
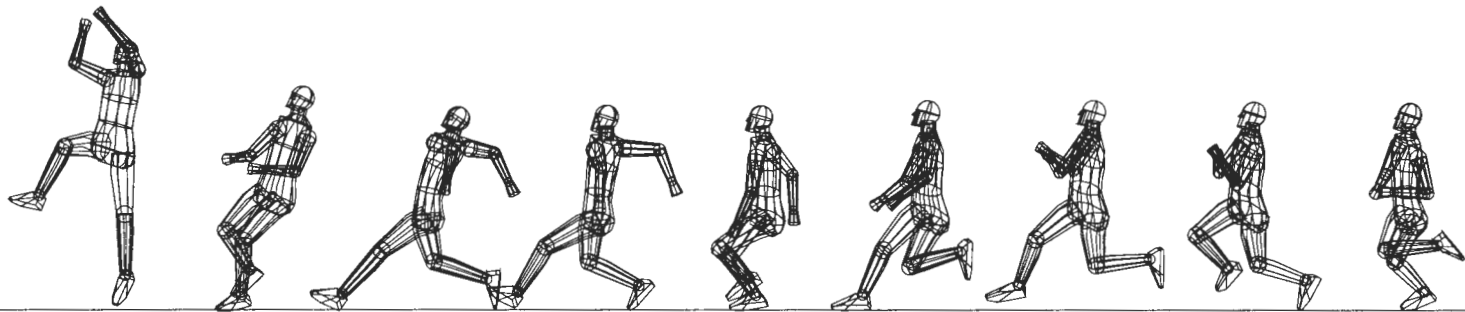

10.20

10.10

10.00

9.94

9.88

9.82

9.76

9.70

9.64

SHUNK #95 062407 2.27 M MISS

TAKEOFF PHASE

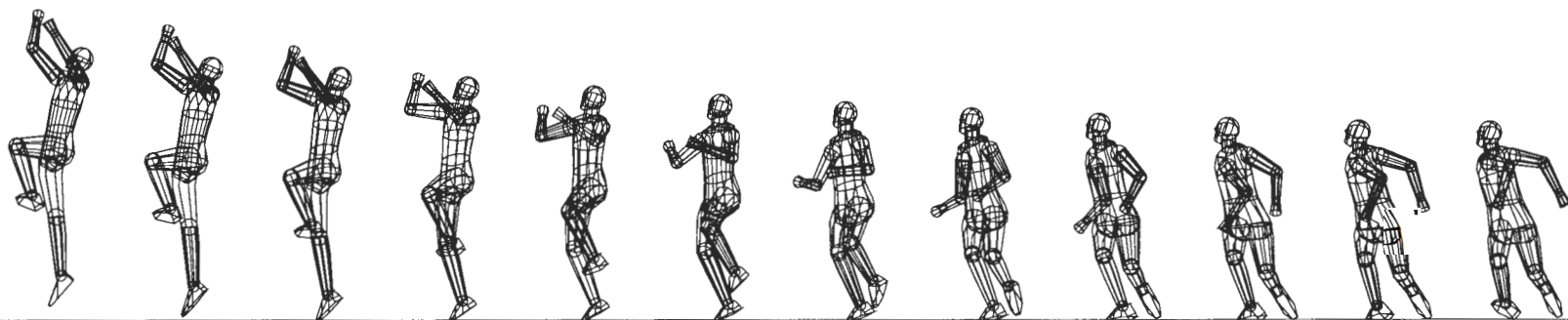
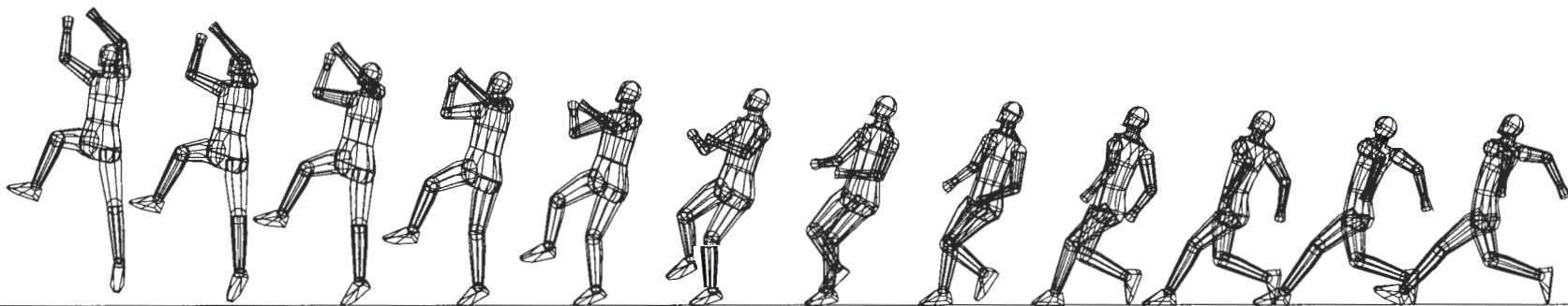

10.22

10.20

10.18

10.16

10.14

10.12

10.10

10.08

10.06

10.04

10.02

10.00

SHUNK #95 062407 2.27 M MISS

BAR CLEARANCE

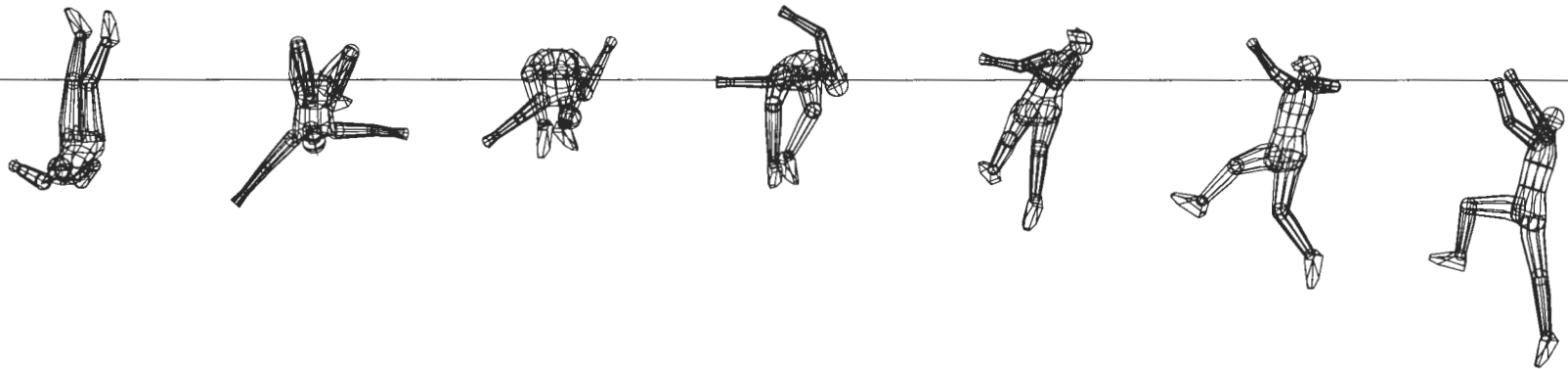
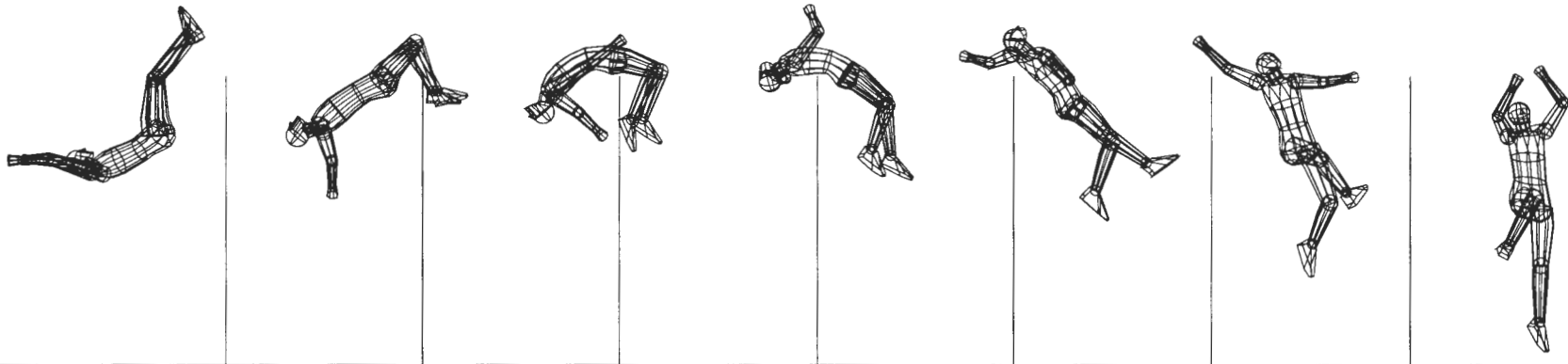

10.94

10.82

10.70

10.58

10.46

10.34

10.22

C.M. HEIGHT VS TIME

|
9.40

|
9.60

|
9.80

|
10.00

SHUNK #95 062407 2.27 M MISS

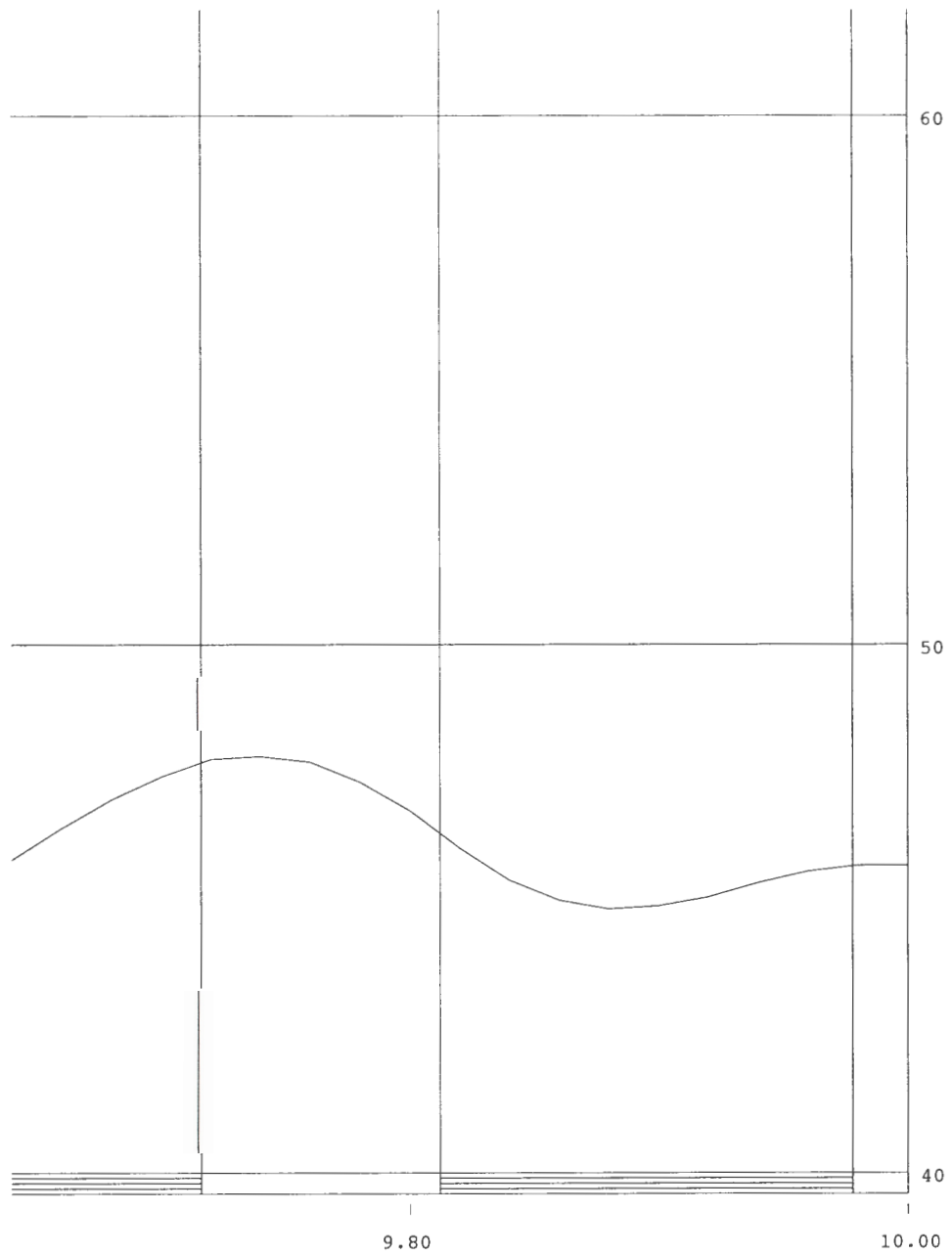

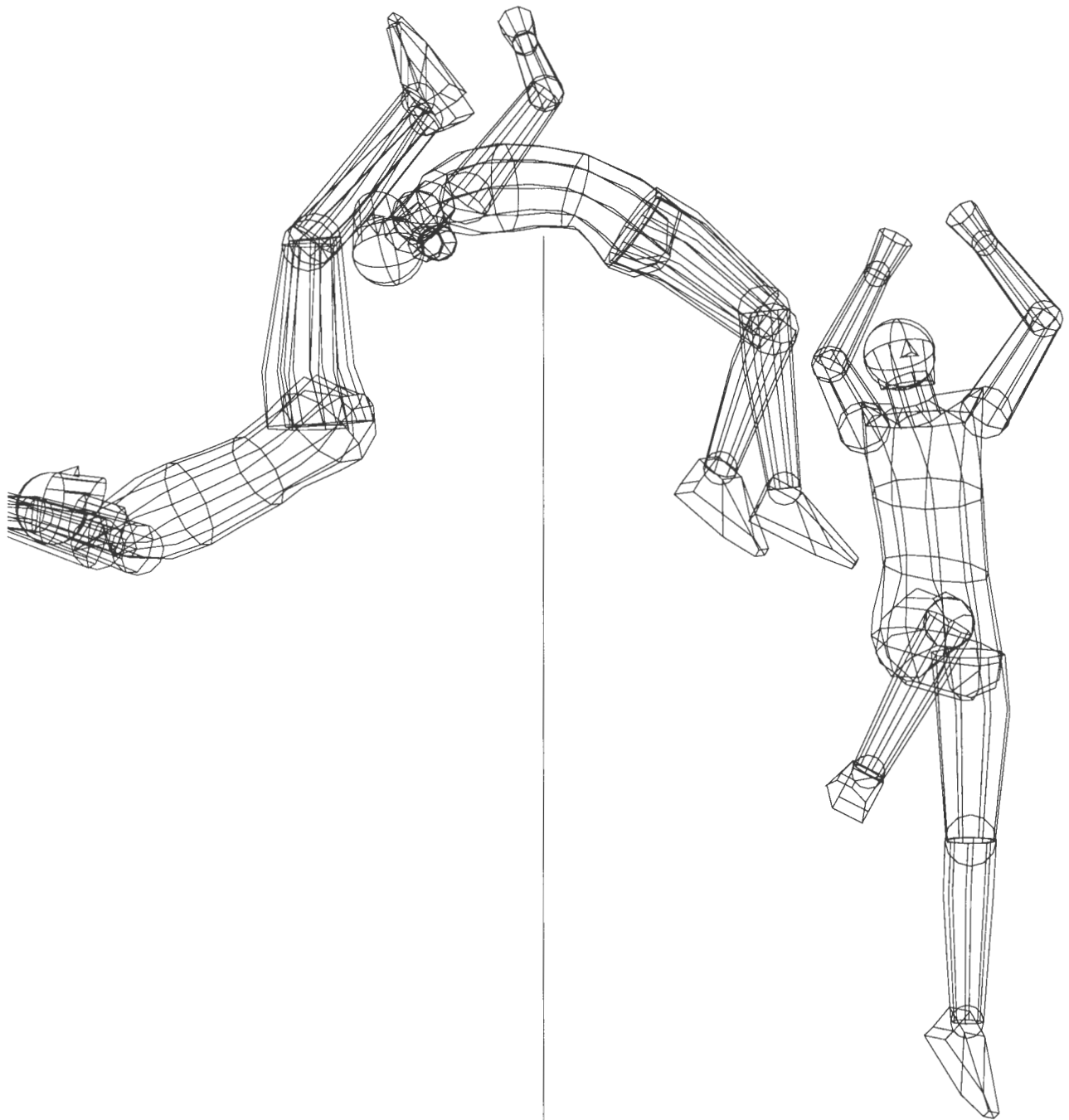

SHUNK #95 062407 2.27 M MISS

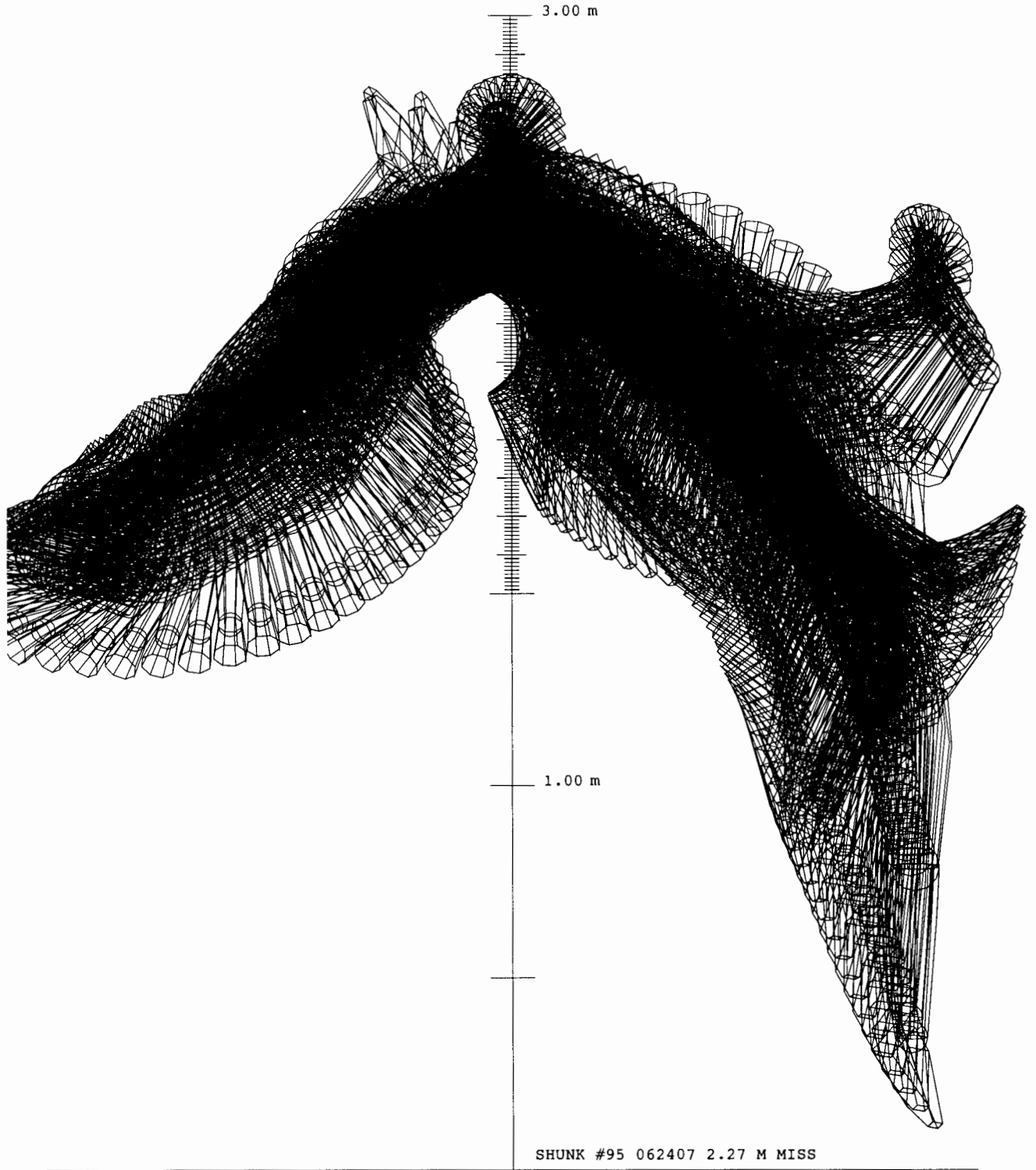

Jesse WILLIAMS

Jump 82 was Williams' last successful clearance at the 2007 USATF Championships (2.24 m).

Based on Williams' vertical velocity at takeoff in jump 82 ($v_{ZTO} = 4.50$ m/s), a technique of average quality would have included a c.m. height at the end of the run-up equal to about 46.5% of his own standing height, and a final run-up speed of about 7.6 m/s. Williams' actual speed at the end of the run-up ($v_{HI} = 7.7$ m/s) was slightly faster than what might have been expected for a technique of average quality, but he was also higher ($h_{TD} = 48\%$). The overall combination of run-up speed and c.m. height that Williams used in jump 82 was not very bad, but also not particularly good.

At the end of the run-up, Williams planted the takeoff foot too parallel to the bar. Because of this, the angle between the longitudinal axis of the takeoff foot and the horizontal force received by the foot was extremely large ($e_3 = 54^\circ$). This produced a very large risk of foot pronation, and injury to the ankle and foot. (See the section on "Orientation of the takeoff foot, and potential for ankle and foot injuries" in the main text of the report.) The danger was confirmed through direct viewing of the videos, which showed a large amount of pronation in all of Williams' jumps. (See the images on this page.)

Williams did not prepare his arms for a double-arm takeoff. (See the side-view and back-view sequences of the run-up between $t = 9.64$ s and $t = 10.00$ s.) Still, he managed to have both arms in low positions at the start of the takeoff phase ($t = 10.00$ s), and this raised the possibility that he might still be able to execute reasonably strong arm actions during the takeoff phase. Indeed, Williams lifted his left arm to a high position by the end of the takeoff phase, so its action was strong ($AAN = 9.0$ mm/m). (See the detailed sequence of the takeoff phase between $t = 10.00$ s and $t = 10.16$ s; see also Figure 9 in the main text of the report.) He also lifted his right elbow to a high position by the end of the takeoff phase, but in addition he executed an internal rotation of the right upper arm that put the right forearm in a horizontal position at the end of the takeoff, which put the right hand in a lower position than the right shoulder. (See the sequence of the takeoff phase at $t = 10.16$ s.) This made the action of Williams' right arm be very weak ($AAF = 5.1$ mm/m). Keep in mind that the arm farthest from the bar (the right arm in Williams' case) is the one that normally makes a stronger action in most high jumpers. Because of the weak action of his right arm, Williams' total arm

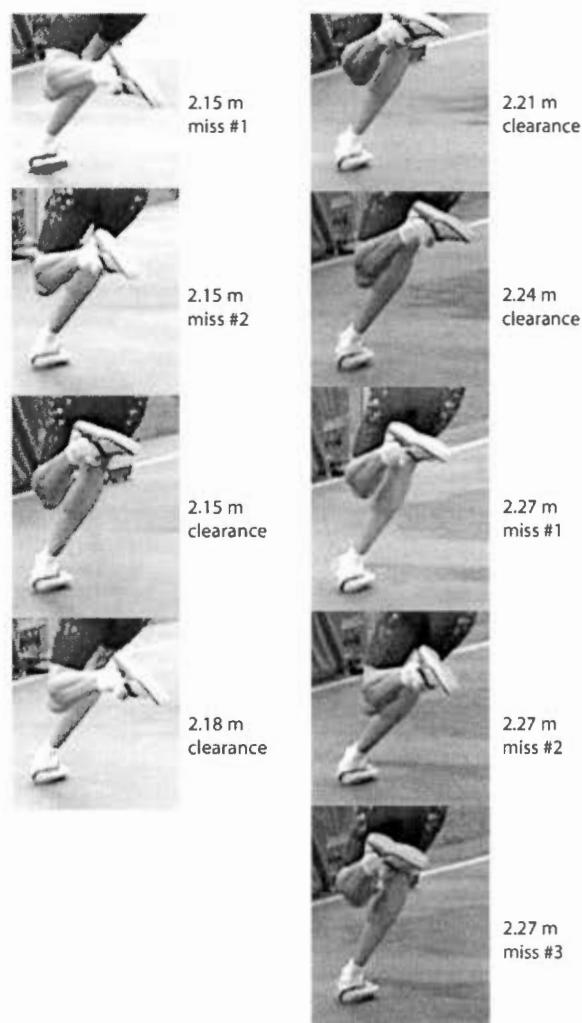

action was weak ($AAT = 14.2$ mm/m). Williams did not lift his left knee high enough at the end of the takeoff phase. Therefore, the action of his lead leg was weak ($LLA = 12.4$ mm/m). His overall combination of arm and lead leg actions was also weak ($FLA = 26.5$ mm/m).

Williams had a moderate amount of backward lean at the start of the takeoff phase in jump 82 ($BFTD = 76^\circ$). Then he rotated forward during the takeoff phase, and at the end of the takeoff he was essentially vertical ($BFTO = 89^\circ$). This was all very good, and it allowed him to generate a large amount of forward somersaulting angular momentum ($H_F = 80$).

Williams' trunk had a good lean toward the right at the start of the takeoff phase ($LRTD = 76^\circ$). Then he rotated toward the left, and at the end of the takeoff he was 1° short of the vertical in a view from the back ($LRTO = 89^\circ$). In the view from the back,

it's normal to go a few degrees past the vertical at the end of the takeoff. We consider it acceptable (indeed, desirable) to tilt up to 10° past the vertical at the end of the takeoff phase (in the view from the back) because we believe that this may be the best compromise between the generation of lift and the generation of rotation (angular momentum). Therefore, Williams' lack of lean toward the left at the end of the takeoff was very "conservative", and the amount of lateral somersaulting angular momentum that he was able to generate was small ($H_L = 75$).

Williams' large amount of forward somersaulting angular momentum and small amount of lateral somersaulting angular momentum combined into a somewhat small total amount of somersaulting angular momentum ($H_S = 110$).

Williams' c.m. reached a maximum height $h_{PK} = 2.32$ m in jump 82. The "saturation graph" shows that in this jump he could have cleared cleanly a bar set at about $h_{CLS} = 2.25$ m, and at $h_{CLA} = 2.27$ m if he had taken off about 5 cm closer to the plane of the bar and the standards. In relation to the peak height of the c.m. (2.32 m), the 2.27 m clean clearance height indicated a reasonably effective bar clearance.

Although we classify Williams' bar clearance as "reasonably effective", this is not the same as saying that he should be satisfied with it. Computer animations of jump 82 showed that Williams started his un-arching prematurely, and we wondered if a change in the timing of Williams' un-arching might help him to produce a more effective bar clearance.

To investigate this question further, we made tests using computer simulation of the bar clearance. We made two computer simulations. In the first one of these computer-generated jumps ("simulation #1") we kept the position of the body at takeoff, the angular momentum, the path of the c.m. and the motions of the body segments relative to each other after takeoff the same as in the original jump 82. Graphic sequences of this simulation (view from overhead; view perpendicular to the plane of the bar and the standards; view in line with the bar) are shown in one of the graphics pages that follow these comments. The result was a simulated jump very similar to the original jump. This is a standard practice in computer simulation, to check that the simulation program is functioning properly. The graphic sequences of this unaltered simulated jump are shown here to provide a basis for comparison with simulation #2. (The sequences of the simulated jump also happen to show more images of the

airborne motions than the main sequence of jump 82's bar clearance. Therefore, the reader can use them to check that Williams indeed started to un-arch too soon. See the view along the bar of simulation #1 between $t = 10.64$ s and $t = 10.76$ s. The sequence shows that Williams started to un-arch before his hips had crossed over to the other side of the bar.)

In simulation #2 we kept the position at takeoff, the angular momentum and the path of the c.m. the same as in the original jump. In the air, we had Williams execute, on the way up to the bar (up to $t = 10.64$ s), the same actions as in the original jump 82. But from that point onward we had him change his actions. (See the view along the bar in the sequence of simulation #2.) We had him keep his knees lowered for a little bit longer than in the original jump (between $t = 10.64$ s and $t = 10.76$ s); then we had him lift his knees very strongly ($t = 10.76$ - 10.88 s) to avoid dragging the bar down with his calves.

The "saturation graph" of simulation #2 showed that, with these alterations in his actions over the bar, Williams would have been able to clear cleanly a bar set at a height of 2.30 m. A height of 2.30 m is 0.03 m higher than the 2.27 m height (h_{CLA}) that Williams could have cleared cleanly in the original jump, and only 0.02 m lower than the peak height reached by the c.m. (2.32 m). This would qualify as a very effective bar clearance.

Recommendations

The main problem in Williams' technique was the orientation of his takeoff foot. He should plant the takeoff foot on the ground with the longitudinal axis of the foot more in line with the final direction of the run-up: The foot should be planted on the ground in a more counterclockwise orientation, with the toe pointing at least 35° more toward the landing pit than in jump 82. This technique change will help to prevent ankle pronation, and injury to the ankle and foot. This is a health-related issue rather than a performance-related issue, but nevertheless it is the most important problem in Williams' technique.

From a performance standpoint, the most important problem in Williams' technique was his combination of speed and c.m. height at the end of the run-up. He needs to be faster and/or lower than in jump 82. The optimum combination for any jumper is faster and/or lower than the expected average ("ordinary") combination. In terms of Figure 3, all solutions to this problem involve moving Williams' point to the diagonal line recommended for $v_{ZTO} = 4.50$ m/s. One possible option would be to

combine the height that Williams had at the end of the run-up in jump 82 ($h_{TD} = 48\%$) with a much faster speed ($v_{HI} = 8.2$ m/s). (See the horizontal arrow in the graph shown on this page.) This larger amount of final run-up speed should allow Williams to generate more lift during the takeoff phase, and thus to produce a larger height for his c.m. at the peak of the jump. (See Appendix 2 for exercises that will help to produce fast and low conditions at the end of the run-up.) An alternative option would be to put the c.m. in a lower position at the end of the run-up, equivalent for instance to about 46.5% of Williams' own standing height. This would be a final run-up height similar to those used by Littleton, Nieto and Shunk in 2007. With such a position at the end of the run-up, a final horizontal speed of about 8.0 m/s would be sufficient to qualify as optimal. (See the arrow pointing downward and toward the right in the graph.)

(Standard caution when increasing the run-up speed and/or lowering the c.m. height at the end of the run-up: The use of a faster and/or lower run-up will put a greater stress on the takeoff leg, and thus it may increase the risk of injury if the leg is not strong enough. Therefore, it is always important to use caution in the adoption of a faster and/or lower run-up. If the desired change is very large, it would be advisable to make it gradually, over a period of time. In all cases, it may be wise to further strengthen the takeoff leg, so that it can withstand the increased force of the impact produced when the takeoff leg is planted.)

The second most important performance-related problem in Williams' technique was probably the mediocre effectiveness of his bar clearance. This can be improved in various ways: (a) It would be good if Williams rotated further toward the left during the takeoff phase, to a position about 10° beyond the vertical (in the view from the back) at the end of the takeoff phase. This would allow him to generate a larger amount of lateral somersaulting angular momentum, and therefore also a larger total amount of somersaulting angular momentum. The result will be an improved rotation over the bar, and probably better effectiveness in the bar clearance. (b) Williams also has to be careful not to take off too far from the plane of the bar and the standards (a problem that he had in jump 82). (c) But most importantly for the effectiveness of his bar clearance, Williams needs to delay briefly the start of his un-arching until after his hips have crossed over to the other side of the bar. Then he needs to un-arch very strongly and suddenly, as shown in simulation #2. It is possible that the implementation of "c" might

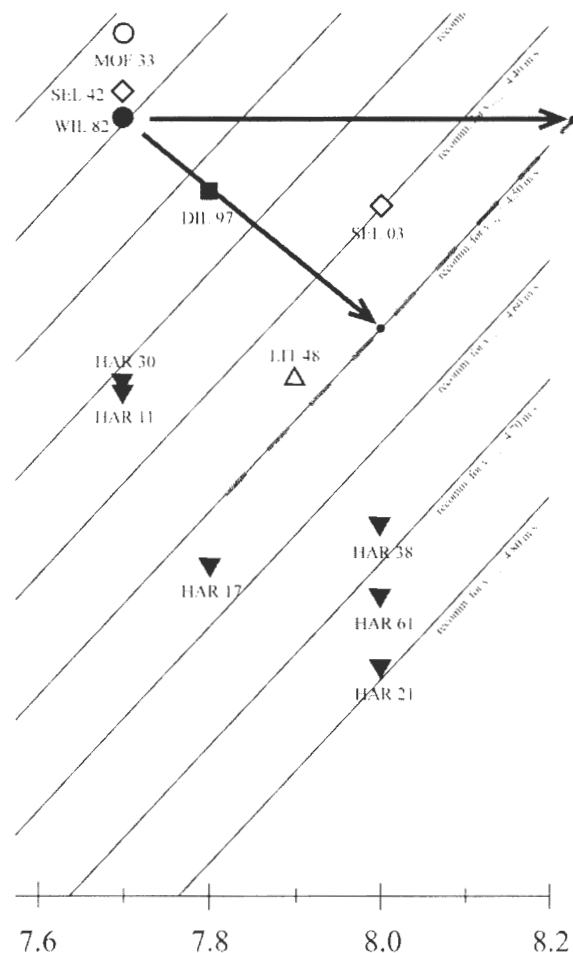

require some prior strengthening of Williams' hip flexor muscles (the muscles that cross over the front of the hip) and also of his abdominal muscles.

The third most important performance-related problem in Williams' technique was probably the weakness of his free-limb actions during the takeoff phase. Williams should swing his right arm and the knee of his left leg harder forward and up, to higher positions by the end of the takeoff phase. This will help him to obtain more lift from the ground.

J. WILLIAMS #82 062407 2.24 M CLEARANCE

RUN-UP

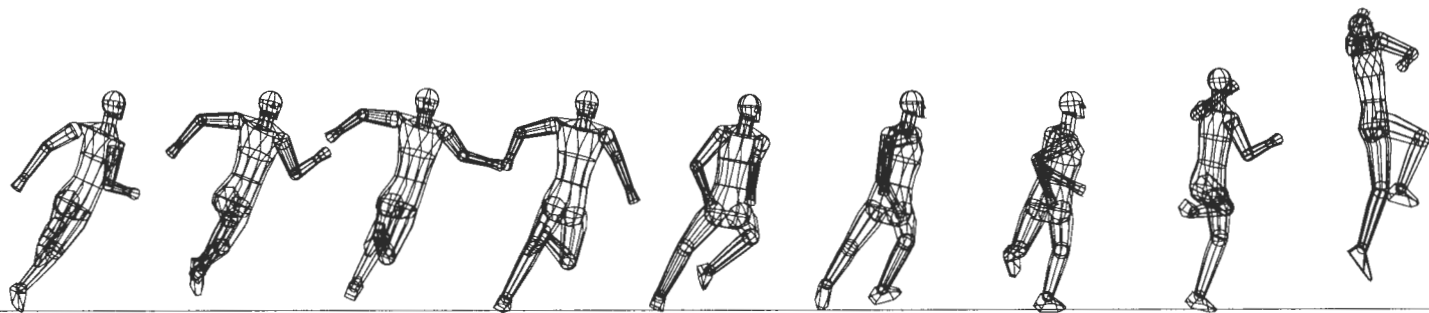
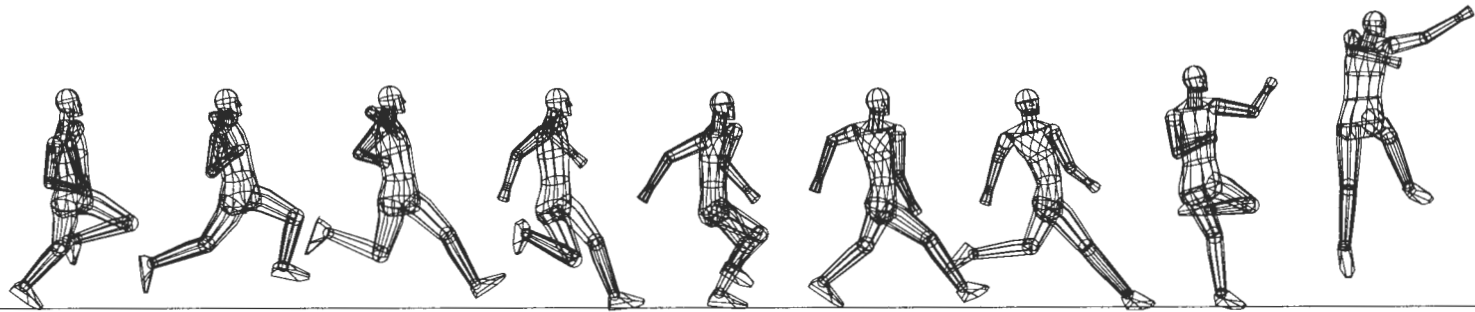

9.64

9.70

9.76

9.82

9.88

9.94

10.00

10.10

10.20

J. WILLIAMS #82 062407 2.24 M CLEARANCE

TAKEOFF PHASE

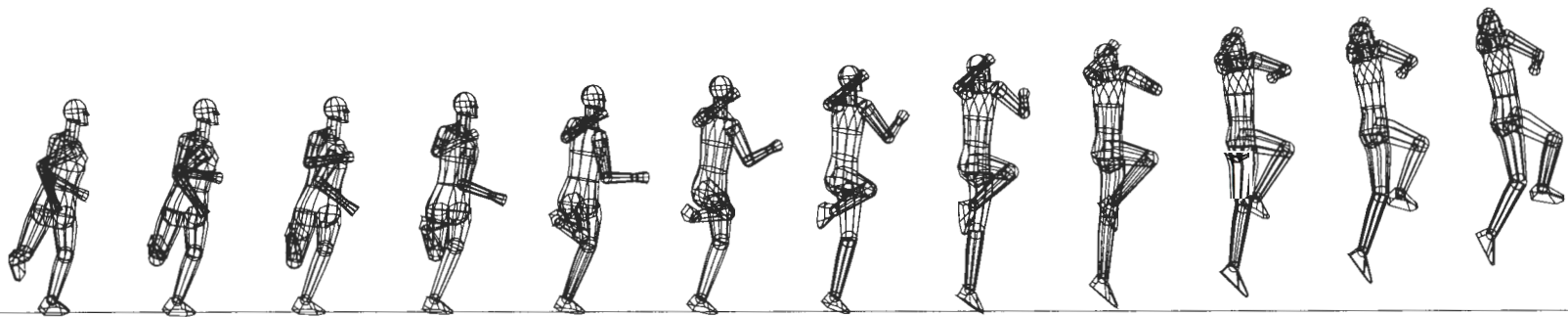
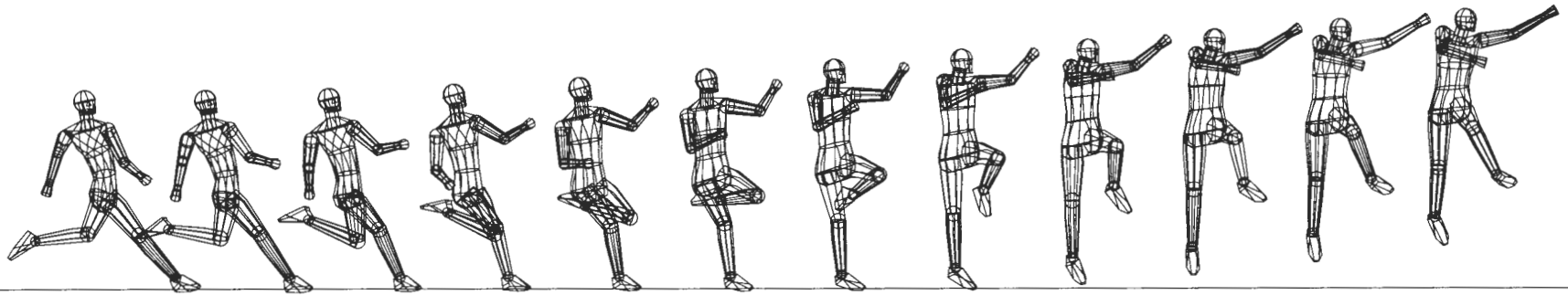

10.00

10.02

10.04

10.06

10.08

10.10

10.12

10.14

10.16

10.18

10.20

10.22

J. WILLIAMS #82 062407 2.24 M CLEARANCE

BAR CLEARANCE

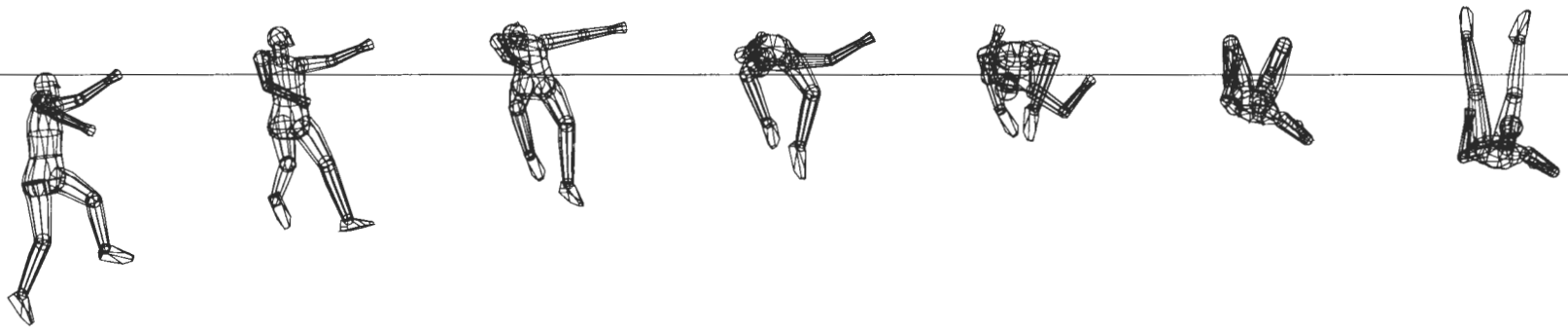
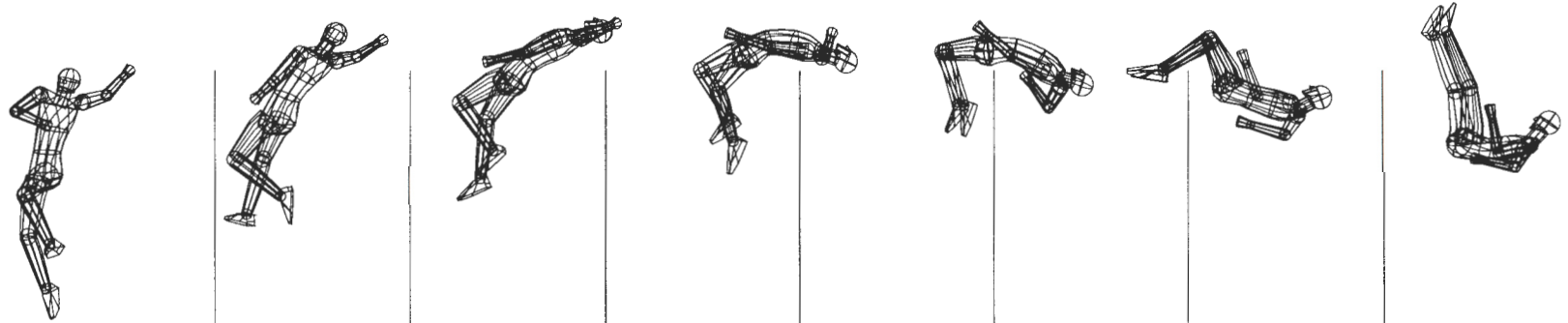

10.22

10.34

10.46

10.58

10.70

10.82

10.94

C.M. HEIGHT VS TIME

9.40

9.60

9.80

10.00

J. WILLIAMS #82 062407 2.24 M CLEARANCE

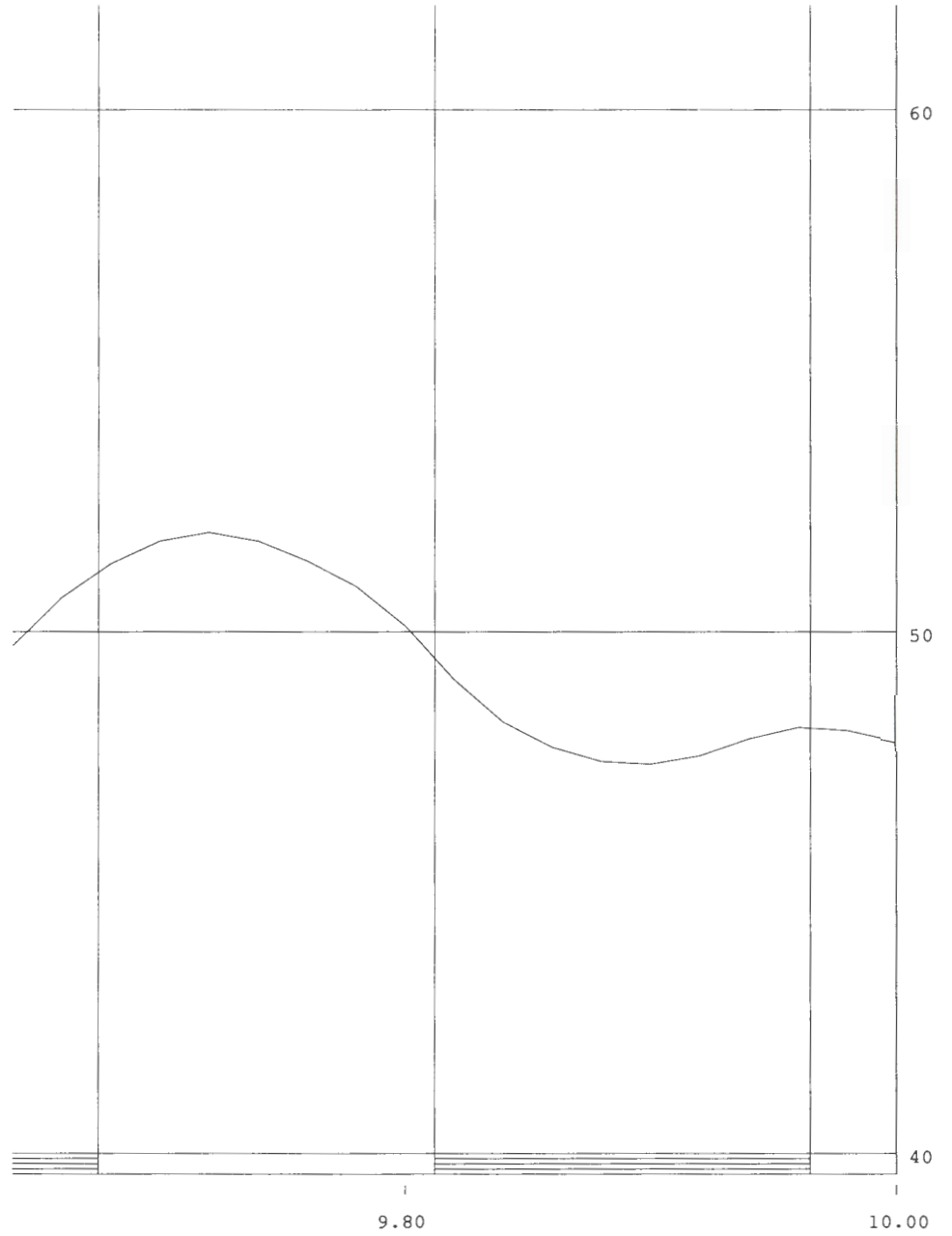

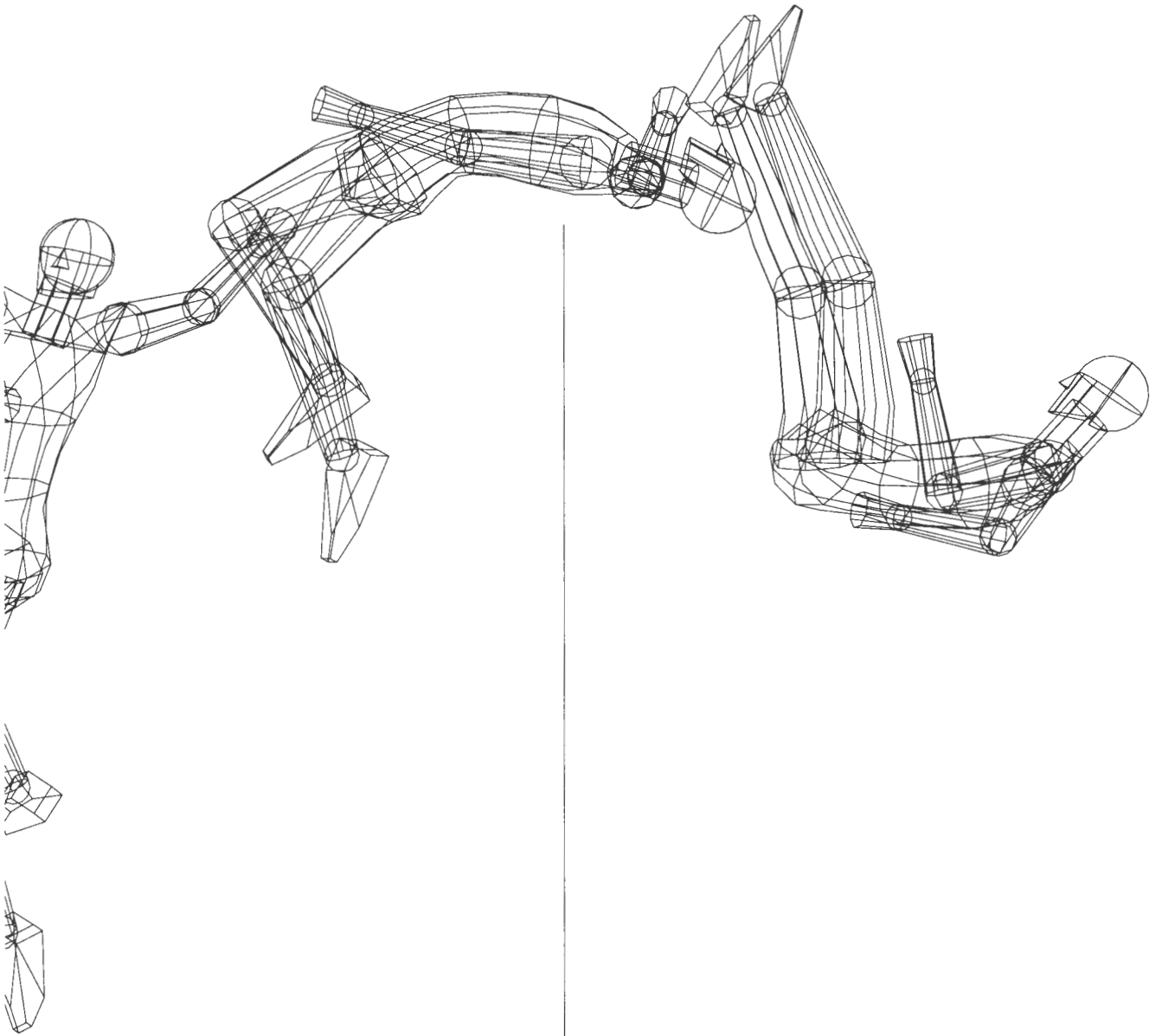

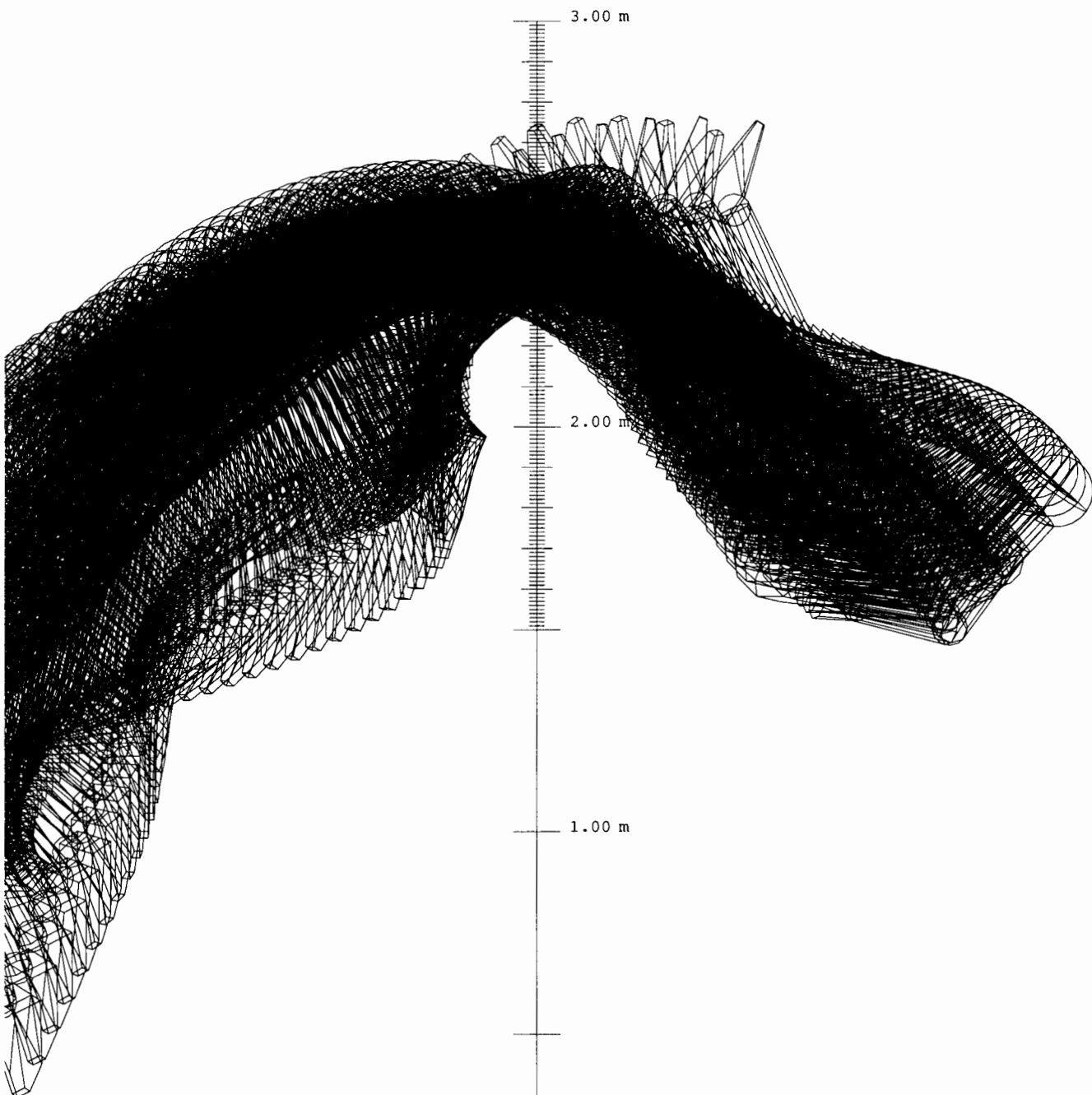

J. WILLIAMS #82 062407 2.24 M CLEARANCE

SIMULATION #1

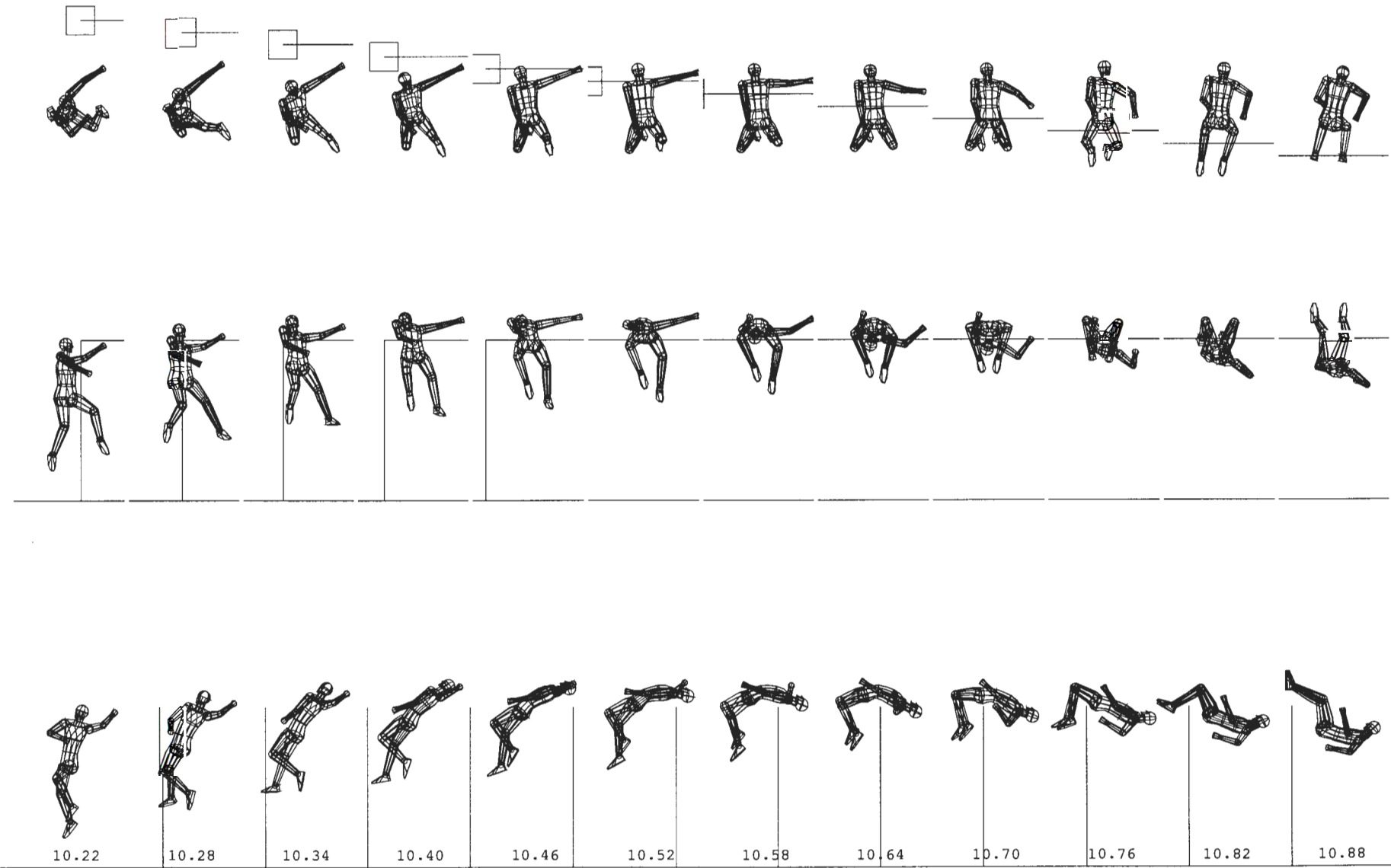

SIMULATION #2

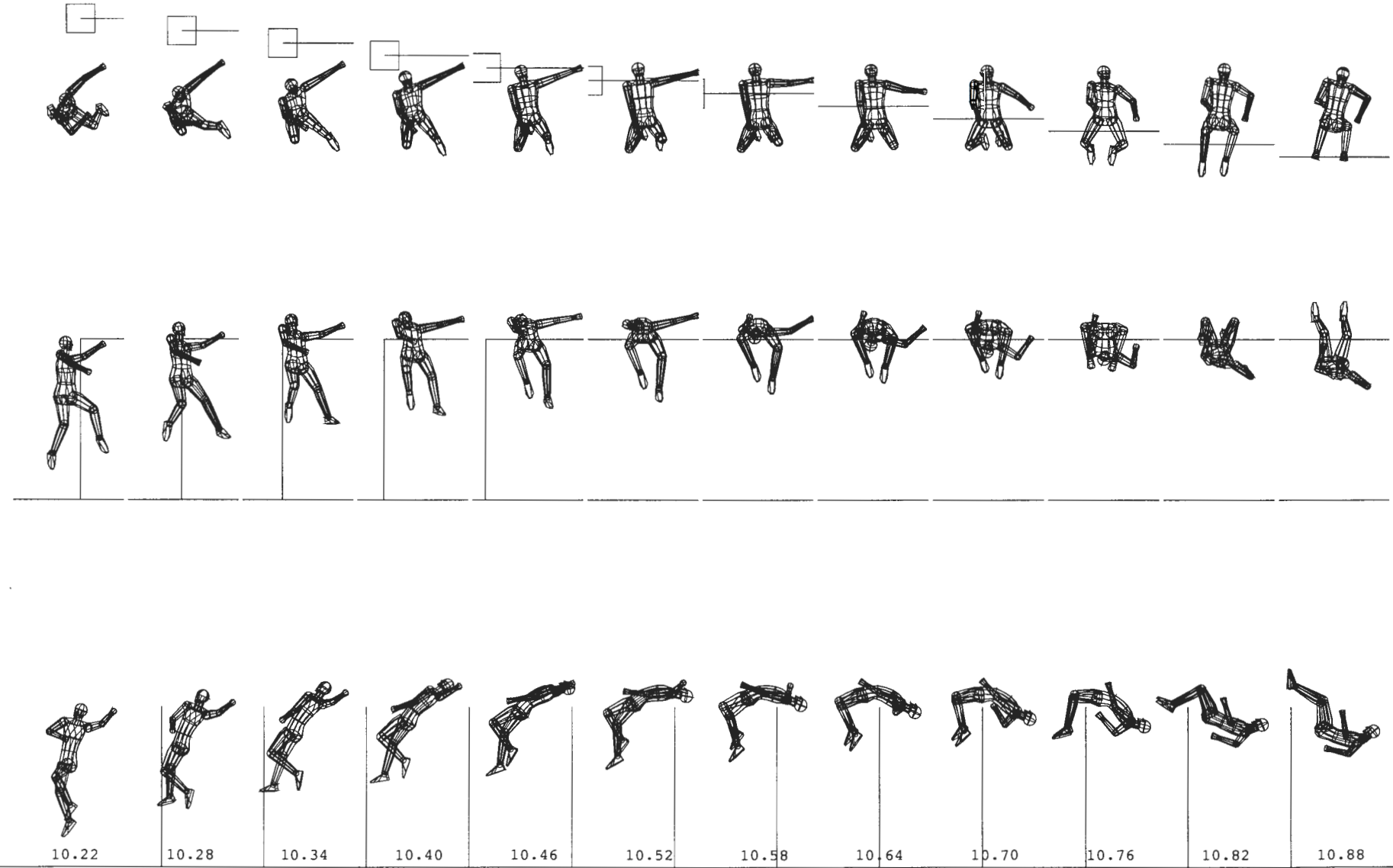

COMPUTER-SIMULATED JUMP

SIMULATION #2

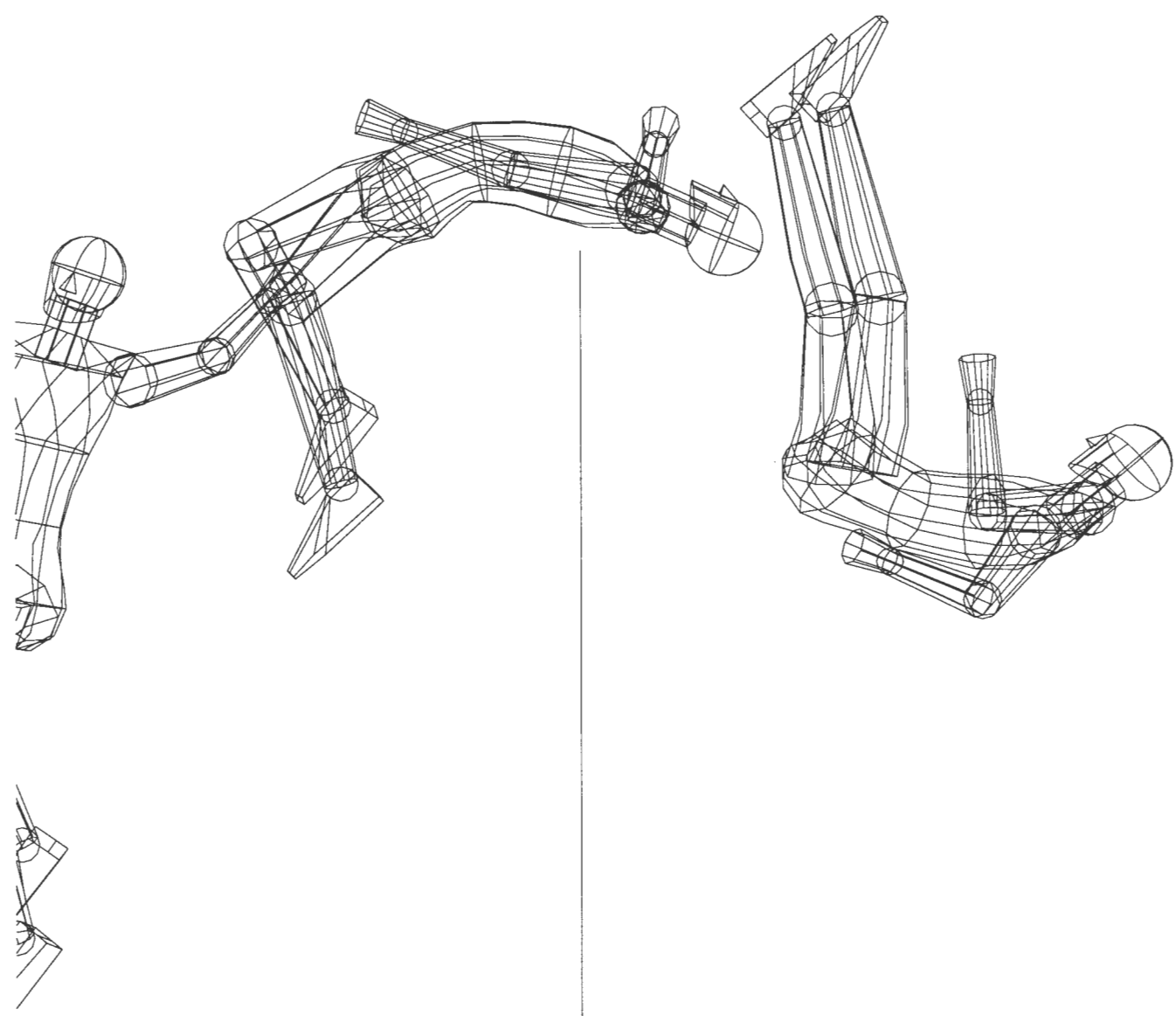

COMPUTER-SIMULATED JUMP

SIMULATION #2

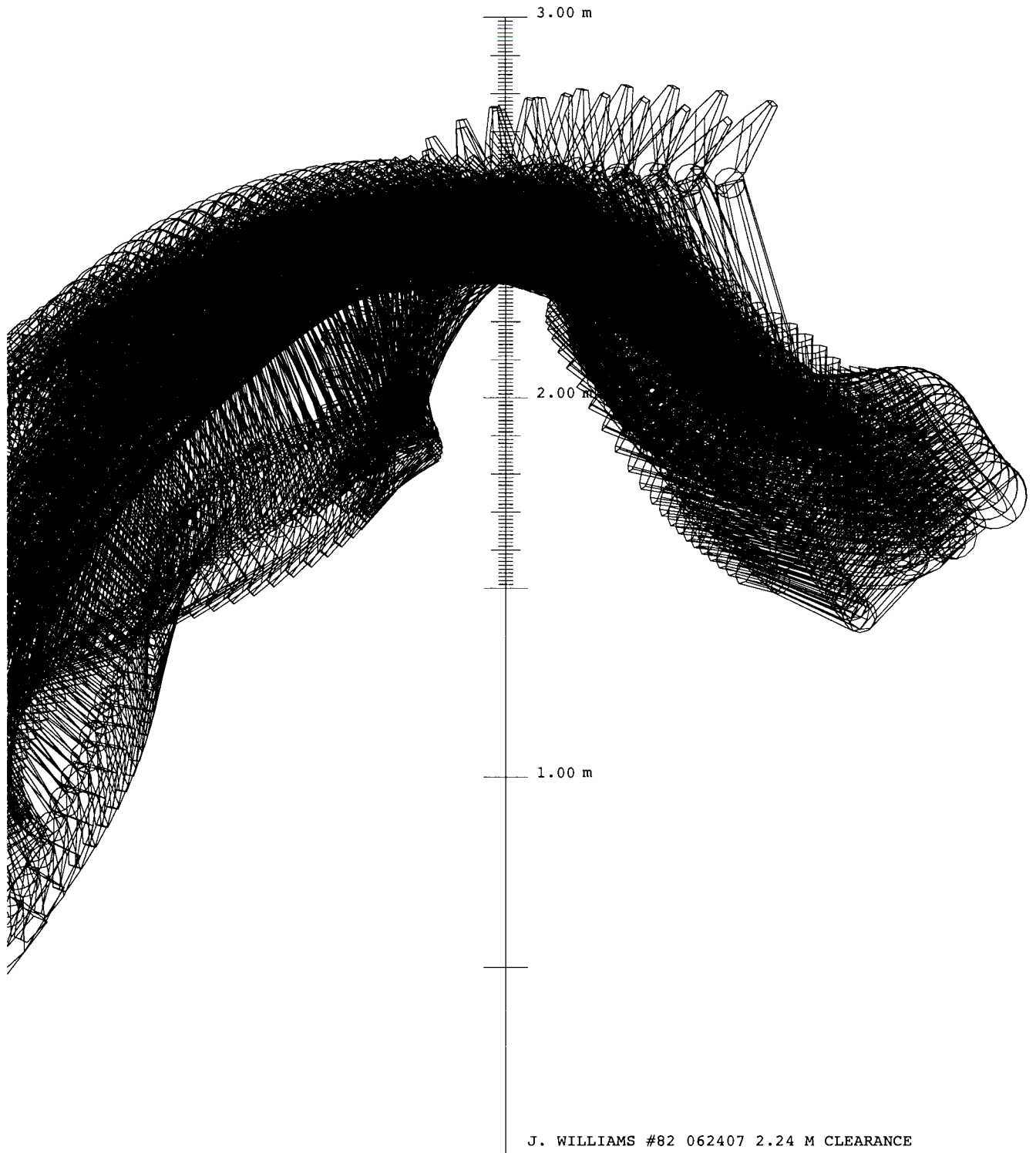

REFERENCES

1. Dapena, J. Mechanics of translation in the Fosbury-flop. *Med. Sci. Sports Exerc.* 12:37-44, 1980a.
2. Dapena, J. Mechanics of rotation in the Fosbury-flop. *Med. Sci. Sports Exerc.* 12:45-53, 1980b.
3. Dapena, J. Simulation of modified human airborne movements. *J. Biomech.* 14:81-89, 1981.
4. Dapena, J. Basic and applied research in the biomechanics of high jumping. *Current Research in Sports Biomechanics*. Eds. B. Van Gheluwe and J. Atha. Karger, Basel, 19-33, 1987a.
5. Dapena, J. Biomechanical analysis of high jump, #7 (Men). *Report for Scientific Services Project (USOC/TAC)*. U.S. Olympic Training Center, Colorado Springs, 215 pp, 1987b.
6. Dapena, J. Biomechanical analysis of high jump, #8 (Women). *Report for Scientific Services Project (USOC/TAC)*. U.S. Olympic Training Center, Colorado Springs, 221 pp, 1987c.
7. Dapena, J. How to design the shape of a high jump run-up. *Track Coach* 131:4179-4181, 1995a.
8. Dapena, J. The rotation over the bar in the Fosbury-flop high jump. *Track Coach* 132:4201-4210, 1995b.
9. Dapena, J., M. Ae and A. Iiboshi. A closer look at the shape of the high jump run-up. *Track Coach* 138:4406-4411, 1997a.
10. Dapena, J., W.J. Anderst and M.K. LeBlanc. High jump, #14 (Men). *Report for Scientific Services Project (USATF)*. USA Track & Field, Indianapolis, 113 pp, 1995b.
11. Dapena, J., R.M. Angulo-Kinzler, J.M. Caubet, C. Turró, X. Balius, S.B. Kinzler, J. Escoda and J.A. Prat. Track and field: high jump (Women). *Report for 1992 Summer Olympic Games Biomechanics Projects (IOC: Medical Commission / Biomechanics Subcommission)*. International Olympic Committee, Lausanne, Switzerland, 261 pp, 1993a.
12. Dapena, J., R.M. Angulo-Kinzler, C. Turró, J.M. Caubet, X. Balius, S.B. Kinzler, J. Escoda and J.A. Prat. Track and field: high jump (Men). *Report for 1992 Summer Olympic Games Biomechanics Projects (IOC: Medical Commission / Biomechanics Subcommission)*. International Olympic Committee, Lausanne, Switzerland, 212 pp, 1993b.
13. Dapena, J. and R. Bahamonde. Biomechanical analysis of high jump, #9 (Men). *Report for Scientific Services Project (USOC/TAC)*. The Athletics Congress, Indianapolis, 190 pp, 1991.
14. Dapena, J., R. Bahamonde, M. Feltner, I. Oren and O. Nicklass. Biomechanical analysis of high jump, #3 (Men). *Report for Elite Athlete Project (USOC/TAC)*. U.S. Olympic Training Center, Colorado Springs, 86 pp, 1983b.
15. Dapena, J. and C.S. Chung. Vertical and radial motions of the body during the take-off phase of high jumping. *Med. Sci. Sports Exerc.* 20:290-302, 1988.
16. Dapena, J. and M. Feltner. Biomechanical analysis of high jump, #6 (High School Males). *Report for Scientific Services Project (USOC/TAC)*. U.S. Olympic Training Center, Colorado Springs, 128 pp, 1986c.
17. Dapena, J., M. Feltner and R. Bahamonde. Biomechanical analysis of high jump, #5 (Men). *Report for Scientific Services Project (USOC/TAC)*. U.S. Olympic Training Center, Colorado Springs, 200 pp, 1986b.
18. Dapena, J., M. Feltner, R. Bahamonde and C.S. Chung. Biomechanical analysis of high jump, #4 (Women). *Report for Scientific Services Project (USOC/TAC)*. U.S. Olympic Training Center, Colorado Springs, 273 pp, 1986a.
19. Dapena, J., M. Feltner, R. Bahamonde, O. Nicklass and I. Oren. Biomechanical analysis of high jump, #2 (Women). *Report for Elite Athlete Project (USOC/TAC)*. U.S. Olympic Training Center, Colorado Springs, 119 pp, 1983a.
20. Dapena, J. and B.J. Gordon. High jump, #17 (Women). *Report for Scientific Services Project (USATF)*. USA Track & Field, Indianapolis, 139 pp, 1998a.
21. Dapena, J. and B.J. Gordon. High jump, #19 (Women). *Report for Scientific Services Project (USATF)*. USA Track & Field, Indianapolis, 115 pp, 1999.
22. Dapena, J. and B.J. Gordon. High jump, #27 (Women). *Report for Scientific Services Project (USATF)*. USA Track & Field, Indianapolis, 112 pp, 2004a.
23. Dapena, J., B.J. Gordon and T.K. Ficklin. High jump, #31 (Women). *Report for Scientific Services Project (USATF)*. USA Track & Field, Indianapolis, 116 pp, 2007.
24. Dapena, J., B.J. Gordon, L. Hoffman and M.K. LeBlanc. High jump, #15 (Women). *Report for Scientific Services Project (USATF)*. USA Track & Field, Indianapolis, 94 pp, 1997b.
25. Dapena, J., B.J. Gordon and B.W. Meyer. High jump, #25 (Women). *Report for Scientific Services Project (USATF)*. USA Track & Field, Indianapolis, 117 pp, 2003a.
26. Dapena, J., B.J. Gordon and B.W. Meyer. High jump, #29 (Women). *Report for Scientific Services Project (USATF)*. USA Track & Field, Indianapolis, 103 pp, 2006a.
27. Dapena, J., B.J. Gordon and A.P. Willmott. High jump, #21 (Women). *Report for Scientific Services Project (USATF)*. USA Track & Field, Indianapolis, 99 pp, 2001a.
28. Dapena, J., B.J. Gordon and A.P. Willmott. High jump, #24 (Women). *Report for Scientific Services Project (USATF)*. USA Track & Field, Indianapolis, 91 pp, 2002b.
29. Dapena, J., E. Harman, P. Stewart, G. Lunt and R. Hintermeister. Biomechanical analysis of high jump, #1 (Men and Women). *Report for Elite Athlete Project (USOC/TAC)*. U.S. Olympic Training Center, Colorado Springs, 152 pp, 1982.
30. Dapena, J., L. Hoffman, B.J. Gordon and M.K. LeBlanc. High jump, #16 (Men). *Report for Scientific Services Project (USATF)*. USA Track & Field, Indianapolis, 112 pp, 1997c.
31. Dapena, J. and M.K. LeBlanc. High jump, #13 (Women). *Report for Scientific Services Project*

- (USATF). USA Track & Field, Indianapolis, 157 pp, 1995a.
32. Dapena, J., M.K. LeBlanc, R. E. Vaughn, G. Lewis Johnston and W.J. Anderst. High jump, #11 (Men). *Report for Scientific Services Project (USATF/USOC)*. USA Track & Field, Indianapolis, 178 pp, 1994a.
 33. Dapena, J., M.K. LeBlanc, R.E. Vaughn, G. Lewis Johnston and W.J. Anderst. High jump, #12 (Women). *Report for Scientific Services Project (USATF/USOC)*. USA Track & Field, Indianapolis, 125 pp, 1994b.
 34. Dapena, J., C. McDonald and J. Cappaert. A regression analysis of high jumping technique. *Int. J. Sport Biomech.* 6:246-261, 1990.
 35. Dapena, J., R. E. Vaughn and G. Lewis Johnston. High jump, #10 (Men). *Report for Scientific Services Project (USATF)*. USA Track & Field, Indianapolis, 165 pp, 1993c.
 36. Dapena, J. and A.P. Willmott. High jump, #22 (Men). *Report for Scientific Services Project (USATF)*. USA Track & Field, Indianapolis, 128 pp, 2001b.
 37. Dapena, J. and A.P. Willmott. High jump, #23 (Men). *Report for Scientific Services Project (USATF)*. USA Track & Field, Indianapolis, 85 pp, 2002a.
 38. Dapena, J., A.P. Willmott and B.J. Gordon. High jump, #18 (Men). *Report for Scientific Services Project (USATF)*. USA Track & Field, Indianapolis, 98 pp, 1998b.
 39. Dapena, J., A.P. Willmott and B.J. Gordon. High jump, #20 (Men). *Report for Scientific Services Project (USATF)*. USA Track & Field, Indianapolis, 97 pp, 1999b.
 40. Dapena, J., A.P. Willmott and B.J. Gordon. High jump, #28 (Men). *Report for Scientific Services Project (USATF)*. USA Track & Field, Indianapolis, 105 pp, 2004b.
 41. Dapena, J., A.P. Willmott and B.W. Meyer. High jump, #26 (Men). *Report for Scientific Services Project (USATF)*. USA Track & Field, Indianapolis, 117 pp, 2003b.
 42. Dapena, J., A.P. Willmott and B.W. Meyer. High jump, #30 (Men). *Report for Scientific Services Project (USATF)*. USA Track & Field, Indianapolis, 122 pp, 2006b.
 43. Dyatchkov, V.M. The high jump. *Track Technique* 34:1059-1074, 1968.
 44. Krahl, H. and K.P. Knebel. Foot stress during the flop takeoff. *Track Technique* 75:2384-2386, 1979.
 45. Ozolin, N. The high jump takeoff mechanism. *Track Technique* 52:1668-1671, 1973.

ACKNOWLEDGEMENTS

This research project was funded by a grant from USA Track & Field.

APPENDIX 1

TECHNIQUES FOR LOWERING THE CENTER OF MASS IN THE LAST STEPS OF THE RUN-UP

The first steps of a high jump run-up are normal running steps. The c.m. is lowered only near the end, and this is achieved mainly through the combination of a lateral lean toward the center of the curve and the flexion of the knee of the supporting leg (see Figure A2.1 in Appendix 2). At the instant that the takeoff foot is planted on the ground to begin the takeoff phase, the c.m. should be comparatively low, and it should have a large horizontal velocity.

At the instant that the foot lands on the ground in a normal running step, the c.m. of the athlete has a large horizontal velocity and also some downward vertical velocity. But in the last step of a high jump run-up it is important that the downward vertical velocity be minimized, in order not to waste effort braking this downward motion during the takeoff phase. Consequently, the run-up of a high jumper should ideally lead to the following conditions at the start of the takeoff phase: large horizontal velocity, reasonably low c.m., and minimal downward vertical velocity.

Figures A1.1, A1.2 and A1.3 show examples of three techniques used by high jumpers to lower the c.m. In these three figures, the horizontals of the graphs show time (the shaded bars at the bottom indicate ground support phases; the clear bars indicate nonsupport phases, in which both feet are off the ground; $t = 10.00$ s was arbitrarily assigned to the start of the takeoff phase). The verticals of the graphs show the height of the center of mass over the ground, expressed as a percent of the standing height of the athlete.

The graphs correspond to three female high jumpers with similar personal best marks. To facilitate the explanation of these techniques, we will assume that all three athletes took off from the left foot. The c.m. of athlete A, shown in Figure A1.1, was gradually lowered in the late part of the run-up. At about $t = 9.48$ s (two steps before the takeoff phase started), the c.m. was already rather low. Then, as the athlete pushed with the left leg into the next-to-last step, the c.m. went up to start a short projectile path in the air ($t = 9.63$ s). The c.m. reached the peak of the path at $t = 9.66$ s, and then started dropping again. By the time that the right foot was planted, at $t = 9.75$ s, the c.m. was dropping at about -0.9 m/s. Then the support of the right leg reversed the vertical motion of the c.m., first stopping the downward motion at $t = 9.82$ s (at a height somewhat lower than in the previous support phase),

and then pushing the c.m. up again, so that by the time that the right foot lost contact with the ground at $t = 9.93$ s the c.m. was moving upward at 0.4 m/s. Then, during the last nonsupport phase ($t = 9.93 - 10.00$ s), the c.m. made another short projectile path, in which it reached a maximum height and then started dropping again. The c.m. drops with more and more speed with every hundredth of a second that passes by before the takeoff leg is planted. That is why it is recommended that high jumpers plant their takeoff leg very soon, so that they will not be dropping with too much speed at the start of the takeoff phase. The c.m. of this athlete was dropping at -0.3 m/s at the start of the takeoff phase ($v_{ZTD} = -0.3$ m/s).

So in the technique shown by athlete A, the c.m. is already low two steps before the start of the takeoff phase, and it may be lowered still a little bit more in the last step. When the takeoff foot finally makes contact with the ground to start the takeoff phase, the c.m. is more or less low but not dropping very fast (if there is not a long delay in the planting of the takeoff foot; if there were a long delay, the speed of dropping could be large).

Figure A1.2 shows athlete B, with a very different technique. The c.m. was very high two steps before the takeoff phase (after the athlete pushed off into the next-to-last step, the c.m. reached a height of about 59% of the standing height of the athlete). Running with such a high c.m. is much more comfortable than running like athlete A, but it is not possible to start a normal takeoff phase unless the c.m. is lower than that. Therefore, athlete B, consciously or subconsciously, realized that the c.m. had to be lowered. For this, the athlete simply did not stop the drop completely during the period of support over the right foot ($t = 9.84 - 9.95$ s). When the right foot left the ground at $t = 9.95$ s, the athlete was much lower than in the previous step, but the c.m. was not going up at this time: It was still dropping. The speed of dropping became still larger in the following nonsupport phase. Even though the athlete planted the takeoff foot very soon, by then the c.m. was dropping at a very large speed (-0.7 m/s), and this is not good for the takeoff phase of the jump.

The advantage of the technique used by jumper B is that it made it very easy for the athlete to maintain (and even increase) a fast run-up speed in the last steps. Athlete A was not able to maintain speed quite as well, because it is difficult to run fast over a deeply flexed support leg. The disadvantage of the technique of athlete B was that the c.m. was dropping with a large speed at the start of the takeoff phase, while the c.m. of athlete A was moving more flat.

The ideal would be to lower the hips early, as

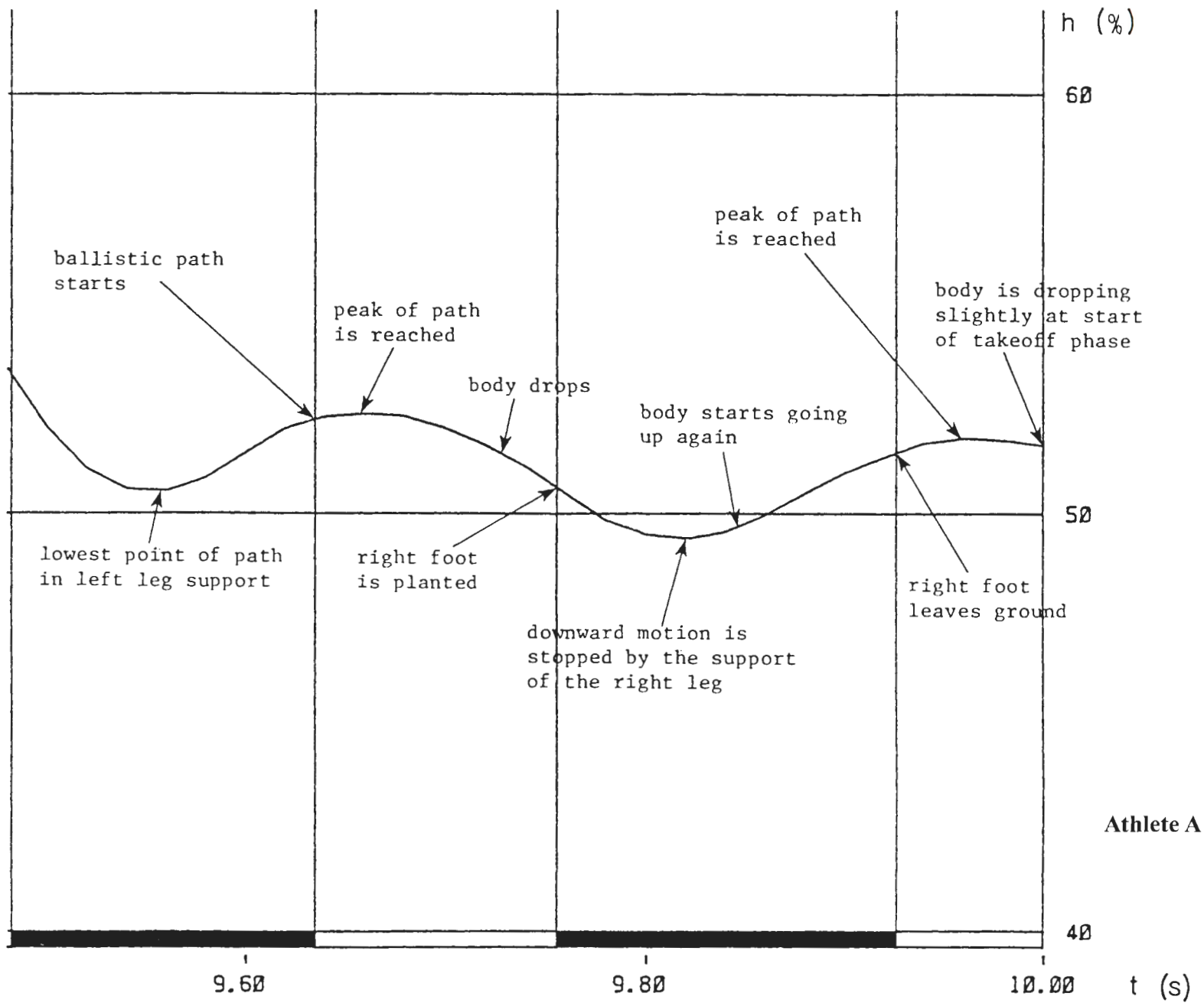

Figure A1-1

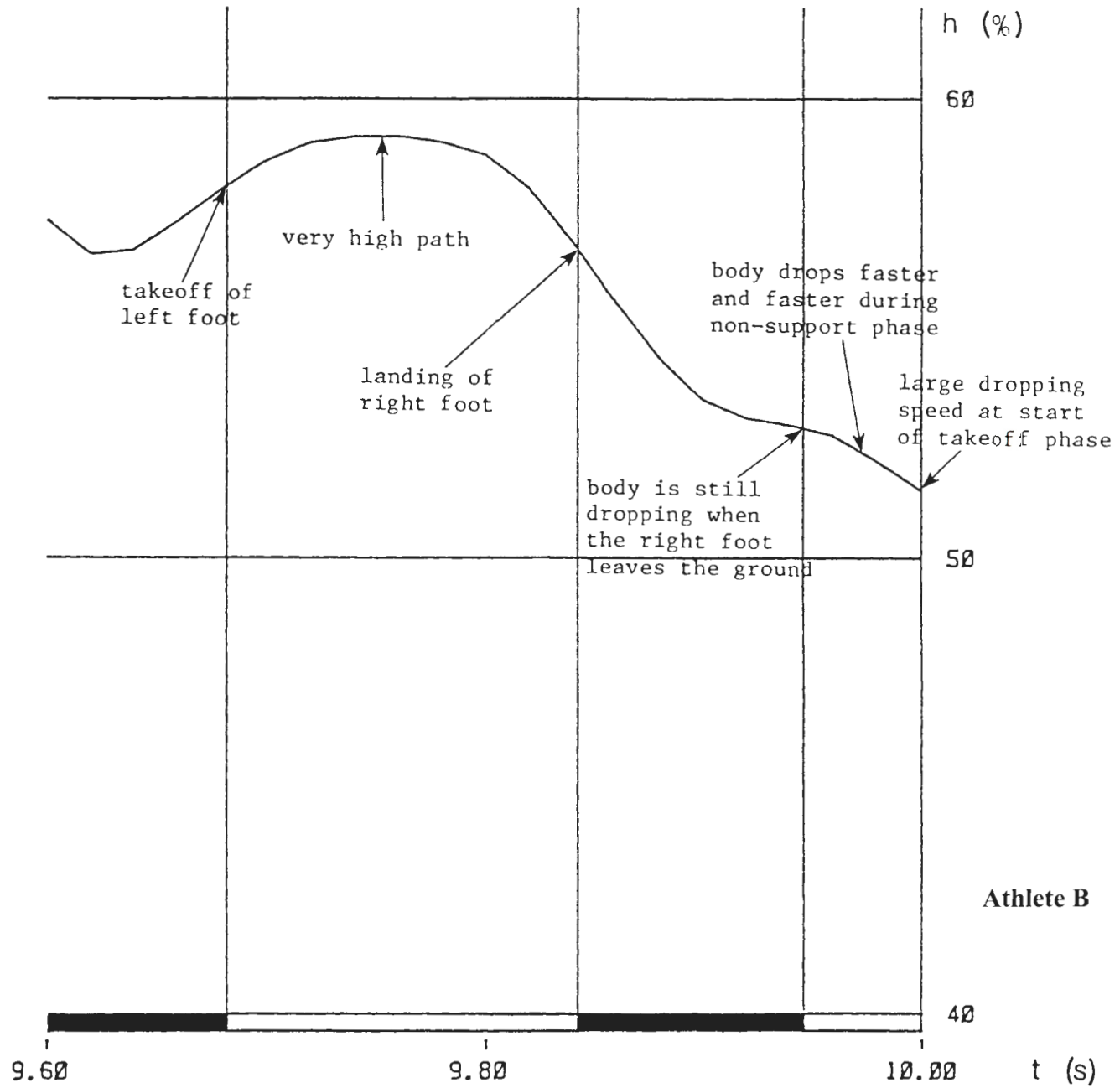

Figure A1-2

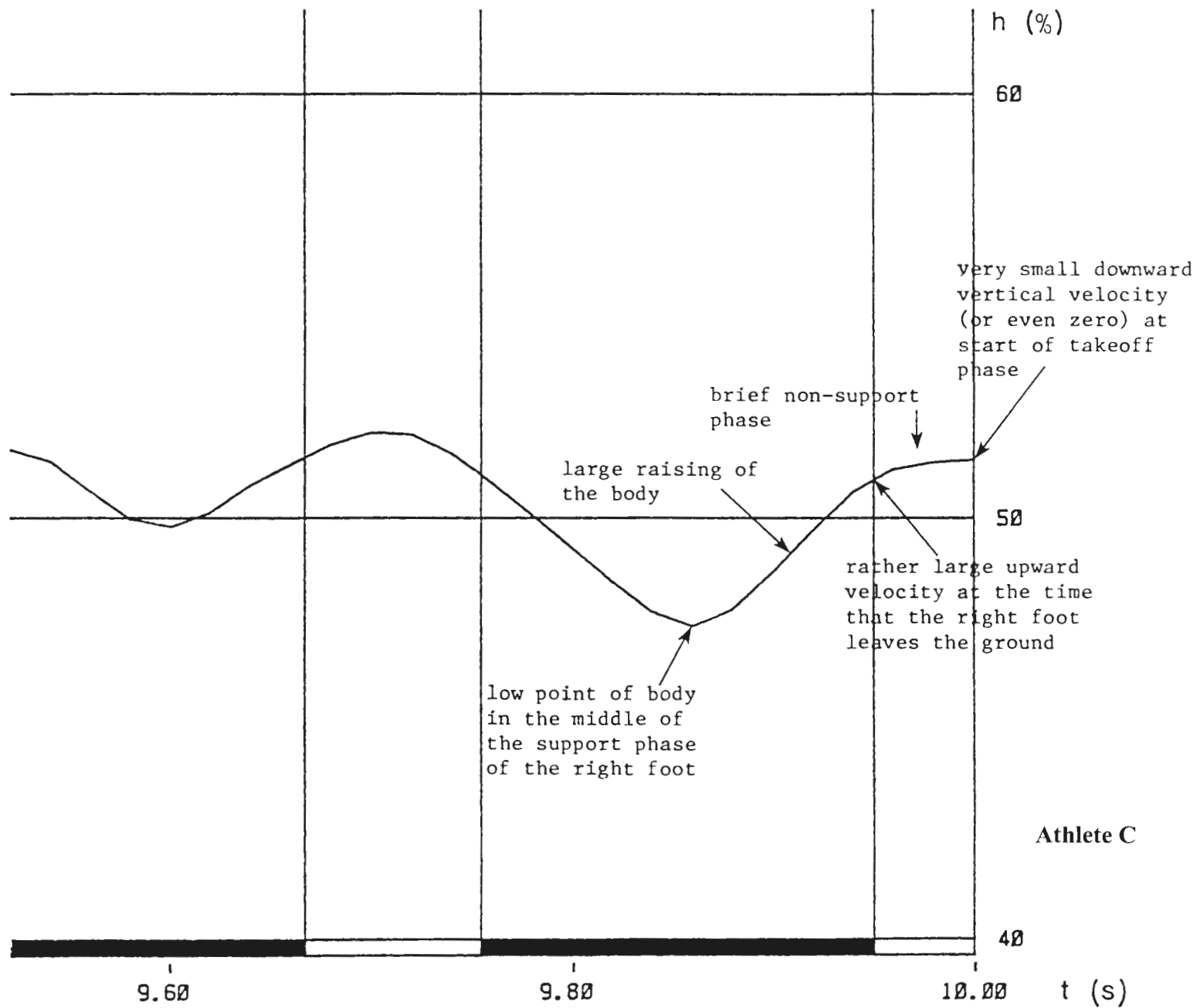

Figure A1-3

athlete A did, but avoiding any loss of horizontal speed. For this, athlete A would need special drills and exercises (see Appendix 2); athlete B would need to start lowering the c.m. earlier, two or three steps before takeoff, and this athlete would also need to do the drills and exercises; otherwise, she would brake the horizontal speed of the run-up when she lowered the hips.

Figure A1.3 shows an interesting technique by a third athlete (athlete C). In the middle of the last support phase of the approach run ($t = 9.85$ s), the c.m. of athlete C was lower than those of athletes A and B, but in the second half of this support phase the athlete lifted the c.m. considerably, and by the end of it ($t = 9.95$ s) the c.m. had a rather large upward vertical velocity (0.5 m/s). The airborne phase that followed was very brief. By the beginning of the takeoff phase ($t=10.00$ s), the c.m. was at about the same height as those of the other two jumpers, but it was not dropping at all: The vertical velocity of athlete C at the start of the takeoff phase was 0.0 m/s.

At this point, it is not possible to decide whether athlete C would have been better off maintaining a lower path of the c.m. in the last step, at the expense of a moderate negative vertical velocity at the start of the takeoff phase (like athlete A), or with the present technique, in which she sacrificed part of the previous lowering of the c.m. in order to avoid having any negative vertical velocity at the start of the takeoff phase.

In sum, based on the information presently available, the techniques used by athletes A and C to lower the c.m. appear to be equally good, but the technique used by athlete B seems to be worse, because it leads to a very large downward velocity at the start of the takeoff phase.

APPENDIX 2

EXERCISES TO HELP THE LOWERING OF THE CENTER OF MASS IN THE LAST STEPS OF THE RUN-UP

Many high jumpers have difficulties in the last steps of the approach run: They are unable to run fast while keeping their hips low. This is a typical problem in high jumping technique. It takes some

Figure A2.1

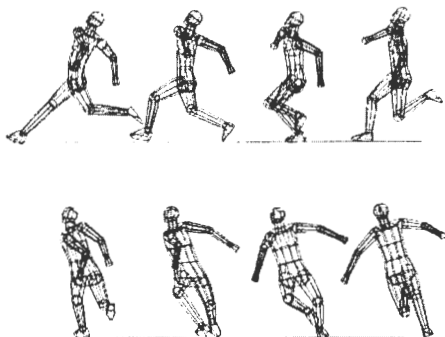

effort to correct this problem, but the improvements that the correction produces are definitely worth the effort.

The greatest difficulty is to be able to pass over the deeply-flexed non-takeoff leg in the next-to-last step, and have the non-takeoff leg support the whole body with no sign of collapse or of braking. This is demonstrated very well by the athlete in Figure A2.1.

Figure A2.2 shows an exercise with weights that can help the high jumper to acquire the necessary support strength in the non-takeoff leg. (This exercise was devised by Arturo Oliver.) The start of the exercise is in a static position (a). Then, the

Figure A2.2

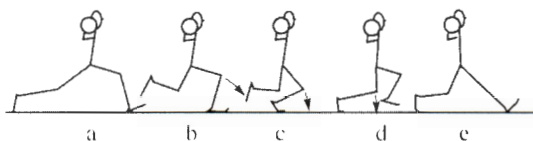

athlete pushes off gently with the back leg (the takeoff leg), to place the weight of the body over the non-takeoff leg. The body then slowly passes over the non-takeoff leg (positions b-d), and finally, at the last instant, the takeoff leg is placed ahead on the

ground, to stop the forward motion. After stopping momentarily in position e, the takeoff leg makes a slight push forward on the ground, and by reaction the athlete goes backward again to position a. The exercise is repeated over and over until the non-takeoff leg gets tired.

Important points to consider: The whole motion should be very slow. The knee of the non-takeoff leg should be kept very flexed at about 90° throughout the whole exercise. From positions a to d the athlete should feel as if he/she were going to kneel with the non-takeoff leg, with the hip well forward. The most difficult point of the exercise is at position d. Between positions d and e, the non-takeoff leg should not be extended significantly. The idea is to thrust the hips forward (**but without extending the knee of the non-takeoff leg**) at the last instant, just before losing balance forward. Immediately afterward, the foot of the takeoff leg is planted ahead of the body to stop the forward motion (position e). It would possibly be desirable, from the point of view of motor learning, to have the trunk acquire between positions d and e some backward lean, similar to the one that occurs in actual jumping (see Figure A2.1). However, this is difficult to do with the weights, and it is not crucial for the exercise. The exercise should first be done with only a 10 Kg bar without weights. Then, when the athlete has learned the exercise, very light weights can be added. As the athlete gets stronger, the weights should gradually be increased.

Figure A2.3

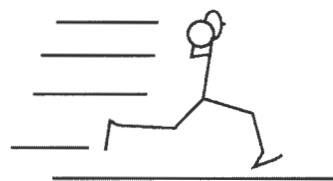

A second exercise is shown in Figure A2.3. It was also devised by Arturo Oliver, and it consists of 30 to 50-meter runs at about 50% of maximum speed, with the hips held low (as low as in the last steps of a high jump approach run), and carrying a 20-25 Kg barbell on the shoulders (IMPORTANT: Wrap a towel around the bar). The main idea is to force the athlete to run with low, flat, non-bouncy steps; if the athlete makes bouncy steps, the barbell will bounce on the shoulders, the athlete will notice it, and make adjustments in the running to prevent the excessive bouncing. **Make sure that no one is in your way when you do this exercise!**

When the athlete is able to do these exercises

fairly well (say, after one month of practice), it will be time to start introducing the new motions into actual jumping. It may be good to start with low-intensity "pop-ups" using a short run-up (four or six steps) at a slow speed. The emphasis should be on lowering the hips in the last two or three steps without losing any speed. Then, the length and speed of the run-up for these pop-ups should be increased gradually, and after a few days (or weeks --it depends on how quickly the athlete assimilates the new movements), the athlete will be practicing with a full high jump run-up and a bar. When jumping using the full speed of a normal high jump, it will be more difficult to avoid braking while the athlete passes over the deeply-flexed non-takeoff leg in the last support of the run-up. **To avoid braking, the athlete will have to concentrate intensely on trying to pull backward with the non-takeoff foot when it lands on the ground.**

APPENDIX 3

PRODUCTION OF LATERAL SOMERSAULTING ANGULAR MOMENTUM

The main text of this report explains that high jumpers need a combination of forward somersaulting angular momentum (H_F) and lateral somersaulting angular momentum (H_L) to be able to achieve a normal rotation over the bar (see “Angular momentum”). In this section of the report we will deal in greater depth with H_L and how it is produced.

The three images in the upper left part of Figure A3.1 show a back view sequence of the takeoff phase of a high jumper and the force that the athlete makes on the ground during the takeoff phase (actually, this force will change from one part of the takeoff phase to another, but for simplicity the average force has been drawn here in all three images). The three images in the upper right part of Figure A3.1 show the same sequence, but the force shown here is the equal and opposite force that the ground makes on the athlete in reaction to the force that the athlete makes on the ground.

The athlete shown in the six images in the top row of Figure A3.1 had a standard technique: At the start of the takeoff phase, the athlete was leaning toward the center of the curve (in this case, to the left). The takeoff foot was planted pretty much directly ahead of the c.m., and therefore in this back view the foot appears almost directly underneath the c.m. (the small circle inside the body). During the takeoff phase, the athlete exerted a force on the ground, and by reaction the ground exerted a force on the athlete. The force exerted by the ground on the athlete made the athlete start rotating clockwise in this back view. By the end of the takeoff phase, the athlete was rotating clockwise, and the body had reached a pretty much vertical position.

A key element for the production of the clockwise rotation of the athlete is the force exerted by the ground on the athlete. This force must pass clearly to the left of the c.m. If the force passes too close to the c.m., there will be very little rotation, and if it passes directly through the c.m. there will be no rotation at all. So the force must be pointing up and slightly to the left, and this is what the three images in the upper right part of Figure A3.1 show. To obtain these forces, the athlete must push on the ground down and slightly to the right, as the three images in the upper left part of Figure A3.1 show. Most athletes are not aware that during the takeoff phase they push with their takeoff foot slightly away from the center of the curve, but they do.

As the force exerted by the ground on the athlete usually points upward and to the left in this view

from the back, it causes the path of the c.m. of the athlete to deviate a little bit to the left during the takeoff phase, making angle p_0 be generally somewhat smaller than angle p_1 (see Figure 2 and Table 2 in the main text of the report). This is interesting for us, because it implies that by comparing the sizes of these two angles we can check whether an athlete pushed away from the center of the curve during the takeoff phase or not.

The technique described above is used by most athletes. However, some jumpers push directly down, or even toward the center of the curve, during the takeoff phase (in these jumpers, angle p_0 is equal to p_1 or larger than p_1 , respectively). This leads to problems. If the athlete placed the takeoff foot directly ahead of the c.m., the athlete would not get any lateral somersaulting rotation the result could even be a counterclockwise lateral somersaulting rotation. Therefore, some of these athletes place the takeoff foot ahead of the c.m. but slightly to the left (see athlete 2, in the middle row of Figure A3.1). This allows these athletes to obtain some lateral somersaulting angular momentum, but not much, because during the takeoff phase the force exerted by the ground on the athlete passes only slightly to the left of the c.m.

Other athletes that push toward the center of the curve during the takeoff phase want more angular momentum than that, and therefore they place the takeoff foot on the ground ahead of the c.m. and very markedly to the left (see athlete 3, in the bottom row of Figure A3.1). In these athletes the force exerted by the ground on the athlete passes clearly to the left of the c.m., and therefore they get a good amount of lateral somersaulting angular momentum. However, they pay a price for this: Because the foot is placed so far to the left, the c.m. is always to the right of the foot in a view from the back, and therefore the body has a marked lean toward the right by the end of the takeoff phase.

Most high jumpers push away from the center of the curve during the takeoff phase without needing to think about it. Therefore, it generally is not necessary to tell athletes that they have to do this. However, a jumper with the problems demonstrated by athletes 2 and 3 of Figure A3.1 will need to be told to push with the takeoff leg away from the center of the curve, and the coach should make up drills to help to teach the athlete how to do this if the problem occurs.

Figure A3-1

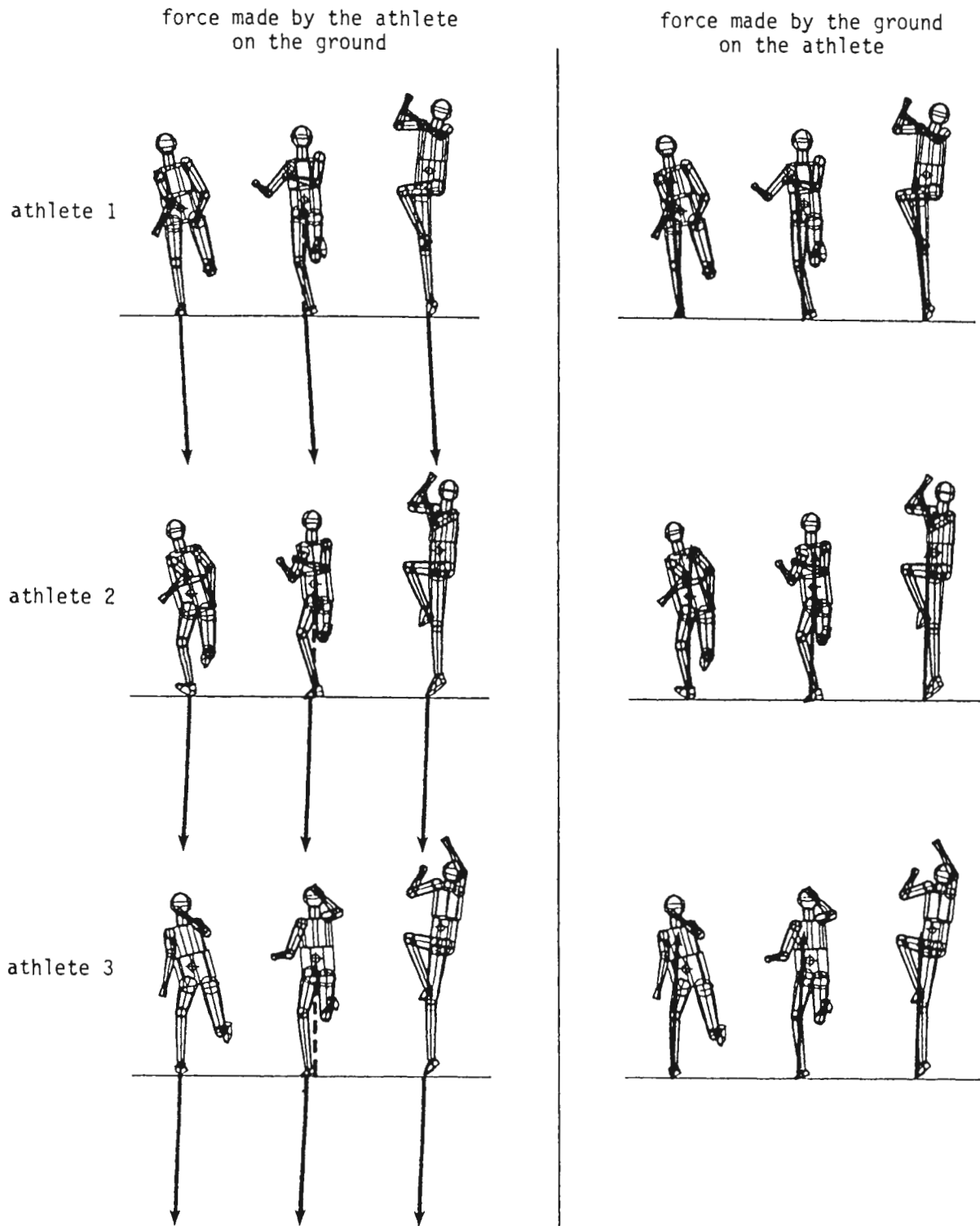

APPENDIX 4

DRAWING THE PATH OF A HIGH JUMP RUN-UP

The curved run-up used in the Fosbury-flop style of high jumping makes the athlete lean toward the center of the curve. This helps the jumper to lower the c.m. in the last steps of the run-up. It also allows the athlete to rotate during the takeoff phase from an initial position in which the body is tilted toward the center of the curve to a final position in which the body is essentially vertical; therefore, it allows the athlete to generate rotation (lateral somersaulting angular momentum) without having to lean excessively toward the bar at the end of the takeoff.

A curved run-up has clear benefits over a straight one, and therefore all high jumpers should use a curved run-up. However, a curved run-up is also more complex. Therefore, it is more difficult to learn, and requires more attention from the athlete and the coach.

The curved run-up can also be a source of inconsistency: There are many different possible paths that the jumper can follow between the start of the run-up and the takeoff point. If the athlete does not always follow the same path, the distance between the takeoff point and the bar will vary from one jump to another. This inconsistency will make it difficult for the athlete to reach the peak of the jump directly over the bar.

To make it easier for a high jumper to follow a given run-up path consistently, it can be useful to mark the desired path on the ground for practice sessions (Dapena, 1995a; Dapena *et al.*, 1997a). But before drawing the run-up path, it will first be necessary to choose values for the two main factors that determine the path: (a) the final direction of the run-up and (b) the radius of curvature.

Deciding the final direction of the run-up path (angle p_1)

The final direction of the run-up can be defined as the angle between the bar and the direction of motion of the c.m. in the last airborne phase of the run-up immediately before the takeoff foot is planted on the ground. This angle is called p_1 in this report, and its values are given in Table 2. (The angle of the final run-up direction should not be confused with the angle between the bar and the line joining the last two footprints. This latter angle is called t_1 , and it is generally 10-15 degrees smaller than the angle of the final run-up direction, p_1 .) Jumpers analyzed in this report should use the value of p_1 given in Table 2 (or in some cases a different value proposed for the

athlete in the Specific Recommendations section). Jumpers not included in this report should first assume that their ideal p_1 angle is 40° . Then, if the run-up curve drawn based on that angle does not feel comfortable, they should experiment with other p_1 values until they find an angle that feels good. For most athletes the optimum value of p_1 will be somewhere between 35° and 45° .

Deciding the radius of curvature of the run-up path (distance r)

The run-up curve needs to have an optimum radius of curvature. If the radius is too small, the curve will be too tight, and the athlete will have difficulty running; if the radius is too large, the curve will be too straight, and the athlete will not lean enough toward the center of the curve. The optimum radius will depend on the speed of the jumper: The faster the run-up, the longer the radius should be. We can make a rough estimate of the optimum value of the radius of curvature for an individual high jumper using the equation $r = v^2 / 6.8$ (men) or $r = v^2 / 4.8$ (women), where r is the approximate value of the radius of curvature (in meters), and v is the final speed of the run-up (in meters/second). Jumpers who know their final run-up speed (such as the jumpers analyzed in this report) can make a rough initial estimate for their optimum radius of curvature by substituting into the appropriate equation their own v_{HI} value from Table 3 (or a different value of v_{HI} proposed for that athlete in the Specific Recommendations section). For jumpers not analyzed in this report, it is more difficult to select a good initial estimate for the radius of curvature, but the following rough guidelines can be followed for olympic-level high jumpers: 6.5-11 m for men; 7.5-13 m for women. In all cases (even for the jumpers analyzed in this report), the *optimum* value of the radius of curvature for each individual athlete will ultimately have to be found through fine-tuning, using trial and error.

Actual drawing of the run-up

Materials needed: a measuring tape (at least 15 meters long), a piece of chalk, and white adhesive tape.

Tell the athlete to make a few jumps at a challenging height, using his/her present run-up. Using adhesive tape, make a cross on the ground to mark the position of the takeoff point (point A in Figure A4.1).

Put one end of the measuring tape at point A, and measure a distance j parallel to the bar. The value of j depends on the final direction desired for the run-up (p_1):

p_1	j
25°	1.75 m
30°	2.70 m
35°	3.65 m
40°	4.65 m
45°	5.75 m
50°	7.00 m

(General guidelines for the optimum value of p_1 were given previously in this Appendix. If you want to try a p_1 angle intermediate between the ones given in this table, you should use a value of j intermediate between the ones given in the table.)

Mark the new point (B) with chalk. Put one end of the tape at point B, and measure a distance $k = 10$ meters in the direction perpendicular to the bar. Mark the new point (C) with chalk. The line joining point A and point C indicates the direction of the center of the curve relative to the takeoff point.

Figure A4.1

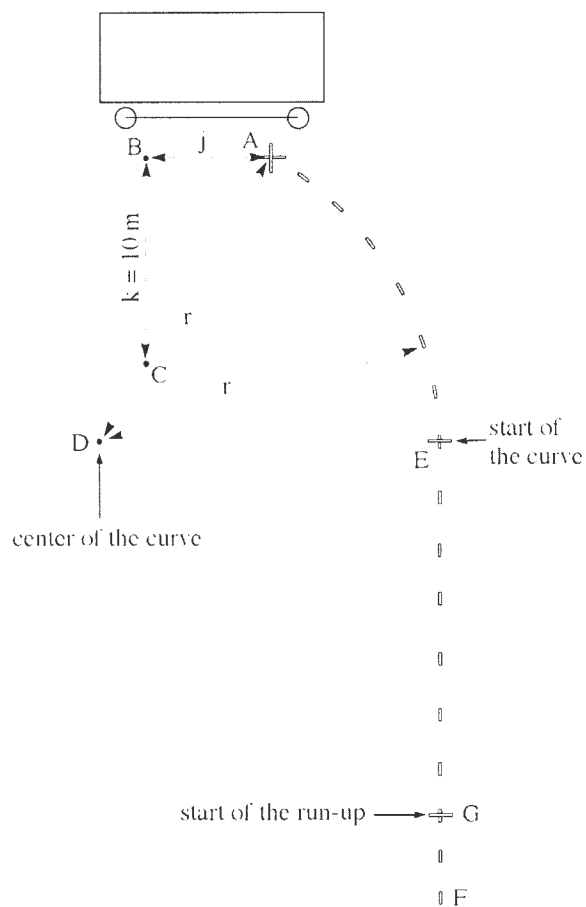

To find the center of the curve (point D), put one end of the tape at point A, and make the tape pass over point C. The center of the curve will be aligned with points A and C, and it will be at a distance r from point A. (General guidelines for the optimum value of r were given previously in this Appendix.) Mark point D with chalk.

With center in point D and radius r , draw an arc from point A to point E. (Point E has to be at the same distance from the plane of the bar and the standards as point D.) The arc from A to E is the run-up curve. Mark it with strips of adhesive tape. Put a transverse piece of tape at point E to mark the start of the curve.

Starting at point E, draw a straight line perpendicular to the bar (E-F), and mark it with strips of adhesive tape. Set the bar at a challenging height, and have the jumper take a few jumps. By trial and error, find the optimum position for the start of the run-up (point G), and mark it with a transverse piece of adhesive tape.

The run-up is now ready. The set-up just described can be left in place for training, and it will contribute to drill into the athlete the pattern that the run-up should follow.

Things to remember:

- Point E indicates the place where the curve should start, but the athlete does not necessarily have to step on this point.
- Some jumpers may find it difficult to follow exactly the path marked by the adhesive tape in the transition from the straight to the curved part of the run-up. This should not be a problem: It is acceptable to deviate somewhat from the path marked by the adhesive tape in the area around point E, as long as the athlete deviates consistently in the same way in every jump.
- It is important to follow the tape very precisely in the middle and final parts of the curve.

The set-up described above can be left in place for training. However, one or two marks will have to suffice for competitions. Distances a , b , c and d should be measured in the training set-up (see Figure A4.2). In the competition, distance a will be used to reconstruct the position of point H. Distances b and c will then be used to reconstruct the triangle formed by the standard and points G and H. This will allow the athlete to locate the start of the run-up (point G). Distance d can be used to find the position of point E if the rules of the competition allow for a mark to be placed at that point.

Figure A4.2

